

Foreword

E09200108351

Thank you for selecting a MITSUBISHI MOTORS product as your new vehicle.

This owner's manual will add to your understanding and full enjoyment of the many fine features of this vehicle.

It contains information prepared to acquaint you with the proper way to operate and maintain your vehicle for the utmost in driving pleasure.

MITSUBISHI MOTORS CORPORATION reserves the right to make changes in design and specifications and/or to make additions to or improvements in this product without obligation to install them on products previously manufactured.

It is an absolute requirement for the driver to strictly observe all laws and regulations concerning vehicles.

This owner's manual has been written in compliance with such laws and regulations, but some of the contents may become contradictory with later amendment of the laws and regulations.

Please leave this owner's manual in this vehicle at time of resale. The next owner will appreciate having access to the information contained in this owner's manual.



Throughout this owner's manual the words **WARNING** and **CAUTION** appear. These serve as reminders to be especially careful. Failure to follow instructions could result in personal injury or damage to your vehicle.

WARNING

Indicates a strong possibility of severe personal injury or death if instructions are not followed.

CAUTION

Means hazards or unsafe practices that could cause minor personal injury or damage to your vehicle.

You will see another important symbol:

NOTE

Gives helpful information.

***: Indicates optional equipment.**

It may differ according to the sales classification; refer to the sales catalogue.

Abbreviations used in this owner's manual:

M/T: Manual Transmission

A/T: Automatic Transmission

CVT: Continuously Variable Transmission

The symbol used on the vehicles:

: See owner's manual

This vehicle is manufactured by PT. Mitsubishi Motors Krama Yudha Indonesia in Indonesia under license from Mitsubishi Motors Corporation.

©2019 Mitsubishi Motors Corporation

Table of contents

Overview/Quick guide	1
General information	2
Locking and unlocking	3
Seat and seat belts	4
Instruments and controls	5
Starting and driving	6
For pleasant driving	7
For emergencies	8
Vehicle care	9
Maintenance	10
Specifications	11
Alphabetical index	12

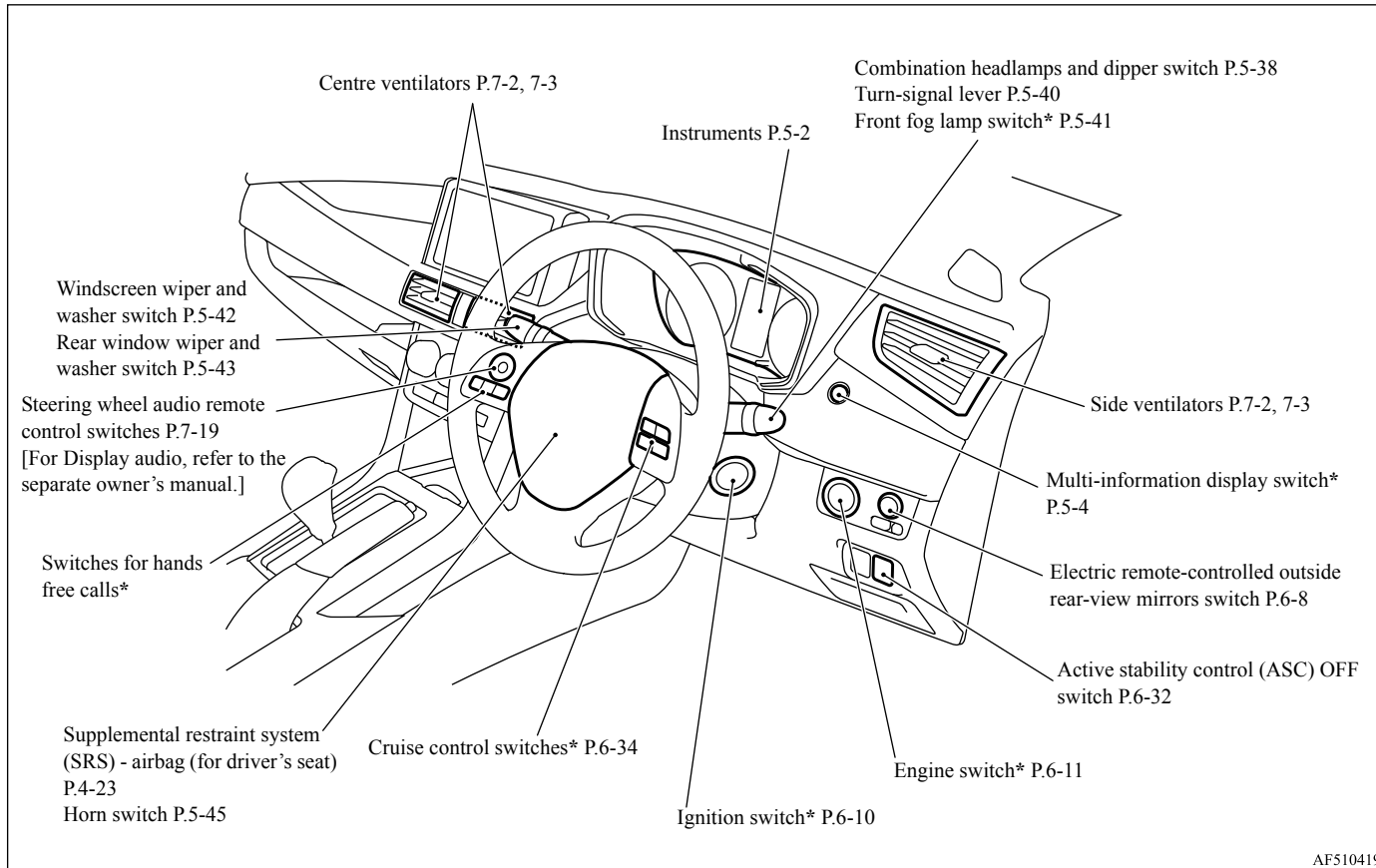

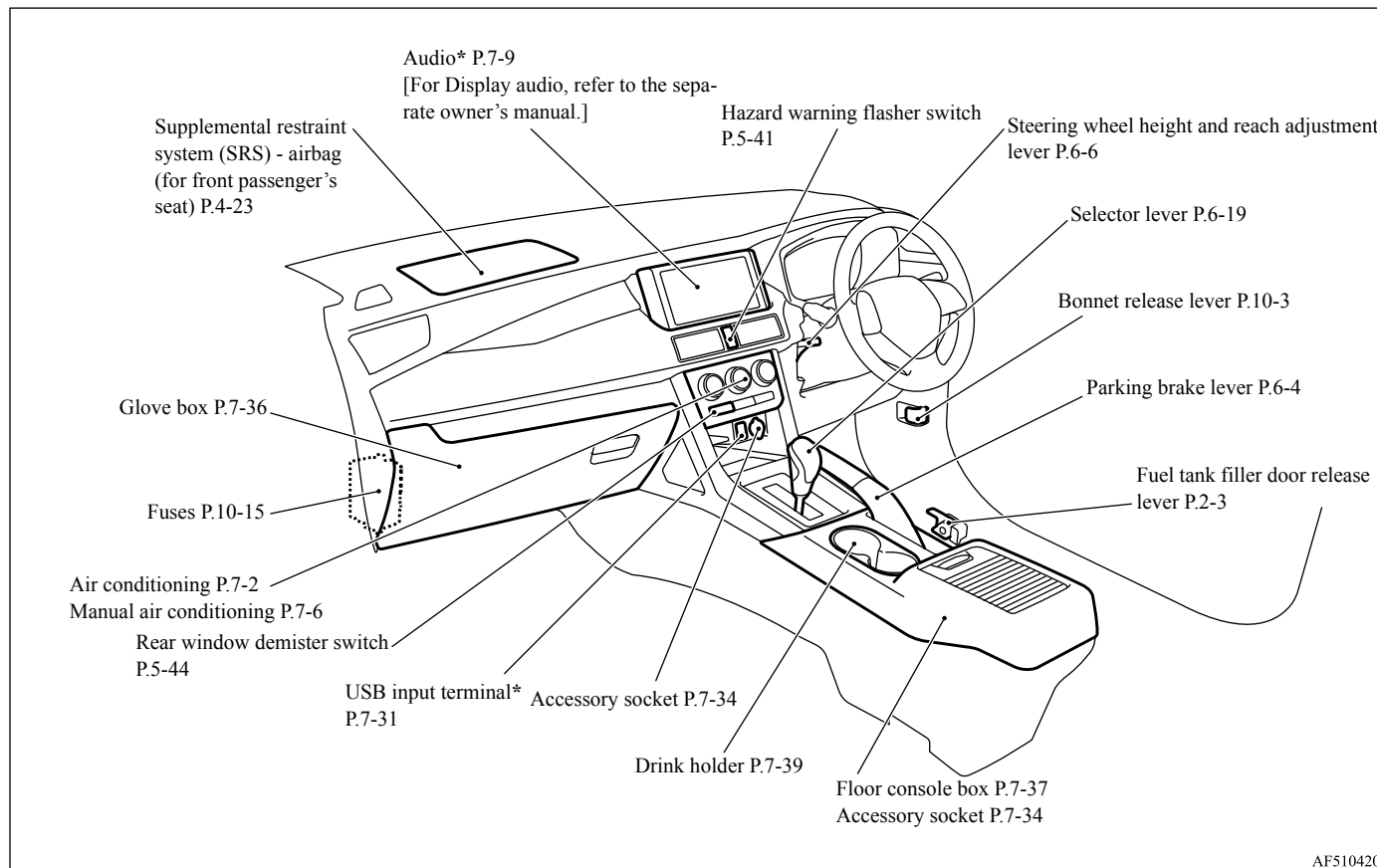

1 Interior

E08500202558

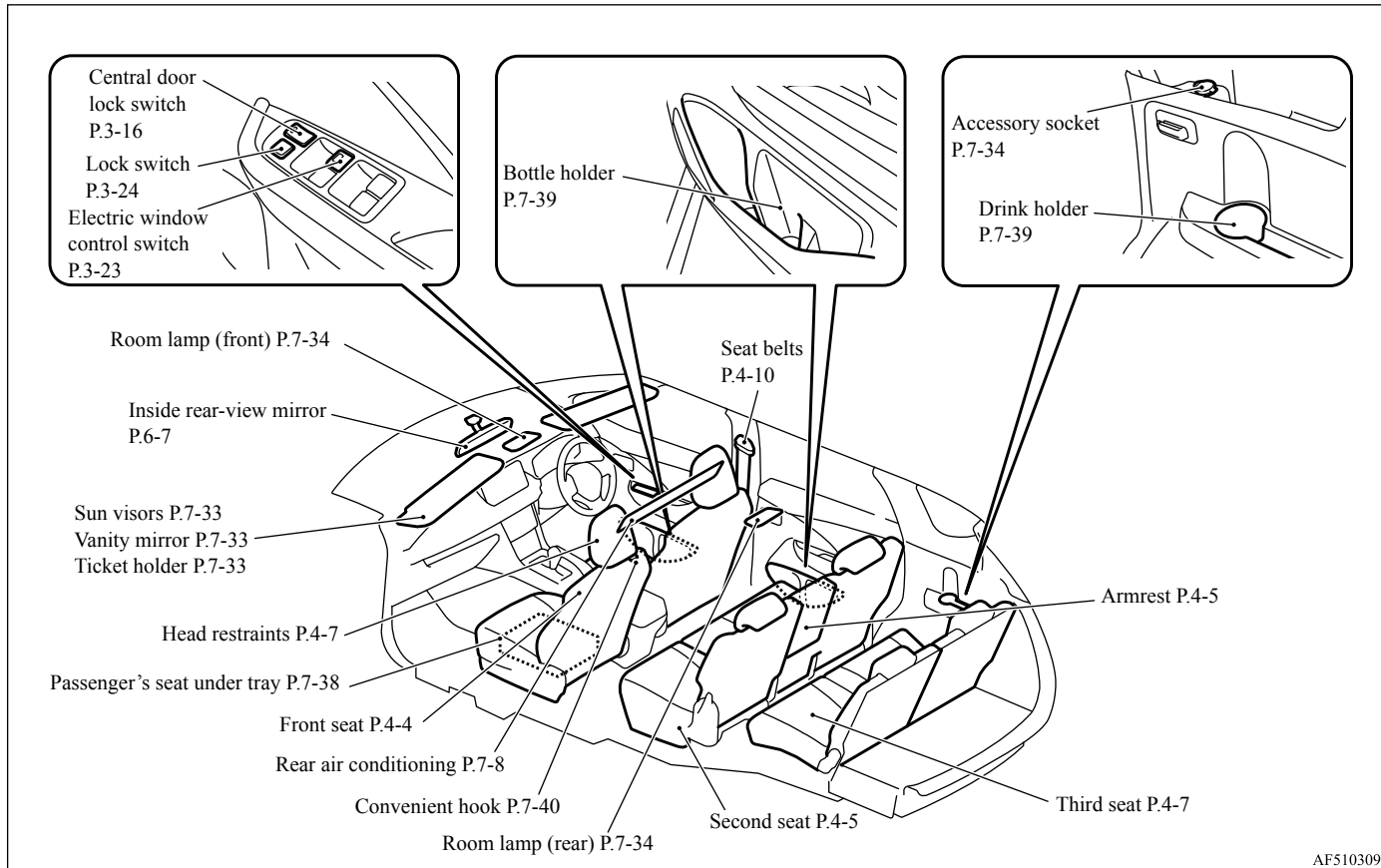

Luggage area

1

E08500301666

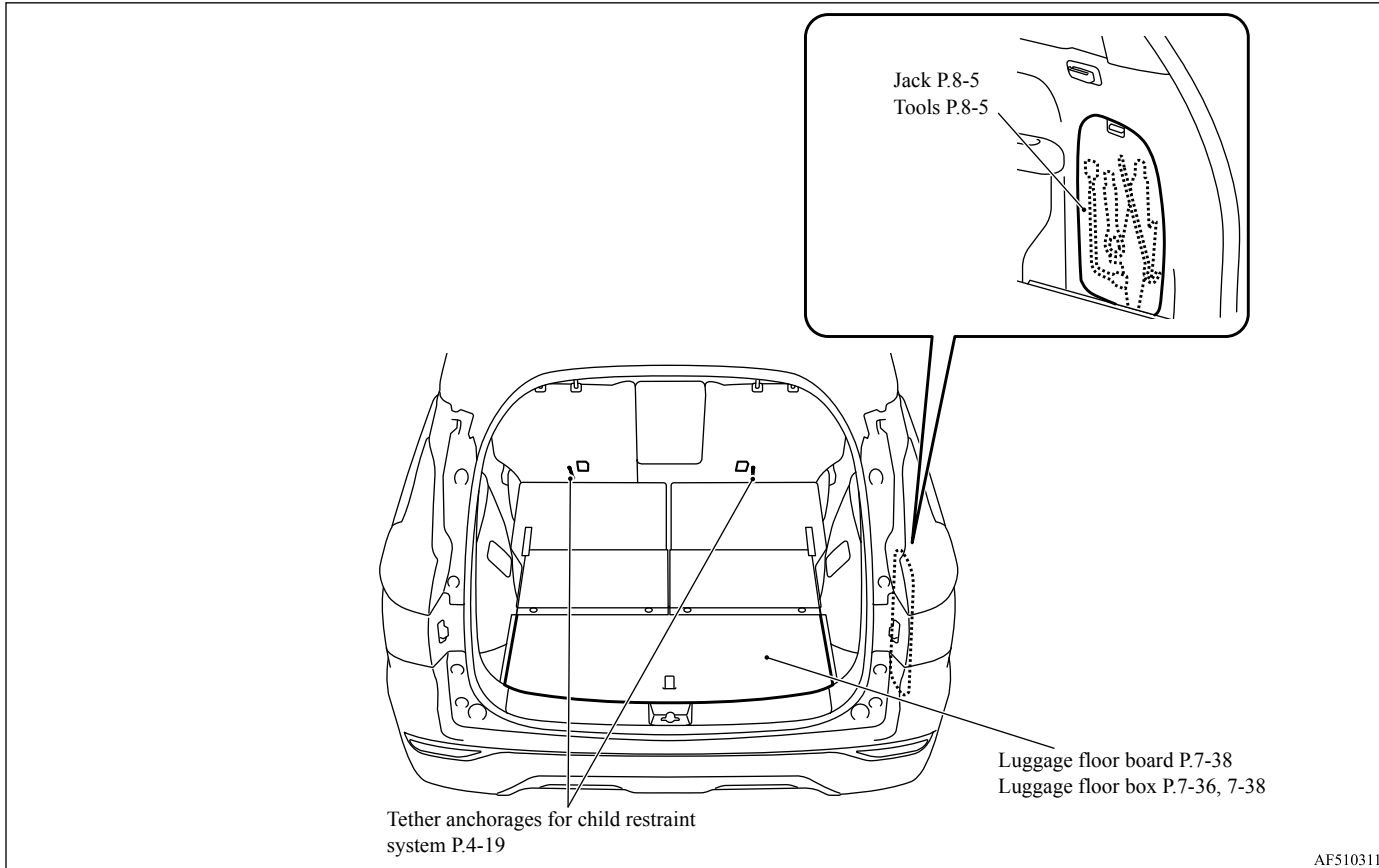

AF5103114

1 Exterior - front

E08500403704

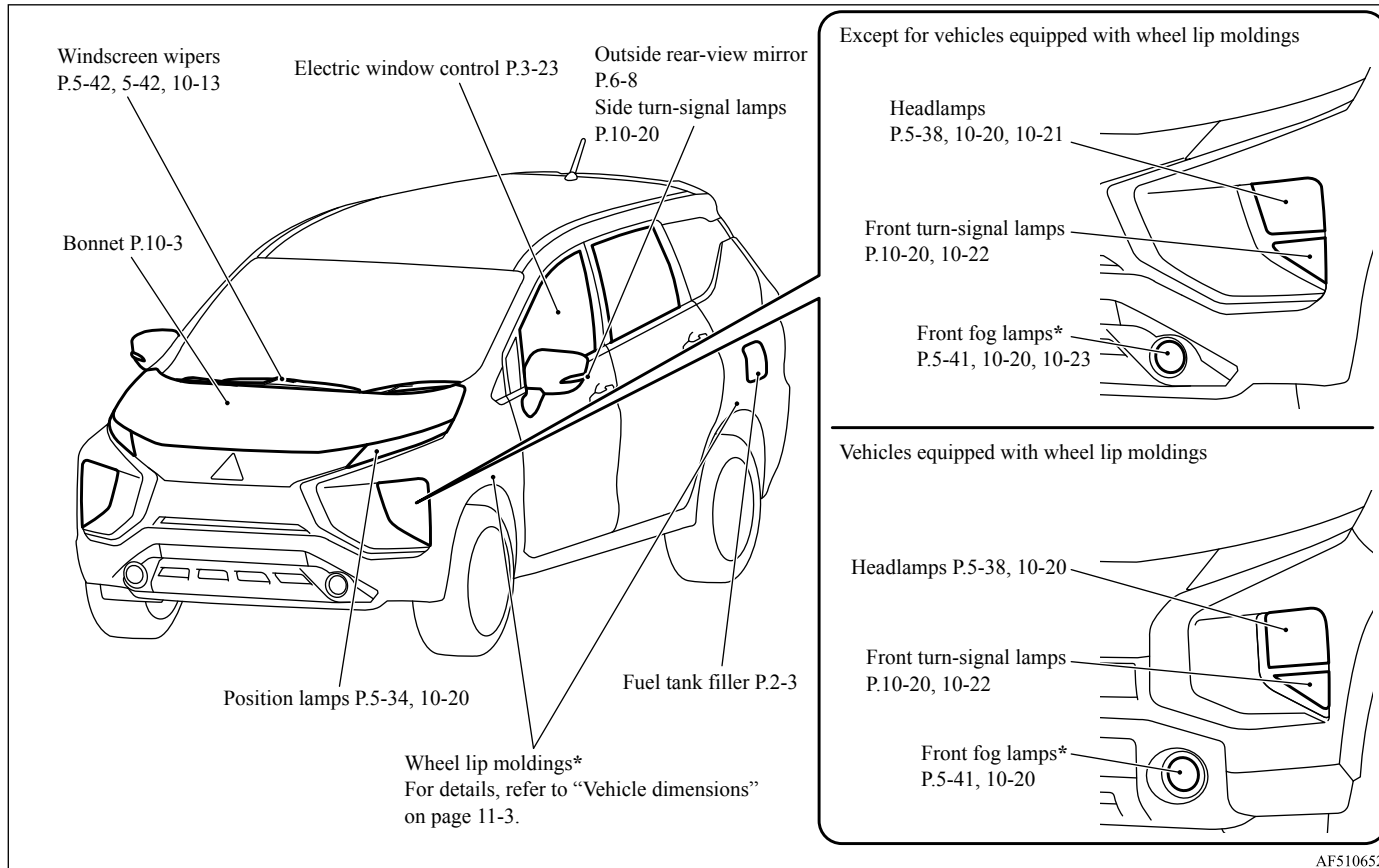

AF5106522

Exterior - rear

E08500403717

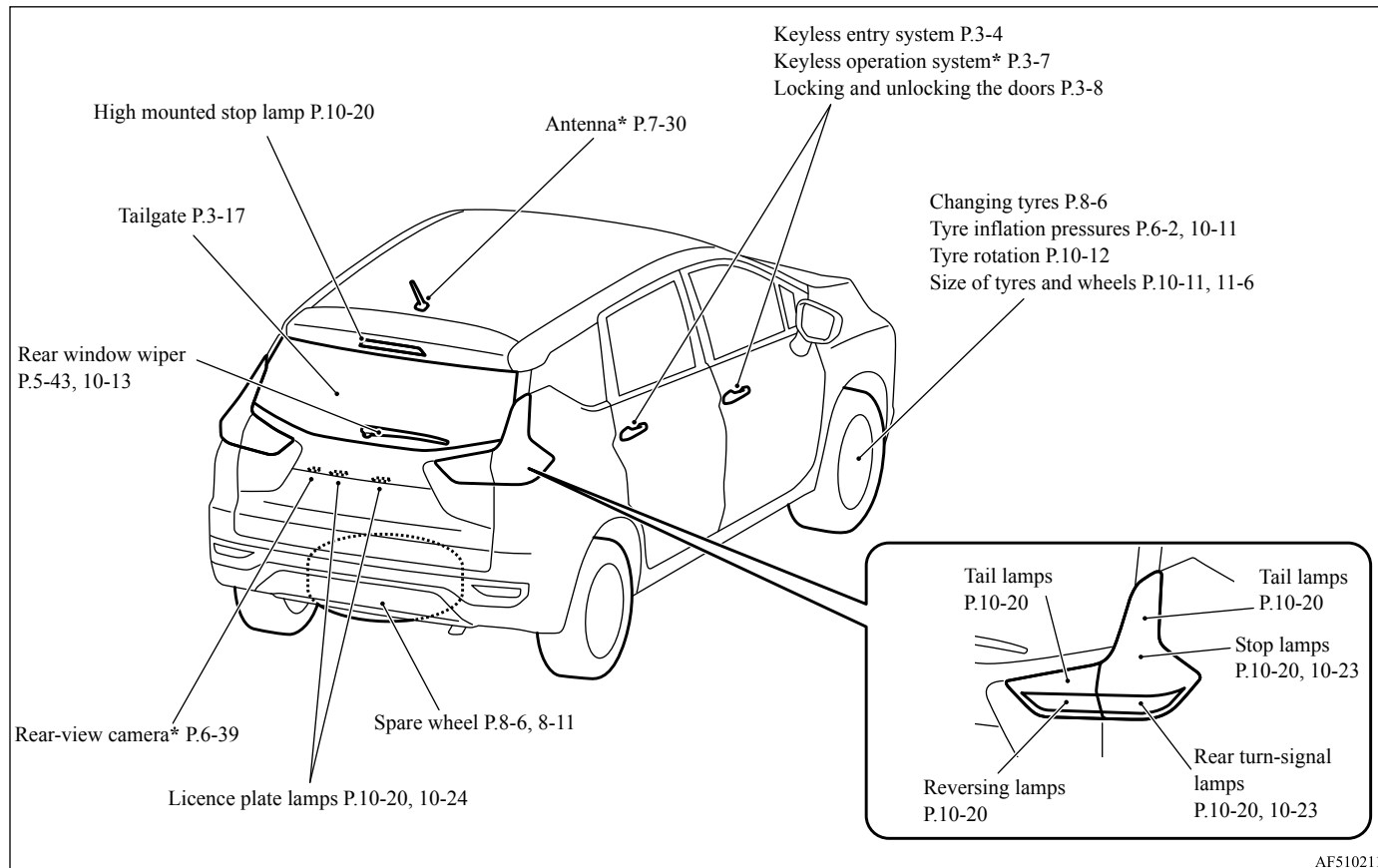

Quick guide

1

Quick guide

E08500501059

Lock and unlock the doors and tailgate

E08500602233

Keyless entry system

Press the key switch, and all doors and the tailgate will be locked or unlocked as desired. It is also possible to operate the outside rear-view mirrors.

The key switch will operate within approximately 4 m from the vehicle.

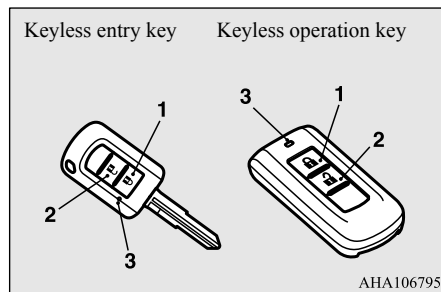

- 1- LOCK switch
- 2- UNLOCK switch
- 3- Indicator lamp

Refer to “Keyless entry system” on page 3-4.

The outside rear-view mirrors can be retracted and extended automatically if you press the LOCK switch (1) or UNLOCK switch (2).

Refer to “Operation of the outside rear-view mirrors” on page 3-5.

Keyless operation system*

When you are carrying the keyless operation key, if you press the driver’s or front passenger’s door lock/unlock switch (A), or the tailgate lock/unlock switch (B) within the operating range, the doors and the tailgate are locked.

The operating range is approximately 70 cm from the driver’s or front passenger’s door lock/unlock switch, and tailgate lock/unlock switch.

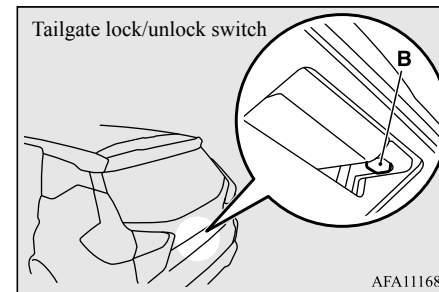
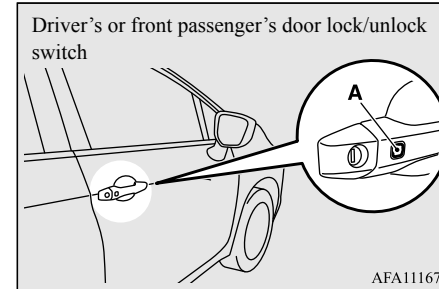

Refer to “Keyless operation system” on page 3-7.

Around the driver's seat

E08500802378

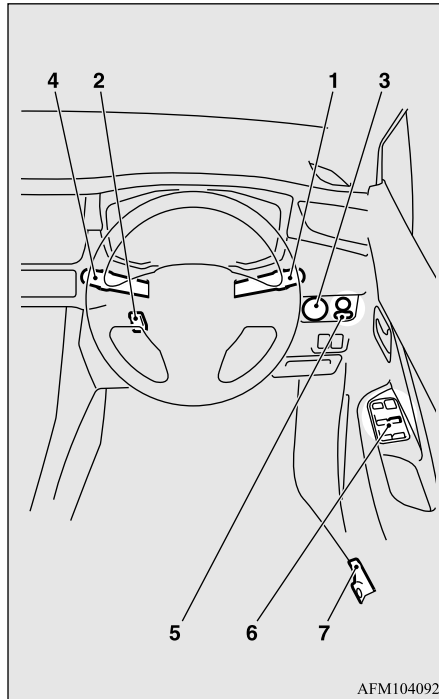

AFM104092

1-Combination headlamps

Rotate the switch to turn on the lamps.

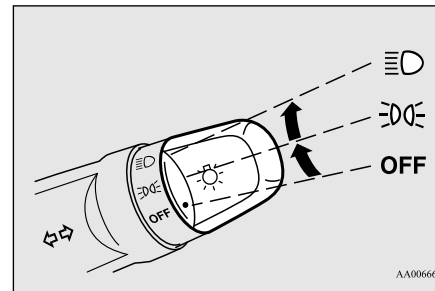

AA006688

OFF	All lamps off
☰☪	Position, tail, licence plate and instrument panel lamps on
☰☪	Headlamps and other lamps on

Refer “Combination headlamps and dipper switch” on page 5-38.

1-Turn-signal lever

The turn-signal lamps flash when the lever is operated (with the ignition switch or the operation mode is in ON).

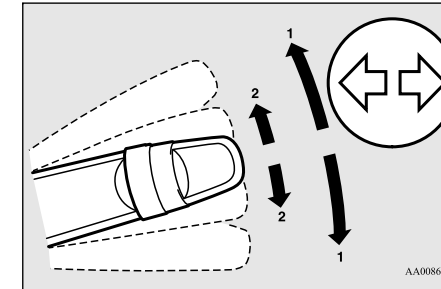

AA0086512

- 1- Turn-signals
- 2- Lane-change signals

Refer “Turn-signal lever” on page 5-40.

1

1 2-Steering wheel height and reach adjustment

1. Release the lever while holding the steering wheel up.
2. Adjust the steering wheel to the desired position.
3. Securely lock the steering wheel by pulling the lever fully upward.

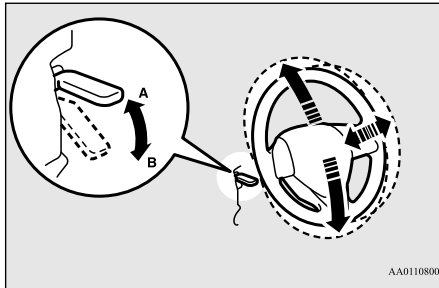

- A- Locked
- B- Release

Refer “Steering wheel height and reach adjustment” on page 6-6.

3-Engine switch*

If you are carrying the keyless operation key, you can start the engine. If you press the engine switch without depressing the brake pedal, you can change the operation mode in the order of OFF, ACC, ON, OFF.

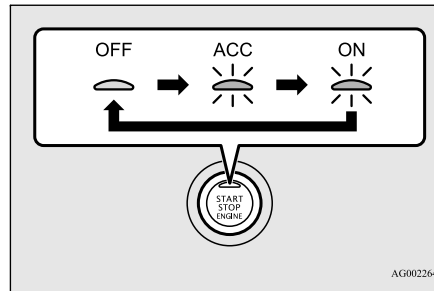

- OFF- The indicator lamp on the engine switch turns off.
- ACC- The indicator lamp on the engine switch illuminates orange.
- ON- The indicator lamp on the engine switch illuminates green.

Refer “Engine switch” on page 6-11.

4-Wiper and washer switch

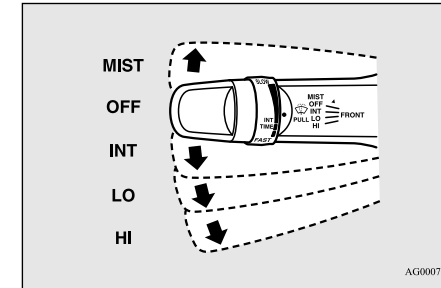

- MIST- Misting function
The wipers will operate once.
- OFF- Off
- INT- Intermittent (Speed sensitive)
- LO- Slow
- HI- Fast

The washer fluid will be sprayed onto the windscreen by pulling the lever towards you.

Refer to “Wiper and washer switch” on page 5-42.

5-Electric remote-controlled outside rear-view mirrors

To adjust the mirror position

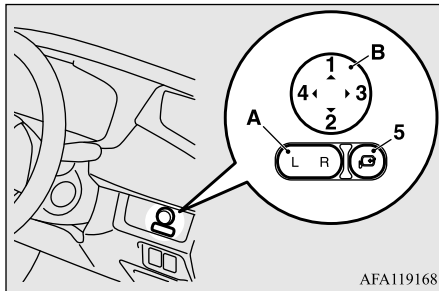

Push the switch (A) to the same side as the mirror whose adjustment is desired.

- L- Left outside mirror adjustment
- R- Right outside mirror adjustment

Press the switch (B) to the left, right, up or down to adjust the mirror position.

- 1- Up
- 2- Down
- 3- Right
- 4- Left
- 5- Mirror retractor switch

Refer “Outside rear-view mirrors: Electric remote-controlled outside rear-view mirrors” on page 6-8.

6-Electric window control

Each door window opens or closes while the corresponding switch is operated.

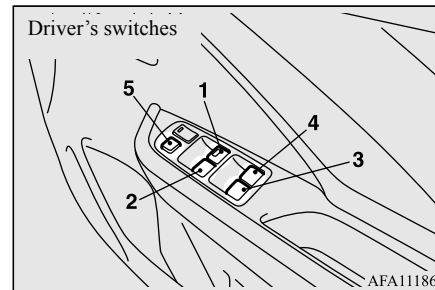

- 1- Driver's door window
- 2- Front passenger's door window
- 3- Rear left door window
- 4- Rear right door window
- 5- Lock switch

Lock switch

When this switch (5) is operated, the passenger's switches cannot be used to open or close the door windows and the driver's switch cannot open or close any door windows other than the driver's door window. To unlock, push it once again.

Refer “Electric window control switch” on page 3-23.

7-Fuel tank filler door release lever

The fuel tank filler is located on the rear left side of your vehicle.

Open the fuel tank filler door with the release lever located the side of the driver's seat.

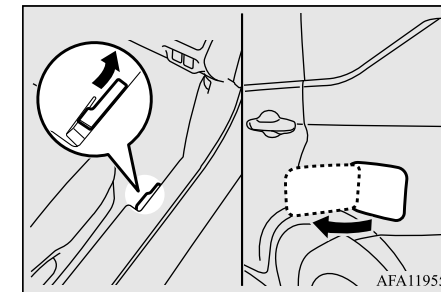

Refer “Filling the fuel tank” on page 2-3.

1 4-speed automatic transmission

E08502700058

Selector lever operation

The transmission has 4 forward gears and 1 reverse gear.

The individual gears are selected automatically, depending on the speed of the vehicle and the position of the accelerator pedal.

The selector lever has 6 positions, and is equipped with a lock button (A) to avoid inadvertent selection of the wrong gear.

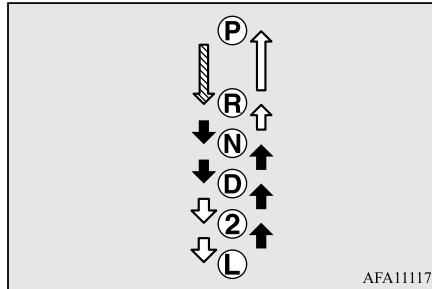
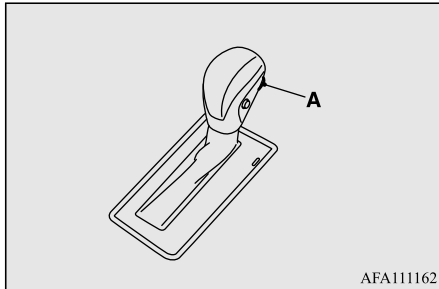

	The lock button must be pressed while the brake pedal is depressed to move the selector lever.
	The lock button must be pressed to move the selector lever.
	The lock button need not be pressed to move the selector lever.

Selector lever positions

“P” PARK

This position locks the transmission to prevent the vehicle from moving. The engine can be started in this position.

“R” REVERSE

This position is to back up.

“N” NEUTRAL

At this position the transmission is disengaged.

“D” DRIVE

This position is for normal driving.

“2” SECOND

This position is for extra power when driving up moderately steep hills, and for engine braking when descending moderately steep gradients.

“L” (LOW)

This position is for driving up very steep hills and for engine braking at low speeds when driving down steep hills.

Overdrive control switch

The overdrive control switch can be used while the selector lever is in the “D” (DRIVE) position.

■ **During normal driving**

Press the overdrive control switch to turn the overdrive function on.

■ **During hilly roads driving**

Press the overdrive control switch to turn the overdrive function off.

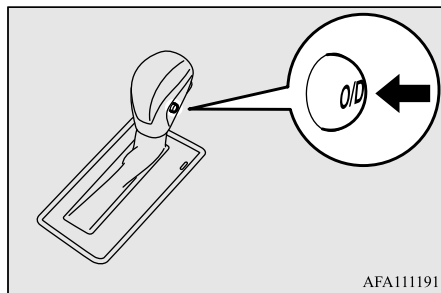

AFA111191

Refer to “4-speed automatic transmission” on page 6-19.

Multi-information display

E08S01201662

Always stop the vehicle in a safe place before operating.

The following information is included on the multi-information display: warnings, odome-

ter, tripmeter, average and momentary fuel consumption, average speed etc.

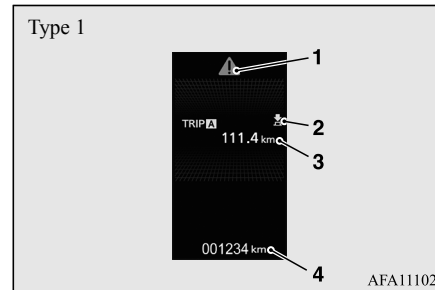

AFA111029

- 1- mark display → P.5-6
- 2- “” or “” mark indicator → P.5-5
- 3- Information screen → P.5-4
Interrupt display screen → P.5-5
- 4- Odometer → P.5-7

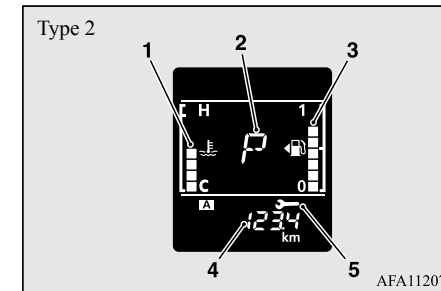

AFA112071

- 1- Engine coolant temperature display → P.5-19
- 2- Selector lever position indicator display → P.6-20
- 3- Fuel remaining display → P.5-19
- 4- Information display → P.5-17
- 5- Service reminder → P.5-20

Refer “Multi-information display - Type 1” on page 5-3 or “Multi-information display - Type 2” on page 5-16.



General information

Fuel selection	2-2
Filling the fuel tank	2-3
Installation of accessories	2-4
Modification/alterations to the electrical or fuel systems	2-5
Genuine parts	2-5
Used engine oils safety instructions	2-6
Event Data Recording	2-6

Fuel selection

2

Fuel selection

E00200105836

Recommended fuel	Unleaded petrol octane number 90 RON or higher
------------------	---

CAUTION

- The use of leaded fuel can result in serious damage to the engine and catalytic converter. Do not use the leaded fuel.

Ethanol (Gasohol)

Vehicles for Sri Lanka

A mixture of up to 10 % ethanol (grain alcohol) and 90 % unleaded petrol may be used in your vehicle, provided the octane number is at least as high as that recommended for unleaded petrol.

CAUTION

- Do not use more than 10 % concentration of ethanol (grain alcohol) by volume. Use of more than 10 % concentration may lead to damage to your vehicle fuel system, engine, engine sensors and exhaust system.

CAUTION

- Do not operate your vehicle on gasoline containing methanol. Using this type of alcohol could adversely affect the vehicle's performance and damage critical parts of the vehicle's fuel system.

NOTE

- Repeatedly driving short distance at low speeds can cause deposits to form in the fuel system and engine, resulting in poor starting and poor acceleration. If these problems occur, you are advised to add a detergent additive to the gasoline when you refuel the vehicle. The additive will remove the deposits, thereby returning the engine to a normal condition. Be sure to use a MITSUBISHI MOTORS GENUINE FUEL SYSTEM CLEANER. Using an unsuitable additive could make the engine malfunction. For details, please contact the nearest authorised MITSUBISHI MOTORS dealer.
- Poor quality petrol can cause problems such as hard starting, stalling, engine noise and hesitation. If you experience these problems, try another brand and/or grade of petrol. If the check engine warning lamp flashes, have the system checked as soon as possible at an authorised MITSUBISHI MOTORS dealer.

Except for vehicles for Sri Lanka

A mixture of up to 20 % ethanol (grain alcohol) and 80 % unleaded petrol may be used in your vehicle, provided the octane number is at least as high as that recommended for unleaded petrol.

CAUTION

- Do not use more than 20 % concentration of ethanol (grain alcohol) by volume. Use of more than 20 % concentration may lead to damage to your vehicle fuel system, engine, engine sensors and exhaust system.
- Do not operate your vehicle on gasoline containing methanol. Using this type of alcohol could adversely affect the vehicle's performance and damage critical parts of the vehicle's fuel system.

NOTE

- Repeatedly driving short distance at low speeds can cause deposits to form in the fuel system and engine, resulting in poor starting and poor acceleration. If these problems occur, you are advised to add a detergent additive to the gasoline when you refuel the vehicle. The additive will remove the deposits, thereby returning the engine to a normal condition. Be sure to use a MITSUBISHI MOTORS GENUINE FUEL SYSTEM CLEANER. Using an unsuitable additive could make the engine malfunction. For details, please contact the nearest authorised MITSUBISHI MOTORS dealer.
- Poor quality petrol can cause problems such as hard starting, stalling, engine noise and hesitation. If you experience these problems, try another brand and/or grade of petrol. If the check engine warning lamp flashes, have the system checked as soon as possible at an authorised MITSUBISHI MOTORS dealer.

Filling the fuel tank

E00200204801

WARNING

- When handling fuel, comply with the safety regulations displayed by garages and filling stations.

WARNING

- Fuel is highly flammable and explosive. You could be burned or seriously injured when handling it. When refuelling your vehicle, always turn the engine off and keep away from flames, sparks, and smoking materials. Always handle fuel in well-ventilated outdoor areas.
- Before removing the fuel cap, be sure to get rid of your body's static electricity by touching a metal part of the car or fuel pump. Any static electricity on your body could create a spark that ignites fuel vapor.
- Perform the whole refuelling process (opening the fuel tank filler door, removing the fuel cap, etc.) by yourself. Do not let any other person come near the fuel tank filler. If you allowed a person to help you and that person was carrying static electricity, fuel vapor could be ignited.
- Do not move away from the fuel tank filler until refuelling is finished. If you moved away and did something else (for example, sitting on a seat) part-way through the refuelling process, you could pick up a fresh charge of static electricity.
- If the tank cap must be replaced, use only a MITSUBISHI MOTORS genuine part.

Fuel tank capacity

45 litres

Refuelling

2

1. Before filling with fuel, stop the engine.
2. The fuel tank filler is located on the rear left side of your vehicle.
Open the fuel tank filler door with the release lever located the side of the driver's seat.

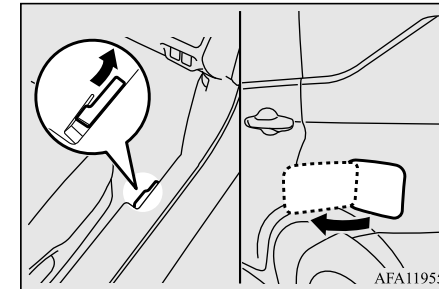

3. Open the fuel tank filler tube by slowly turning the cap anticlockwise.

Installation of accessories

2

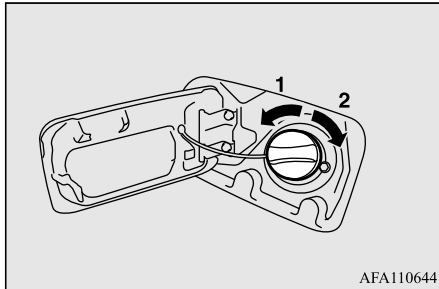

- 1- Remove
- 2- Close

CAUTION

- Since the fuel system may be under pressure, remove the fuel tank filler tube cap slowly. This relieves any pressure or vacuum that might have built up in the fuel tank. If you hear a hissing sound, wait until it stops before removing the cap. Otherwise, fuel may spray out, injuring you or others.

NOTE

- While filling with fuel, store the cap in the cap holder located on the inside of the fuel tank filler door.

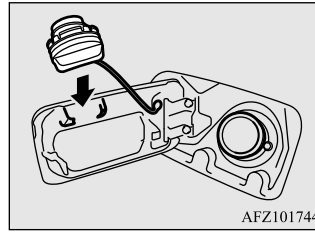

4. Insert the gun in the tank port as far as it goes.

CAUTION

- Do not tilt the gun.

5. When the gun stops automatically, do not fill with fuel any more.
6. To close, turn the fuel tank filler tube cap slowly clockwise until you hear clicking sounds, then gently push the fuel tank filler door closed.

Installation of accessories

E00200302707

Before fitting any accessories, please consult an authorised MITSUBISHI MOTORS dealer.

CAUTION

- Your vehicle is equipped with a diagnosis connector for checking and servicing the electronic control system. Do not connect a device other than a diagnosis tool for inspections and service to this connector. Otherwise, the battery could be discharged, the electronic devices of the vehicle could malfunction, or other unexpected problems could result. In addition, malfunctions caused by connecting a device other than a diagnosis tool may not be covered under warranty.

- The installation of accessories, optional parts, etc., should only be carried out within the limits prescribed by law in your country, and in accordance with the guidelines and warnings contained within the documents accompanying this vehicle. Only MITSUBISHI MOTORS approved accessories should be fitted to your vehicle.

- Improper installation of electrical parts could cause a fire. Refer to the section entitled “Modifications to and alterations of the electrical or fuel systems” in this owner’s manual.
- Using a cellular phone or radio set inside the vehicle without an external antenna may cause electrical system interference, which could lead to unsafe vehicle operation.
- Tyres and wheels which do not meet specifications must not be used.
For details on wheel and tyre sizes, refer to the section entitled “Specifications”.
- Do not fail to read the accessories manuals prior to the installation of accessories, parts or other modifications to the vehicle!

Important points!

Due to the large number of accessory and replacement parts of different manufactures in the market, it is not possible, not only for MITSUBISHI MOTORS CORPORATION, but also an authorised MITSUBISHI MOTORS dealer, to check whether the attachment or installation of such parts affects the driving safety of your vehicle.

Even when such parts are officially authorised, for example by a “general operators per-

mit” (an appraisal for the part) or through the execution of the part in an officially approved manner of construction, or when a single operation permit following the attachment or installation of such parts, it cannot be deduced from that alone, that the driving safety of your vehicles has not been affected.

Consider also that there basically exists no liability on the part of the appraiser or the official. Only in the case of parts (MITSUBISHI MOTORS original replacement or exchange parts as well as MITSUBISHI MOTORS accessories) that are recommended and released by an authorised MITSUBISHI MOTORS dealer and that are attached or installed by an authorised MITSUBISHI MOTORS dealer can you assume, that optimal safety has been provided. The same also pertains to modifications of vehicles with respect to the production specifications. For your own safety, in such cases as well, you should only undertake modifications according to the recommendations of an authorised MITSUBISHI MOTORS dealer.

Modification/alterations to the electrical or fuel systems

E00200401600

2

MITSUBISHI MOTORS has always manufactured safe, high quality vehicles. In order to maintain this safety and quality, it is important that any accessory that is to be fitted, or any modifications carried out which involve the electrical or fuel systems, should be carried out in accordance with MITSUBISHI MOTORS guidelines.

⚠ CAUTION

- Please consult an authorised MITSUBISHI MOTORS dealer concerning any such fitment or modification.
If the wires interfere with the vehicle body or improper installation methods are used (protective fuses not included, etc.), electronic devices may be adversely affected, resulting in a fire or other accident.

Genuine parts

E00200502099

Don’t play around with substitutes. MITSUBISHI MOTORS has gone to great lengths to bring you a superbly crafted vehicle offering the highest quality and dependability. Don’t reduce that quality and dependability by using substitute parts.

Used engine oils safety instructions

2

Always use MITSUBISHI MOTORS Genuine Parts designed and manufactured to maintain your vehicle at top performance. The operation of vehicle components can be less efficient in case of using Non-Genuine Parts. Failure to use Genuine Parts may invalidate any future warranty claim. MITSUBISHI MOTORS will not be liable for any malfunction of your vehicle that may have been caused by the use of substitute parts in place of MITSUBISHI MOTORS Genuine Parts. At the MITSUBISHI MOTORS dealer you can also get appropriate advice and the assembling of Genuine Parts will be handled professionally.

MITSUBISHI MOTORS Genuine Parts are indicated as GENUINE PARTS, and are available at all authorised MITSUBISHI MOTORS dealers.

Used engine oils safety instructions

E00200601501

WARNING

- Prolonged and repeated contact may cause serious skin disorders, including dermatitis and cancer.
- Avoid contact with the skin as far as possible and wash thoroughly after any contact.
- Keep out of reach of children.

Event Data Recording

E00205900166

This vehicle is equipped with an event data recorder (EDR).

The main purpose of an EDR is to record, in certain crash or near crash-like situations, such as an airbag deployment or hitting a road obstacle, data that will assist in understanding how a vehicle's systems performed. The EDR is designed to record data related to vehicle dynamics and safety systems for a short period of time, typically 30 seconds or less.

The EDR in this vehicle is designed to record such data as:

- How various systems in your vehicle were operating;
- How far (if at all) the driver was depressing the accelerator and/or brake pedal; and,
- How fast the vehicle was travelling.

These data can help provide a better understanding of the circumstances in which crashes and injuries occur.

NOTE

- EDR data are recorded by your vehicle only if a non-trivial crash situation occurs; no data are recorded by the EDR under normal driving conditions and no personal data (e.g., name, gender, age, and crash location) are recorded. However, other parties, such as law enforcement, could combine the EDR data with the type of personally identifying data routinely acquired during a crash investigation.

To read data recorded by an EDR, special equipment is required, and access to the vehicle or the EDR is needed. In addition to the vehicle manufacturer, other parties, such as law enforcement, that have the special equipment, can read the information if they have access to the vehicle or the EDR.

Locking and unlocking

Keys	3-2
Electronic immobilizer (Anti-theft starting system)	3-3
Keyless entry system	3-4
Keyless operation system*	3-7
Doors	3-15
Central door locks	3-16
“Child-protection” rear doors	3-17
Tailgate	3-17
Security alarm system	3-19
Electric window control	3-23

Keys

Keys

E00300104768

3

Keyless entry key

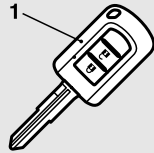

Keyless operation key

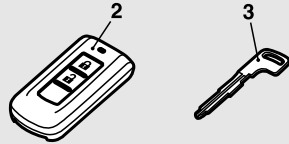

AH3100577

- 1- Keyless entry key
- 2- Keyless operation key
- 3- Emergency key

WARNING

- **When taking a key on flights, do not press any switches on the key while on the plane. If a switch is pressed on the plane, the key emits electromagnetic waves, which could adversely affect the plane's flight operation.**
When carrying a key in a bag, be careful that no switches on the key can be easily pressed by mistake.

NOTE

- The key (except for the emergency key) is a precision electronic part with a built-in signal transmitter. Please observe the following in order to prevent a malfunction.
- Do not leave anywhere that is exposed to direct sunlight, for example on the dashboard.
- Do not disassemble or modify.
- Do not excessively bend the key or subject it to a strong impact.
- Do not expose to water.
- Keep away from magnetic key rings.
- Keep away from audio systems, personal computers, TVs, and any other equipment that generates a magnetic field.
- Keep away from devices that emit strong electromagnetic waves, such as cellular phones, wireless devices and high frequency equipment (including medical devices).
- Do not wash with ultrasonic cleaners or similar equipment.
- Do not leave the key where it may be exposed to high temperature or high humidity.
- The engine is designed so that it will not start if the ID code registered in the immobilizer computer and the key's ID code do not match. For details on that and on key usage, refer to the section entitled "Electronic immobilizer".

NOTE

- Pay attention to the following if the security alarm is set to "Active". Refer to "Security alarm system" on page 3-19.
- If the security alarm is in the system armed mode, the alarm will sound if the doors are opened after being unlocked with the key, the inside lock knob or the central door lock switch.
- Even if the security alarm is set to "Active", the system preparation mode is not entered if the keyless entry system or the keyless operation function was not used to lock the vehicle.

Key number tag

E00314000122

The key number is stamped on the tag as indicated in the illustration.

Make a record of the key number and store the key and key number tag in separate places, so that you can order a key from your authorised MITSUBISHI MOTORS dealer in the event the original keys are lost.

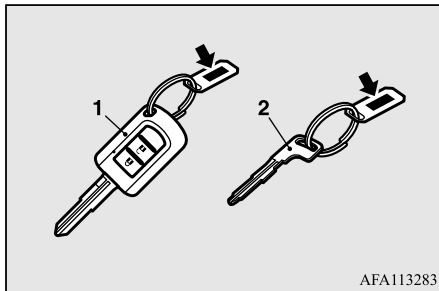

- 1- Keyless entry key
- 2- Emergency key

Electronic immobilizer (Anti-theft starting system)

E00300204121

CAUTION

- Don't make any alterations or additions to the immobilizer system; alterations or additions could cause failure of the immobilizer.

The electronic immobilizer is designed to reduce significantly the possibility of vehicle theft. The purpose of the system is to immobilize the vehicle if an invalid start is attempted. A valid start attempt can only be achieved, using a key "registered" to the immobilizer system.

NOTE

- [Except for vehicles equipped with the keyless operation system]
In the following cases, the vehicle may not be able to receive the registered ID code from the registered key and engine may not start.
- When the key contacts a key ring or other metallic or magnetic object



- When the key grip contacts metal of another key

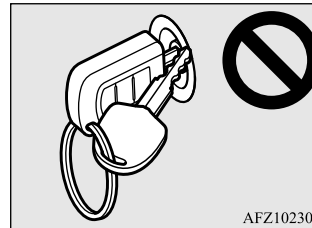

NOTE

- When the key contacts or is close to other immobilizing keys (including keys of other vehicles)

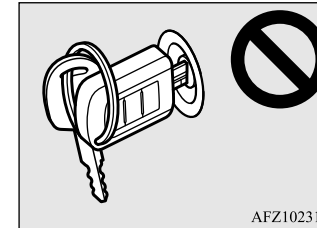

In cases like these, remove the object or additional key from the vehicle key. Then try again to start the engine. If the engine does not start, contact an authorised MITSUBISHI MOTORS dealer.

- [Vehicles equipped with the keyless operation system]
If the engine does not start, we recommend you to contact an authorised MITSUBISHI MOTORS dealer.
- If you lose one of them, contact an authorised MITSUBISHI MOTORS dealer as soon as possible. To obtain a replacement or extra spare key, take your vehicle and all remaining keys to an authorised MITSUBISHI MOTORS dealer. All the keys have to be re-registered in the immobilizer computer unit. For further information, please contact an authorised MITSUBISHI MOTORS dealer.

3

Keyless entry system

Keyless entry system

E00300305233

3

Press the key switch, and all doors and the tailgate will be locked or unlocked as desired. It is also possible to operate the outside rear-view mirrors.

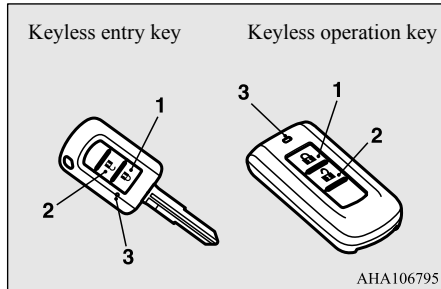

- 1- LOCK switch
- 2- UNLOCK switch
- 3- Indicator lamp

To lock

Press the LOCK switch (1). All the doors and the tailgate will be locked. The turn-signal lamps will blink once. When they are locked with the room lamp switch in the “●” or the “DOOR” position, the room lamp also blink once.

To unlock

Press the UNLOCK switch (2). All the doors and the tailgate will be unlocked. If the room lamp switch is in the “●” or the “DOOR” position at this time, the room lamp will come on for approximately 15 seconds and the turn-signal lamps will blink twice. Also, the position and tail lamps will turn on for approximately 30 seconds. Refer to “Welcome light” on page 5-39 in the section entitled “Instruments and controls”.

NOTE

- The outside rear-view mirrors automatically retract or extend when all the doors and the tailgate are locked or unlocked using the key switches of the keyless entry system. Refer to “Outside rear-view mirrors” on page 6-8 in the section entitled “Starting and driving”.
- If the UNLOCK switch (2) is pressed and no door or tailgate is opened within approximately 30 seconds, relocking will automatically occur.
- It is possible to modify functions as follows: For further information, please contact an authorised MITSUBISHI MOTORS dealer.
 - The time for automatic relocking can be changed.
 - Activating the operation confirmation function (blinking of the turn-signal lamps) only during locking, or only during unlocking.

NOTE

- The confirmation function (this indicates locking or unlocking of the doors and the tailgate with the blink of the turn-signal lamps) can be deactivated.
- The number of times the turn-signal lamps are blinked by the confirmation function can be changed.
- On vehicles equipped with the keyless operation system, the buzzer can be set to sound when the vehicle is locked or unlocked using the switches of the keyless operation key.
- The keyless entry system does not operate in the following conditions:
 - The key is left in the ignition switch. (except for vehicles equipped with the keyless operation system)
 - The operation mode is not in OFF. (vehicles equipped with the keyless operation system)
 - The door or tailgate is open.
- The key switch will operate within approximately 4 m from the vehicle. However, the operating range of the key switch may change if the vehicle is located near a power station, or radio/TV broadcasting station.
- If either of the following problems occurs, the battery may be exhausted.
 - The key switch is operated at the correct distance from the vehicle, but the doors and the tailgate are not locked/unlocked in response.

NOTE

- The indicator lamp (3) is dim or does not come on.
For further information, please contact an authorised MITSUBISHI MOTORS dealer. If you replace the battery yourself, refer to “Procedure for replacing the key battery” on page 3-5.
- If your key is lost or damaged, please contact an authorised MITSUBISHI MOTORS dealer for a replacement key.
- If you wish to add key, please contact an authorised MITSUBISHI MOTORS dealer. The following numbers of the keys are available.
 - Keyless entry key: up to four different keys
 - Keyless operation key: up to four different keys

Operation of the outside rear-view mirrors

E00310802096

To retract

Locking the doors and tailgate using the LOCK switch (1), the outside rear-view mirrors are retracted automatically.

To extend

Unlocking the doors and tailgate using the UNLOCK switch (2), the outside rear-view mirrors are extended automatically.

NOTE

- Functions can be modified as stated below. Please consult an authorised MITSUBISHI MOTORS dealer.
 - Automatically extend when the driver’s door is closed and the ignition switch is turned to the “ON” position or the operation mode is put in ON.
In addition, automatically retract when the ignition switch is turned to the “LOCK” or “ACC” position or the operation mode is put in OFF or ACC, and the driver’s door is then opened.
 - Automatically extend when the vehicle speed reaches approximately 30 km/h.
 - Deactivate the automatic extension function.

NOTE

The outside rear-view mirrors can be retracted or extended by the following operations, even if changing to the any of above. After pressing the LOCK switch to lock the doors and tailgate, if the LOCK switch is pressed again twice in a row within approximately 30 seconds, the outside rear-view mirrors will retract. After pressing the UNLOCK switch to unlock the doors and tailgate, if the UNLOCK switch is pressed again twice in a row within approximately 30 seconds, the outside rear-view mirrors will extend again.

Procedure for replacing the key battery

E00309502413

WARNING

- **Do not swallow a coin type battery.**
 - **This product contains coin type battery. If a coin type battery is swallowed, it can cause severe internal burns and can lead to death.**
There have been cases where a swallowed battery has caused severe internal burns in just 2 hours.
 - **Keep new and used batteries away from children.**
 - **If the key case does not close securely, stop using the product and keep it away from children.**

Keyless entry system

3

⚠ WARNING

- If you think batteries might have been swallowed or placed inside any part of a person's body, seek immediate medical attention.
- To prevent an explosion or leakage of flammable liquid or gas:
 - Do not replace the battery with an incorrect type. Replace only with the same or equivalent type.
 - Do not dispose of a battery into a fire or incinerator, or by mechanically crushing or cutting the battery.
 - Do not use, store, or take a battery any place where it may be exposed to extremely high temperature or extremely low air pressure.

⚠ CAUTION

- When the key case is opened, be careful to keep water, dust, etc. out. Also, do not touch the internal components.
- Dispose of used battery according to the regulations for the disposal of battery.

📖 NOTE

- You may purchase a replacement battery at an electric appliance store.
- An authorised MITSUBISHI MOTORS dealer can replace the battery for you if you prefer.

1. Before replacing the battery, remove static electricity from your body by touching a metal grounded object.
2. Remove the screw (A) from the key. (Keyless entry key only)

Keyless entry key

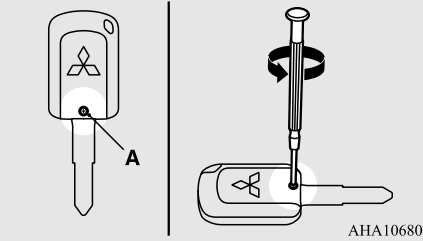

3. Remove the emergency key from the key. (Keyless operation key only)
Refer to "Emergency key" on page 3-11.
4. With the MITSUBISHI mark facing you, insert the cloth-covered tip of a straight blade (or minus) screwdriver into the notch in the key case and use it to open the case.

Keyless entry key

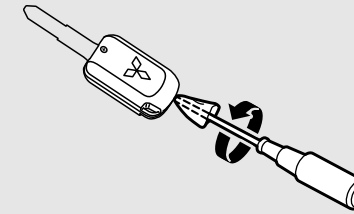

Keyless operation key

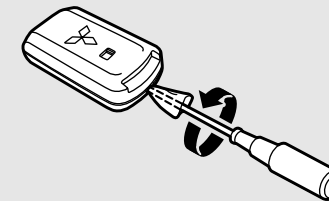

📖 NOTE

- Be sure to perform the procedure with the MITSUBISHI mark facing you. If the MITSUBISHI mark is not facing you when you open the key case, the switches may come out.

5. Remove the used battery.

6. Install a new battery with the + side (B) up.

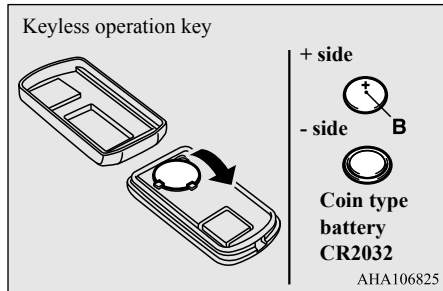
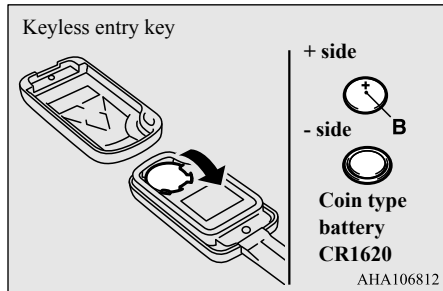

7. Close the key case firmly.
8. Attach the screw (A) removed in step 2. (Keyless entry key only)
9. Install the emergency key removed in step 3. (Keyless operation key only)
10. Check the keyless entry system to see that it works.

Keyless operation system*

E00305602692

The keyless operation system allows you to lock and unlock the doors and the tailgate, start the engine and change the operation mode simply by carrying the keyless operation key with you.

The switches on the keyless operation key can also be used as the key switch of keyless entry system.

Refer to “Starting and stopping the engine” on page 6-15.

Refer to “Keyless entry system” on page 3-4.

The driver should always carry the keyless operation key. This key is necessary for locking and unlocking the doors and the tailgate, starting the engine and otherwise operating the vehicle, so before locking and leaving the vehicle, be sure to check that you have the keyless operation key.

⚠ WARNING

- People with implantable cardiac pacemakers or implantable cardiovascular-defibrillators should not go near the exterior transmitters (A) or the interior transmitters (B). The radio waves used by the keyless operation system could adversely affect implantable cardiac pacemakers or implantable cardiovascular-defibrillators.

Keyless operation system*

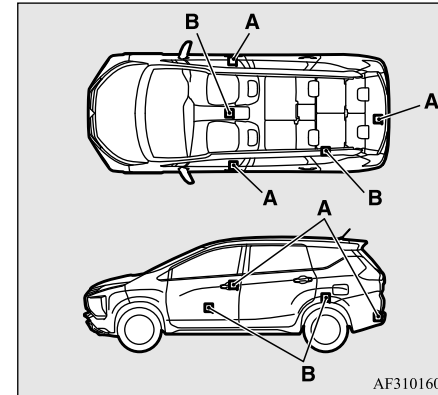

3

⚠ WARNING

- When using electro-medical devices other than implantable cardiac pacemakers or implantable cardiovascular-defibrillators, contact the electro-medical device manufacturer ahead of time to determine the adverse effects of radio waves on the devices. Electro-medical device operations could be affected by radio waves.

You can limit the possible operations of the keyless operation system in the following ways. (The keyless operation system can be used as a keyless entry system.) Please consult an authorised MITSUBISHI MOTORS dealer.

Keyless operation system*

3

- You can limit operations to locking and unlocking the doors and tailgate.
- You can limit operations to starting the engine.
- The keyless operation system can be disabled.

NOTE

- The keyless operation key uses an ultra-weak electromagnetic wave. In the following cases, the keyless operation system may not operate properly or may be unstable.
 - When there is equipment nearby that emits strong radio waves, such as: a power station, a radio/TV broadcasting station or an airport.
 - The keyless operation system is carried together with a communications device such as a cellular phone or radio set, or with an electronic device such as a personal computer.
 - The keyless operation key is touching or covered by a metal object.
 - A keyless entry system is being used nearby.
 - When the keyless operation key battery is worn out.
 - When the keyless operation key is set down in an area with strong radio waves or noise. In such cases, use the emergency key. Refer to “To lock/unlock without using the keyless operation function” on page 3-11.

NOTE

- Because the keyless operation key receives signals in order to communicate with the transmitters in the vehicle, the battery continually wears down regardless of keyless operation key use. The battery life is 1 to 2 years, depending on usage conditions. When the battery wears out, replace the battery according to the description in this manual or have it replaced an authorised MITSUBISHI MOTORS dealer. Refer to “Procedure for replacing the key battery” on page 3-5.
- Because the keyless operation key continually receives signals, strong radio wave reception could affect battery wear. Do not leave the key near a TV, personal computer, or other electronic device.

Operating range of the keyless operation system

E00305701898

If you are carrying the keyless operation key, enter the operating range of the keyless operation system, and press the driver’s or front passenger’s door lock/unlock switch, the tailgate lock/unlock switch, the ID code for your key is verified.

You can lock and unlock the doors and the tailgate, start the engine and change the operation mode only if the ID codes of your keyless operation key and the vehicle match.

NOTE

- If the keyless operation key battery is wearing out or there are strong electromagnetic waves or noise present, the operating range may become smaller and operation may become unstable.

Operating range for locking and unlocking the doors and tailgate

E00306201760

The operating range is approximately 70 cm from the driver’s or front passenger’s door lock/unlock switch, and tailgate lock/unlock switch.

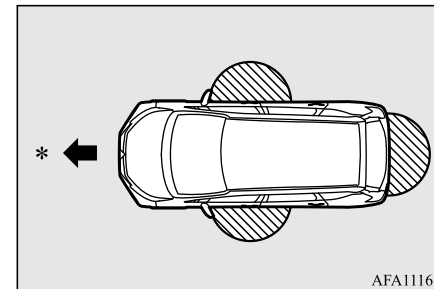

AFA111654

*: Forward direction

: Operating range

NOTE

- Locking and unlocking operate only when you press a door or tailgate switch that detects the keyless operation key.
- Operation may not be possible if you are too close to the front door, door window or tailgate.
- Even if the keyless operation key is within 70 cm of the driver's or front passenger's door lock/unlock switch or tailgate lock/unlock switch, if the key is near to the ground or high up, the system may not operate.
- If the keyless operation key is within the operating range, even someone not carrying the key can lock and unlock the doors and tailgate by pressing the driver's or front passenger's door lock/unlock switch, the tailgate lock/unlock switch.

Operating range for starting the engine and changing the operation mode

E00306301569

The operating range is the interior of the vehicle.

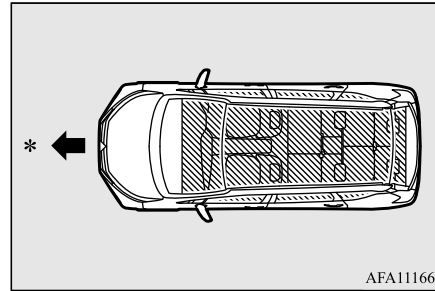

*: Forward direction

: Operating range

NOTE

- Even if it is within the operating range, if the keyless operation key is in a small item holder such as the glove box, on top of the instrument panel, door pocket or in the luggage compartment, it may be impossible to start the engine and change the operation mode.
- If a keyless operation key is too close to the door or door window, it may be possible to start the engine or change the operation mode even when the key is outside the vehicle.

To operate using the keyless operation function

E00305803301

3

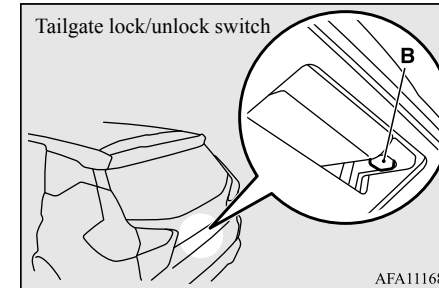
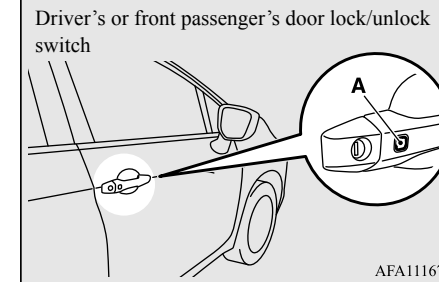

Locking the doors and tailgate

When you are carrying the keyless operation key, if you press the driver's or front passenger's door lock/unlock switch (A), or the tail-

Keyless operation system*

gate lock/unlock switch (B) within the operating range, the doors and the tailgate are locked.

3

The turn-signal lamps will blink once and the outer buzzer will sound once.

For further details, refer to “Doors”, “Central door locks” and “Tailgate” on pages 3-15, 3-16 and 3-17 in the section entitled “Locking and unlocking”.

NOTE

- Be sure to have the keyless operation key with you before locking the vehicle. Even if the keyless operation key is left in the vehicle in the glove box or other small storage compartment, near the instrument panel, or in the luggage compartment, the vehicle may be locked depending on the radio waves and other conditions in the surrounding environment, trapping the key inside the vehicle.
- The outside rear-view mirrors automatically retract when all the doors and tailgate are locked using the keyless operation function. Refer to “Outside rear-view mirrors” on page 6-8.
- The keyless operation function does not operate under the following conditions:
 - The keyless operation key is inside the vehicle.
 - A door or the tailgate is open or ajar.
 - The operation mode is not in OFF.

Unlocking the doors and tailgate

When you are carrying the keyless operation key, if you press the driver’s or front passenger’s door lock/unlock switch (A), or the tailgate lock/unlock switch (B) within the operating range, all the doors and the tailgate are unlocked.

If the room lamp switch is in the “●” or the “DOOR” position at this time, the room lamp will turn on for 15 seconds. The turn-signal lamps will blink twice and the outer buzzer will sound twice.

If the driver’s or front passenger’s door lock/unlock switch is pressed and any of the doors or tailgate is not opened within approximately 30 seconds, relocking will automatically occur.

For further details, refer to “Doors”, “Central door locks” and “Tailgate” on pages 3-15, 3-16 and 3-17 in the section entitled “Locking and unlocking”.

NOTE

- The outside rear-view mirrors automatically extend when all the doors and the tailgate are unlocked using the keyless operation function. Refer to “Outside rear-view mirrors” on page 6-8 in the section entitled “Starting and driving”.
- The keyless operation key does not operate when the operation mode is not in OFF.

NOTE

- The time between unlocking and automatic locking can be adjusted. Please consult an authorised MITSUBISHI MOTORS dealer.

Operation confirmation when locking and unlocking

Operation can be confirmed as shown below. However, the room lamp will illuminate only if the room lamp switch is in the “●” or the “DOOR” position.

When locking: The turn-signal lamps blink once and the outer buzzer sounds once.

When unlocking: The room lamp illuminates for approximately 15 seconds, and the turn-signal lamps blink twice, and the outer buzzer sounds twice.

NOTE

- Functions can be modified as stated below. For further information, please contact an authorised MITSUBISHI MOTORS dealer.
 - Activating the operation confirmation function (blinking of the turn-signal lamps) only during locking, or only during unlocking.
 - Disabling the operation confirmation function (blinking of the turn-signal lamps) and outer buzzer.
 - Changing the number of blinks for the operation confirmation function (blinking of the turn-signal lamps).

To lock/unlock without using the keyless operation function

E00306001221

Emergency key

E00307201839

The emergency key (A) can only be used to lock and unlock the door. To use the emergency key, unlock the lock knob (B) and remove it from the keyless operation key (C).

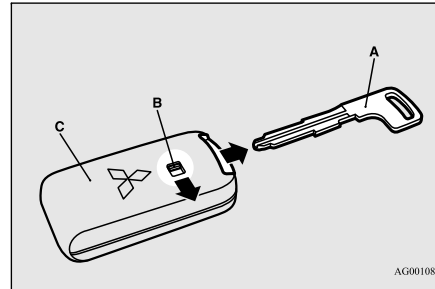

AG0010823

NOTE

- Only use the emergency key for emergencies. If the keyless operation key battery wears out, replace it as quickly as possible so that you can use the keyless operation key.
- The emergency key is built in the keyless operation key.
- After using the emergency key, always return it into the original position.

Locking and unlocking the door

Turning the emergency key in the forward direction locks the door, and turning it in the rear direction unlocks the door. For further details, refer to “Doors” on page 3-15 in the section entitled “Locking and unlocking”.

3

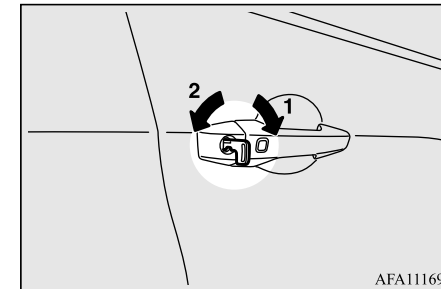

AFA111696

- 1- Lock
- 2- Unlock

Warning activation

E00305902334



In order to prevent vehicle theft or the accidental operation of the keyless operation system, the buzzer and the display on the information screen in the multi-information display are used to alert the driver.



If a warning is activated, always check the vehicle and the keyless operation key. The warning is also displayed if there is a fault in the keyless operation system.

Item	Display	Buzzer	Note (Solution)
Detection of failure		Inner buzzer sounds once	There is a fault in the keyless operation system.

Keyless operation system*

3

Item	Display	Buzzer	Note (Solution)
Fall of battery voltage		Inner buzzer sounds once	The battery starts to run out, the warning is activated. (The warning is not activated if the battery is completely dead.)
Key not detected	Engine switch is pressed one time 	Inner buzzer sounds once	<p>When the engine switch is pressed to change the operation mode from OFF or when the engine is started, the warning is activated, if any of the following conditions has occurred.</p> <ul style="list-style-type: none"> • Carrying another keyless operation key with a different code, or the keyless operation key could be outside the operating range. • The battery of the keyless operation key is dead. • Communication is blocked by electric wave environment. <p>In such case, touch the keyless operation key to the engine switch to change the operation mode or start the engine. Refer to “If the keyless operation key is not operating properly” on page 6-18.</p>
	Engine switch is pressed two times or more 		

Item	Display	Buzzer	Note (Solution)
Keyless operation key take-out monitoring system		Inner buzzer sounds once Outer buzzer sounds intermittently	<ul style="list-style-type: none"> When the vehicle is parked with the operation mode in any mode other than OFF, if you close the door after opening any of the doors and taking the keyless operation key out of the vehicle, a warning is issued until the key is detected in the vehicle. If you take the keyless operation key out of the vehicle through a window without opening a door, the keyless operation key take-out monitoring system does not operate. It is possible to change the setting to make the keyless operation key take-out monitoring system operate if you take the keyless operation key out from the vehicle through a window without opening a door. For further information, please contact an authorised MITSUBISHI MOTORS dealer. Even if you have the keyless operation key within the engine start operating range, if the keyless operation key and vehicle ID codes cannot be matched, for example due to the ambient environment or electromagnetic conditions, the warning may be activated.
Key lock-in prevention system		Inner buzzer sounds once Outer buzzer sounds approximately 3 seconds intermittently	<ul style="list-style-type: none"> When the operation mode is in OFF, if you close all the doors and the tailgate with the keyless operation key left in the vehicle and you try to lock the doors and tailgate by pressing the driver's or front passenger's door lock/unlock switch, or the tailgate lock/unlock switch, a warning is issued and you cannot lock the doors and tailgate. Make sure you have the keyless operation key with you before locking the doors. Even if you leave the keyless operation key inside the vehicle, it is possible that the doors will lock depending on the surrounding environment and wireless signal conditions.
Door ajar prevention system		Inner buzzer sounds once Outer buzzer sounds approximately 3 seconds intermittently	When the operation mode in OFF, if you try to lock the doors and tailgate by pressing the driver's or front passenger's door lock/unlock switch, or the tailgate lock/unlock switch with one of the doors or the tailgate not completely closed, a warning is issued and you cannot lock the doors and tailgate.

Keyless operation system*

3

Item	Display	Buzzer	Note (Solution)
Operation mode OFF reminder system		Inner buzzer sounds once Outer buzzer sounds approximately 3 seconds intermittently	When the operation mode is in any mode other than OFF, if you try to lock the doors and tailgate by pressing the driver's or front passenger's door lock/unlock switch, or the tailgate lock/unlock switch, a warning is issued and you cannot lock the doors and tailgate.

Doors

E00300403908

⚠ CAUTION

- Make sure the doors are closed: driving with doors not completely closed is dangerous.
- Never leave children in the vehicle unattended.
- Be careful not to lock the doors while the key is inside the vehicle.

To lock or unlock with the key

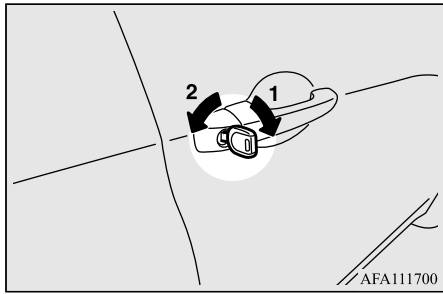

1- Lock
2- Unlock

NOTE

- When locking or unlocking with the key, all doors and the tailgate will be locked or unlocked. Refer to “Central door locks” on page 3-16.
- If the vehicle is equipped with the keyless operation system, all doors and the tailgate can be locked or unlocked with the emergency key. Refer to “Emergency key” on page 3-11.

To lock or unlock from inside the vehicle

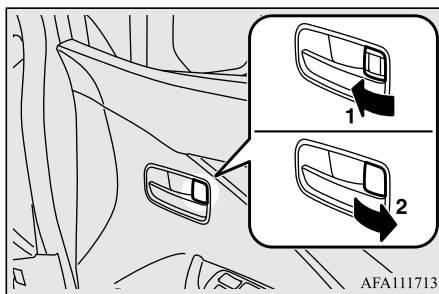

1- Lock
2- Unlock

NOTE

- The driver’s door can be opened without using the lock knob by pulling on the inside door handle.

3

To lock without using the key

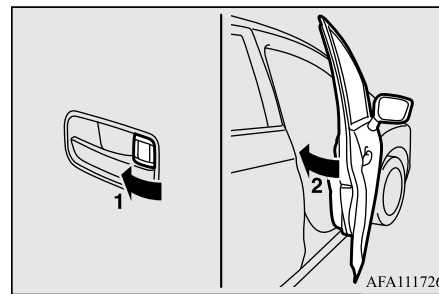

Set the inside lock knob (1) to the locked position, and close the door (2).

Ignition key reminder

E00300501152

Except for vehicles equipped with the keyless operation system

If the driver’s door is opened while the key is in the ignition switch, a buzzer will sound to remind you to remove the key.

Central door locks

Vehicles equipped with the keyless operation system

3

If the driver's door is opened with the engine stopped and the operation mode in any mode other than OFF, a buzzer will sound to remind you to put the operation mode in OFF. Refer to "Operation mode ON reminder system" on page 6-13.

"Forgotten-key-prevention" mechanism

E00300601397

If the key is in the ignition switch or the operation mode is in any mode other than OFF, the lock knob will automatically return to the unlocked position if you push the lock knob forward or press the central door lock switch to lock the doors with the driver's door open.

Central door locks

E00300803713

NOTE

- Repeated continuous operation between lock and unlock could activate the central door locking systems built-in protection circuit and prevent the system from operating. If this occurs, wait approximately 1 minute before operating the central door lock system.

All of the doors and the tailgate can be locked and unlocked as described hereafter.

Driver's door with key

Using the key on the driver's door locks or unlocks all doors and the tailgate.

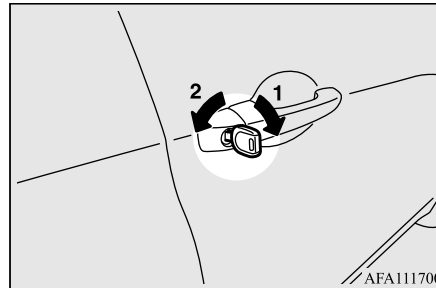

1- Lock

2- Unlock

NOTE

- If the vehicle is equipped with the keyless operation system, the driver's door can be locked or unlocked with the emergency key. Refer to "Emergency key" on page 3-11.

The central door lock switch

Using the central door lock switch on the driver's door locks or unlocks all doors and the tailgate.

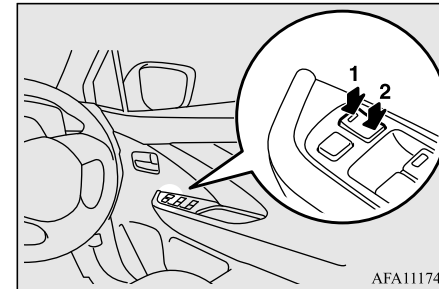

1- Lock
2- Unlock

Unlock using the ignition switch, the engine switch or the selector lever

It is possible to unlock all of the doors and the tailgate whenever as follows.

The selector lever placed the “P” (PARK) position while the ignition switch or the operation mode is in ON.

Or the ignition switch is turned to the “LOCK” position or the operation mode is put in OFF.

These functions are deactivated when the vehicle is shipped from the factory. If you wish to activate or deactivate these functions, please contact an authorised MITSUBISHI MOTORS dealer.

“Child-protection” rear doors

E00300902270

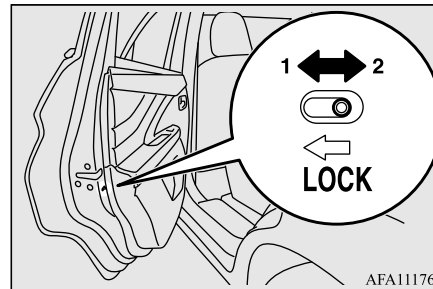

- 1- Lock
- 2- Unlock

Child protection helps prevent the rear doors from being opened accidentally from the inside.

If the lever is set to the locked position, the rear door cannot be opened using the inside handle, but only with the outside handle.

If the lever is set to the unlock position (2), the child protection mechanism does not function.

CAUTION

- When driving with a child in the rear seat, please use the child protection to prevent accidental door opening which may cause an accident.

3

Tailgate

E00301403022

WARNING

- **Luggage compartment is not designed to ride for people. Do not let people ride or children play there. This could result in a serious accident.**
- **It is dangerous to drive with the tailgate open, since carbon monoxide (CO) gas can enter the cabin. You cannot see or smell CO. It can cause unconsciousness and even death. And also, if opening the tailgate while driving, luggage may fall from the tailgate. This could result in a serious accident.**
- **When opening and closing the tailgate, make sure of the surrounding safety and keep enough space for back and upper of the vehicle and be careful not to hit your head or pinch your hands, neck, etc.**

Tailgate

3

WARNING

- When there is a build up of snow or ice, it should be removed before opening the tailgate. If you open the tailgate without removing it, there is a possibility that the tailgate may close suddenly due to the weight of that snow or ice.
- When you open the tailgate make sure that the tailgate is opened fully and remains fully open. If you only open the tailgate halfway there is a risk that the tailgate may drop and slam shut. If you open the tailgate while your vehicle is parked on an incline it is more difficult to do so than on the flat and also it may drop and slam shut.

CAUTION

- Do not stand behind the exhaust pipe when loading and unloading luggage. Heat from the exhaust could lead to burns.
- To avoid damage to the tailgate, make sure the area above and behind the tailgate is clear before opening it.

To lock/unlock

The tailgate can be locked or unlocked by using the central door lock switch (driver side).

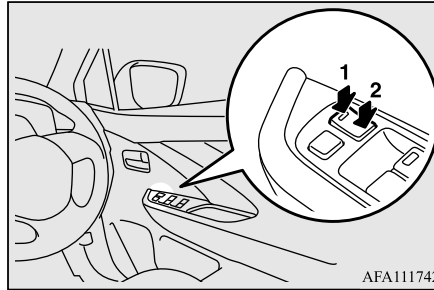

- 1- Lock
- 2- Unlock

NOTE

- Repeated continuous operating between lock and unlock could cause the central door locks' built-in protection circuit to prevent the system from operating. If this occurs, wait approximately 1 minute before operating the central door lock switch.

To open

Unlock the tailgate, and then lift the tailgate while pulling the handle.

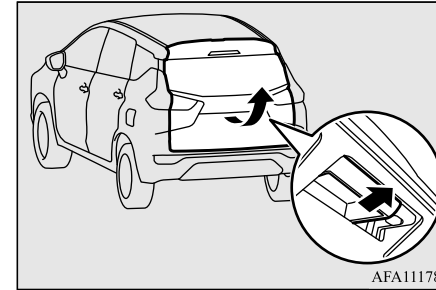

To close

Pull the tailgate grip (A) downward as illustrated. Gently slam the tailgate from the outside so that it is completely closed. Always ensure the tailgate is securely closed.

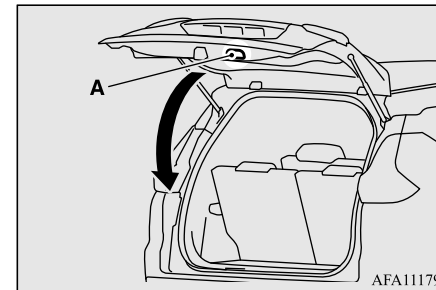

CAUTION

- When closing the tailgate, do not close it directly putting the hands on the tailgate grip. If the hands or arms got caught, a serious injury could result.

NOTE

- Gas struts (B) are installed to support the tailgate.

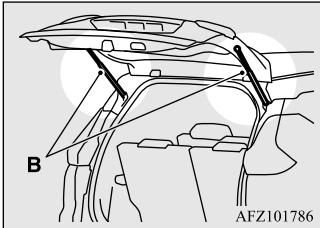

AFZ101786

To prevent damage or faulty operation.

- Do not hold the gas struts when closing the tailgate.
- Also, do not push or pull the gas struts.
- Do not attach any plastic material, tape, etc., to the gas struts.
- Do not tie string, etc., around the gas struts.
- Do not hang any object on the gas struts.

Security alarm system
E00301502550

The security alarm system is for alerting the surrounding area of suspicious behaviour to prevent unlawful entry into the vehicle by operating an alarm if a door or the tailgate is opened when the vehicle has not been unlocked using the keyless entry system or the keyless operation function.

CAUTION

- Do not modify or add parts to the security alarm system. Doing so could cause the security alarm to malfunction.

NOTE

- The alarm system will not be activated if the doors and the tailgate have been locked using a key, the inside lock knob or the central door lock switch (instead of the keyless entry system or the keyless operation function).

The security alarm has four modes:

3

System preparation mode (approximately 20 seconds)

(The buzzer sounds intermittently and the security indicator lamp in the instrument cluster blinks.)

Indicator lamp



The system preparation time extends from the point at which all of the doors and the tailgate are locked by pressing of the LOCK switch on the key or the keyless operation function to the point at which the system armed mode goes into effect.

During this time, it is possible to temporarily open a door or the tailgate without using the keyless entry system or the keyless operation function and without causing the alarm to sound (for example, when you forget something inside the vehicle or realize that a window is open).

Security alarm system

System armed mode

3

(The buzzer stops and the security indicator lamp continues to blink with the indicator's reduced lit-up duration time.)

Once the system preparation mode has ended, the system armed mode starts.

If an unlawful opening of any of the doors or tailgate is detected during the system armed mode, the alarm will be activated to warn people around the vehicle of an abnormal condition.

Also, if unlawful moving of the vehicle is attempted or a vehicle intrusion is detected, the alarm will be activated.

Alarm activation

Inside alarm (approximately 10 seconds):

The buzzer sounds, warning those inside the vehicle of an abnormal condition.

Outside alarm (approximately 30 seconds):

The turn-signal lamps blink and the horn sounds, warning people around the vehicle of an abnormal condition.

Refer to "Alarm activation" on page 3-22.

3-20 Locking and unlocking

NOTE

- The alarm will resume if unlawful actions are taken again, even if the alarm has stopped.

System cancellation

It is possible to cancel the system activation during the system preparation mode or the system armed mode.

In addition, it is possible to cancel the alarm once it has been activated.

Refer to "Cancelling the system" on page 3-21, "Cancelling the alarm" on page 3-22.

NOTE

- When lending the vehicle to another person or allowing the vehicle to be driven by someone who is unfamiliar with the security alarm system, be sure to give the person a proper explanation of the security alarm system. If a person who is unfamiliar with the security alarm system accidentally unlocked the vehicle, causing the alarm to sound, the alarm would be a nuisance to people nearby.

Setting the system

E00301702637

Follow the procedure below to set the system to the system armed mode.

1. Turn the ignition switch to the "LOCK" position and then remove the key (except for vehicles equipped with the keyless operation system), or put the operation mode in OFF (vehicles equipped with the keyless operation system).
2. Exit the vehicle and close all of the doors and tailgate.
3. Press the LOCK switch (A) on the key of the keyless entry system or the keyless operation system, the driver's or front passenger's door lock/unlock switch (B), or the tailgate lock/unlock switch (C) in order to lock all the doors and the tailgate.

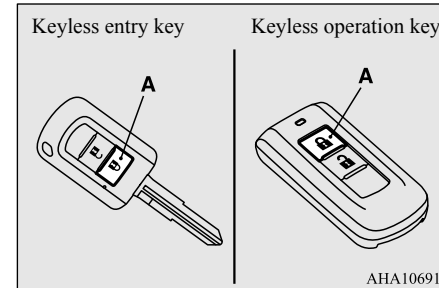

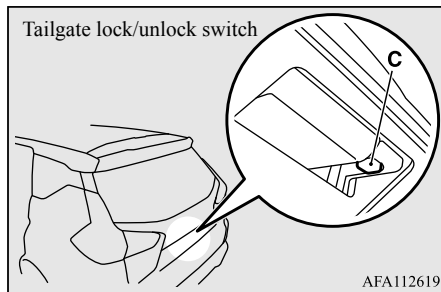
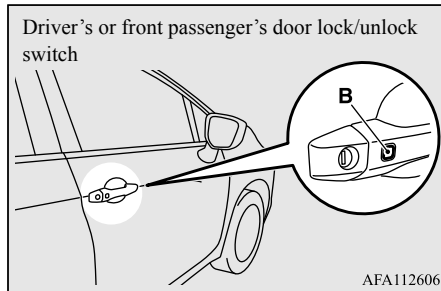

By locking the vehicle using the keyless entry system or the keyless operation function, the system preparation mode is activated.

The buzzer makes an intermittent beeping sound and the security indicator lamp in the instrument cluster flashes for confirmation.

Indicator lamp



NOTE

- The system preparation mode is not activated when the doors and the tailgate have been locked using a method other than the keyless entry system or the keyless operation function (namely a key, the inside lock knob or the central door lock switch).
- If the security indicator lamp in the instrument cluster does not blink after the locking operation using the keyless entry system or the keyless operation function, the security alarm system may be malfunctioning. Have the vehicle inspected at an authorised MITSUBISHI MOTORS dealer.

4. After approximately 20 seconds, the buzzer stops, and when the blinking of the security indicator lamp starts to slow down, the system armed mode goes into effect.

The security indicator lamp continues to blink during the system armed mode.

NOTE

- The security alarm system can be activated when people are riding inside the vehicle or when the windows are open. To prevent accidental activation of the alarm, do not set the system to the system armed mode while people are riding in the vehicle.
- Avoid leaving valuable items inside the vehicle even when the security alarm system has been set to the "active" mode.

3

Cancelling the system

E00301802478

The following methods can be used to cancel the system when it is in the system preparation mode or the system armed mode.

- Pressing the UNLOCK switch on the key.
- Turning the ignition switch to the "ON" position. (except for vehicles equipped with the keyless operation system)
- Putting the operation mode in ON. (vehicles equipped with the keyless operation system)
- Opening any one of the doors or the tailgate, or inserting the key into the ignition switch (except for vehicles equipped with the keyless operation system) when the system is in the system preparation mode.

Security alarm system

3

- Holding the keyless operation key and pressing the driver's or front passenger's door lock/unlock switch, or the tailgate lock/unlock switch to unlock the doors and the tailgate (vehicles equipped with the keyless operation system).

NOTE

- If the battery terminals are disconnected while the system is in the system preparation mode, the memory will be erased.
- It is possible to register up to four keys for keyless entry system and four keys for keyless operation system.
As long as they are registered, any of the keys, other than the one used to activate the system, can be used to cancel the system.
If you want to register additional keys, please contact an authorised MITSUBISHI MOTORS dealer.
- The activation distance for keyless entry system is approximately 4 m.
If it is not possible to lock or unlock the vehicle by pressing the switch at the correct distance or the security alarm system cannot be set or cancelled using the switch, the battery may need to be replaced.
Replace the battery at your authorised MITSUBISHI MOTORS dealer.

NOTE

- If the UNLOCK switch on the key, the driver's or front passenger's door lock/unlock switch, or the tailgate lock/unlock switch is pressed and no door or the tailgate is opened within 30 seconds, the doors and the tailgate will automatically relock. In this case as well, the system preparation mode will go into effect.
- The time between pressing of the UNLOCK switch on the key, the driver's or front passenger's door lock/unlock switch, or the tailgate lock/unlock switch and automatic locking can be adjusted. Please consult an authorised MITSUBISHI MOTORS dealer.

Alarm activation

E00301902512

When the system is in the system armed mode, the alarm will be activated as follows if the vehicle is unlocked or if any of the doors or tailgate is opened using a method other than the keyless entry system or the keyless operation function.

1. The inside alarm will be activated for approximately 10 seconds.
2. The alarm will be activated for approximately 30 seconds.
The turn-signal lamps will flash, and the horn will sound intermittently.

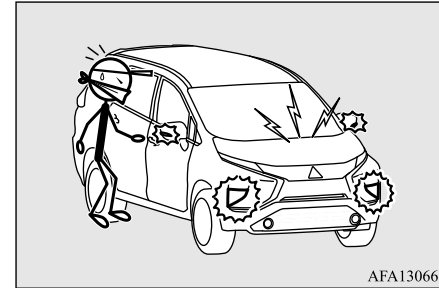

3. The alarm will resume if unlawful actions are taken again, even if the alarm has stopped.

Cancelling the alarm

E00302001946

It is possible to halt the activation of an alarm using the following methods:

- Pressing the LOCK or UNLOCK switch on the key.
(After pressing of the LOCK switch, the vehicle will lock if all the doors and the tailgate are closed, after which the system preparation mode will once again go into effect.)
- Turning the ignition switch to the "ON" position. (except for vehicles equipped with the keyless operation system)

- Putting the operation mode in ON. (vehicles equipped with the keyless operation system)
- Holding the keyless operation key and locking or unlocking the doors and the tailgate using the keyless operation function (vehicles equipped with the keyless operation system).

NOTE

- When the ignition switch is turned to the “ON” position or the operation mode is put in ON, the buzzer sounds four times. This operation indicates that the alarm was activated while the vehicle was parked. Please check the inside of the vehicle to confirm that nothing was stolen.
- Even if the battery is disconnected, the alarm activation memory will not be erased.

Electric window control

E00302201850

The electric windows can only be operated with the ignition switch in the “ON” position or the operation mode in ON.

Electric window control switch

E00302303695

Each door window opens or closes while the corresponding switch is operated.

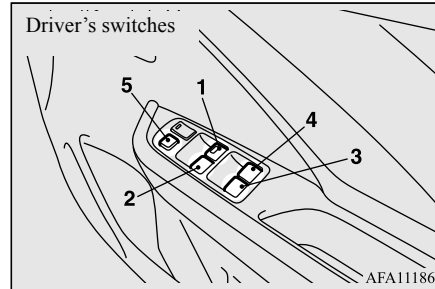

- 1- Driver’s door window
- 2- Front passenger’s door window
- 3- Rear left door window
- 4- Rear right door window
- 5- Lock switch

WARNING

- Before operating the electric window control, make sure that nothing is capable of being trapped (head, hand, finger, etc.).
- Never leave the vehicle without removing the key.
- Never leave a child (or other person who might not be capable of safe operation of the electric window control) in the vehicle alone.

Driver’s switches

The driver’s switches can be used to operate all door windows. A window can be opened or closed by operating the corresponding switch.

Press the switch down to open the window, and pull up the switch to close it.

If the switch for the driver’s window is fully pressed down/pulled up, the door window automatically opens/closes completely.

If you want to stop the window movement, operate the switch lightly in the reverse direction.

3

Passenger’s switches

The passenger’s switches can be used to operate the corresponding passenger’s door windows.

Press the switch down for opening the window, and pull up the switch for closing.

Electric window control

3

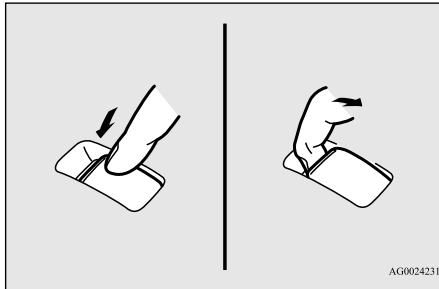

NOTE

- Repeated operation with the engine stopped will run down the battery. Operate the window switches only while the engine is running.
- The rear door windows only open halfway.

Lock switch

E00303102749

When this switch is operated, the passenger's switches cannot be used to open or close the door windows and the driver's switch cannot open or close any door windows other than the driver's door window.

To unlock, push it once again.

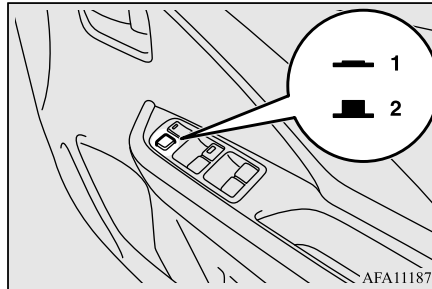

- 1- Lock
- 2- Unlock

WARNING

- A child may tamper with the switch at the risk of its hands or head being trapped in the window. When driving with a child in the vehicle, please push the window lock switch to disable the passenger's switches.

Timer function

E00302402266

The door windows can be opened or closed for 30 seconds after the engine is stopped. However, once the driver's door or the front passenger's door is opened, the windows cannot be operated.

Safety mechanism (driver's window only)

E00302502339

When the door window is automatically closed by pulling up the switch fully, if a hand or head is trapped in the closing window, it will lower automatically.

Nonetheless, make sure that nobody puts their head or hand out of the window when closing the driver's door window.

The lowered window will become operational after a few seconds.

WARNING

- If the battery terminals are disconnected or the fuse for electric window is replaced, the safety mechanism will be cancelled. If a hand or head got trapped, a serious injury could result.

CAUTION

- The safety mechanism is cancelled just before the window is fully closed. This allows the window to close completely. Therefore be especially careful that no fingers are trapped in the window.
- The safety mechanism is deactivated while the switch is pulled up. Therefore be especially careful that fingers are not trapped in the door window opening.

 **NOTE**

- The safety mechanism can be activated if the driving conditions or other circumstances cause the driver's door window to be subjected to a physical shock similar to that caused by a trapped hand or head.

- If the safety mechanism is activated five or more times in a row, the safety mechanism will be cancelled and the door window will not close correctly.

In such a case, the following procedure should be implemented to rectify this situation. If the window is open, repeatedly raise the driver's door window switch until that window has been fully closed. Following this, release the switch, raise the switch once again and hold it in this condition for at least 1 second, then release it. You should now be able to operate in the normal fashion.

- If the battery terminals are disconnected or the fuse for electric window is replaced, the safety mechanism will be cancelled and the door window will not automatically open/close completely.

If the window is open, repeatedly raise the driver's door window switch until the window has been fully closed. Following this, release the switch, raise the switch once again and hold it in this condition for at least 1 second, then release it. You should now be able to operate the driver's door window in the normal fashion.



Seat and seat belts

Seat arrangement	4-2
Seat adjustment	4-4
Front seats	4-4
Second seats	4-5
Third seats	4-7
Head restraints	4-7
Making a luggage area	4-9
Seat belts	4-10
Pregnant women restraint	4-14
Seat belt pre-tensioner system	4-15
Child restraint	4-15
Seat belt inspection	4-22
Supplemental restraint system (SRS) - airbag	4-23

Seat arrangement

Seat arrangement

E00400202085



By operating the front, second or third seat, select the desired seat arrangement.

4

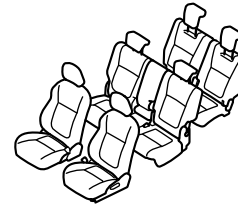
Normal usage

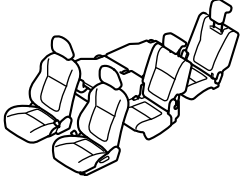
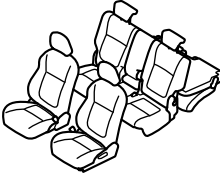

AFM102317

Making a luggage area	Folding the second seat armrest and third seats → P. 4-9	 <p>AFM102434</p>
	Folding the second and third seats → P. 4-9	 <p>AFM102320</p>
		 <p>AFM104089</p>
	Folding the third seats → P. 4-10	 <p>AFM102333</p>

Seat adjustment

Seat adjustment

E00400302233

Adjust the driver's seat so that you are comfortable and that you can reach the pedals, steering wheel, switches etc. while retaining a clear field of vision.

4

! WARNING

- Do not attempt to adjust the seat while driving. This can cause loss of vehicle control and result in an accident. After adjustments are made, ensure the seating is locked in position by attempting to move the seat forward and rearward without using the adjusting mechanism.
- It is extremely dangerous to ride in the luggage area of a vehicle. Also, the luggage area and rear seats should never be used as a play area by children. In a collision, people or children riding unrestrained in these areas are more likely to be seriously injured or killed.
- Do not allow people or children to ride in any area of your vehicle that is not equipped with seats and seat belts, and make sure that everyone travelling in your vehicle is in a seat and wearing a seat belt, or in the case of a child is strapped in a child restraint.

! WARNING

- To minimize the risk of personal injury in the event of a collision or sudden braking, the seatbacks should always be in the almost upright position while the vehicle is in motion. The protection provided by the seat belts may be reduced significantly when the seatback is reclined. There is greater risk that the passenger will slide under the seat belt, resulting in serious injury, when the seatback is reclined.
- Do not place objects under the seats. This could prevent the seat from locking securely, and it could lead to an accident. It may also cause damage to the seat or other parts.

! CAUTION

- Make sure the seat is adjusted by an adult or with adult supervision for correct and safe operation.
- Do not place a cushion or the like between your back and the seatback while driving. The effectiveness of the head restraints will be reduced in the event of an accident.
- The reclining mechanism of the front seat's seatback is spring loaded, causing it to return to the vertical position when the lock lever is operated. When using the lever, sit close to the seatback or hold it with your hand to control its return motion.
- When sliding the seats, be careful not to catch your hand or foot.

! CAUTION

- When sliding or reclining the seat rearward, pay careful attention to the rear seat passengers.

Front seats

E00400401673

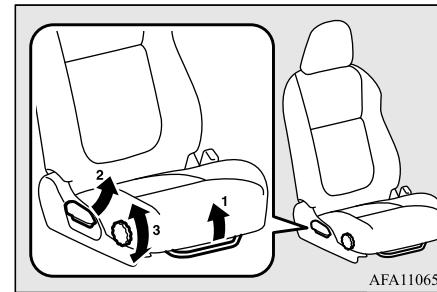

AFA110657

- 1- To adjust forward or backward
Lift the handle and adjust the seat to the desired position, and release the handle.
- 2- To recline the seatback
Pull the lever up and then lean backward to the desired position, and release the lever.
- 3- To adjust seat height (driver's side only)
Turn the dial and adjust the seat cushion height to the desired position.

Second seats

E00402001631

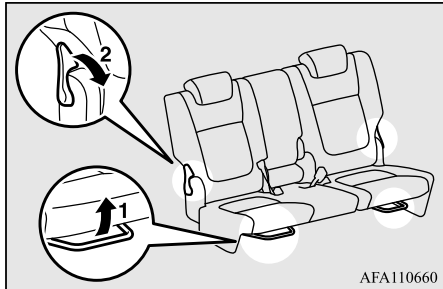

- 1- To adjust forward or backward
Lift the handle and adjust the seat to the desired position, and release the handle.
- 2- To recline the seatback
Pull the lever forward and adjust the seatback by hand to the desired position, and release the lever.

Armrest

E00402401648

To use the armrest, pull forward the strap to release the lock, and fold the armrest down. To return to the original position, push it backward until it is flush with the seat.

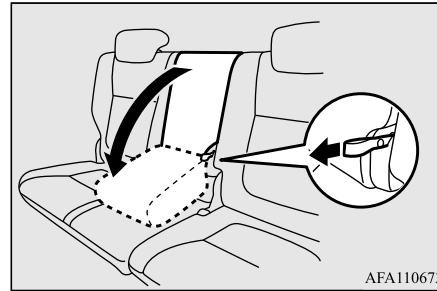

CAUTION

- Do not climb or sit on the armrest. Doing so could damage the armrest.

To get in and out of the third seat

E00412601076

Getting in and out of the third seat can be made easily by folding the second seat.

To fold

1. Adjust the angle of the front seatbacks in the upright position and move the front seat forward. (Refer to “Front seats” on page 4-4.)
2. Store the seat belt buckles in the storage pockets of the second seats.

- Refer to “Second and third seat belt storage” on page 4-14.
3. Lower the head restraints of the second seat to the lowest position. Refer to “Head restraints” on page 4-7.
 4. If the second seat is in the forward-most position, move it rearward.

NOTE

- If the second seats are in a forward position, you may not be able to fold them.

5. Pull the lever (A) forward, then tilt the seatback forward. When the seatback is tilted forward, the floor lock will be released and the rear of the seat will lift up slightly.

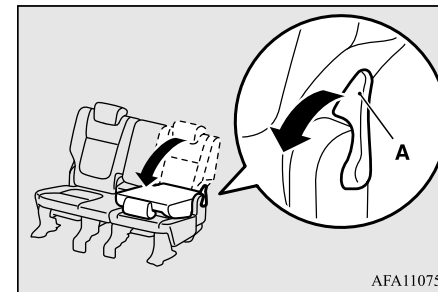

6. Lift the whole seat forward.

Second seats

4

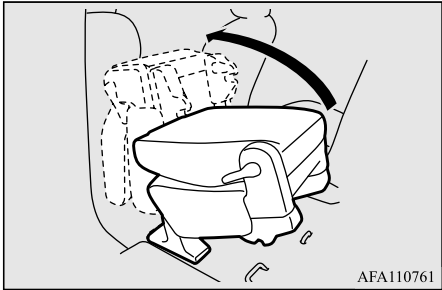

⚠ CAUTION

- Do not drive the vehicle while a second seat is folded. Because the folded second seat is not locked, it could move in the event of hard braking, a collision, or similar situation, striking the occupant of the other second seat and trapping the feet of the third seat occupants, resulting in injuries.

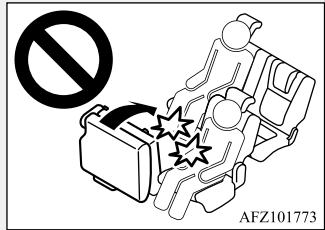

To return

1. While supporting the seat by hand, gently lower the seat.

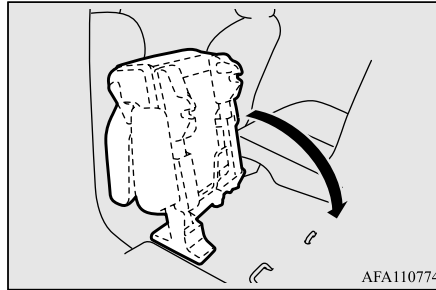

⚠ CAUTION

- When returning the second seat while there is an occupant in the other second seat or occupants in the third seat, be careful not to strike the second seat occupant or trap the feet of the third seat occupants with the second seat.

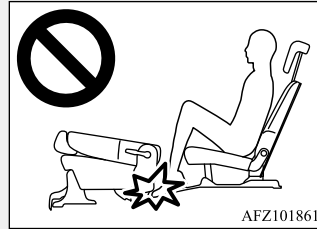

2. Push the seat until you hear a “click” and the seat locks securely to the floor.

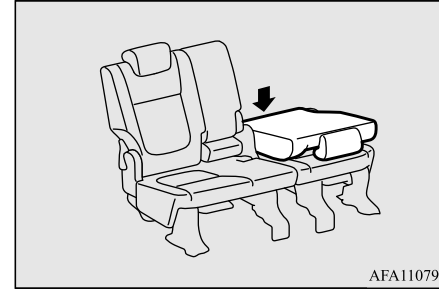

3. Raise the seatback until it locks securely into place.

Push lightly on the seatback to confirm that it has actually been secured.

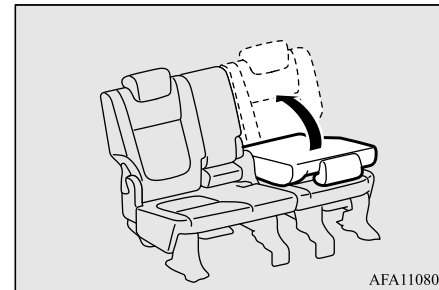

Third seats

E00402701540

⚠ WARNING

- For reasons of safety, whenever passengers sit in the third seat, be sure to raise all the head restraints of the second seats.



AFZ101933

To recline the seatback.
Pull up the strap and adjust the seatback by hand to the desired position, and release the strap.

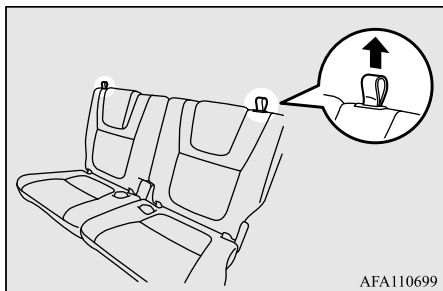

Head restraints

E00403303013

⚠ WARNING

- Driving without the head restraints in place can cause you and your passengers serious injury or death in an accident. To reduce the risk of injury in an accident, always make sure the head restraints are installed and properly positioned when the seat is occupied.
- Never place a cushion or similar device on the seatback. This can adversely affect head restraint performance by increasing the distance between your head and the restraint.

To adjust height

Front seats

Adjust the head restraint height so that the centre of the head restraint is as close as possible to ear level to reduce the chances of injury in the event of collision. Any person too tall for the head restraint to reach their seated ear level, should adjust the restraint as high as possible.

To raise the head restraint, move it upward.
To lower the restraint, move it downward while pushing the height adjusting knob (A)

in the direction of the arrow. After adjustment, push the head restraint downward and make sure that it is locked.

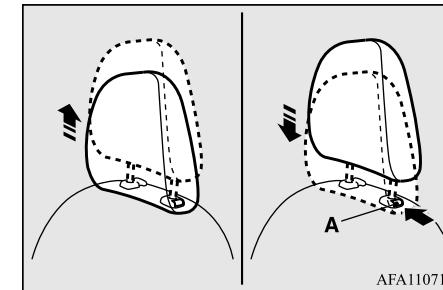

4

Second or third seats

To reduce the risk of injury in an accident, pull up the head restraint to the locked position.

To raise the head restraint, move it upward.
To lower the restraint, move it downward while pushing the height adjusting knob (A) in the direction of the arrow. After adjustment, push the head restraint downward and make sure that it is locked.

Head restraints

4

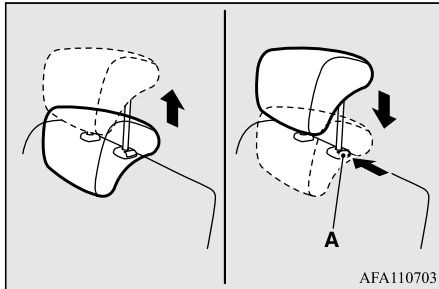

⚠ WARNING

- When a person sits in the second or the third seats, pull up the head restraint to a height at which it locks in position. Be sure to make this adjustment before starting to drive. Serious injuries could otherwise be suffered in the result of an impact.



📖 NOTE

- The head restraints of the third seats cannot be removed.

To remove (front or second seats)

Lift the head restraint with the height adjusting knob (A) pressed in.

To install (front or second seats)

Confirm that the head restraint is facing the correct direction, and then insert it into the seatback while pressing the height adjusting knob (A) in the direction indicated by the arrow.

The head restraint stalk with the adjustment notches (B) must be installed in the hole with the adjusting knob (A).

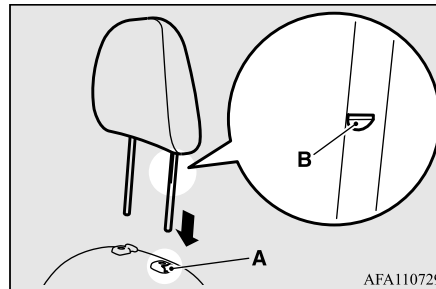

⚠ CAUTION

- Confirm that the height adjusting knob (A) is correctly adjusted as shown in the illustration, and also lift the head restraints to ensure that they do not come out of the seatback.

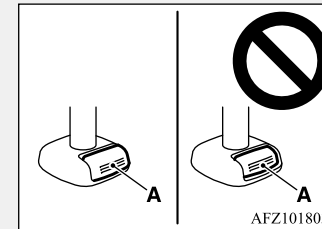

- The shape and size of the head restraint differs according to the seat. Always use the correct head restraint provided for the seat and do not install the head restraint in the wrong direction.



Making a luggage area

E00403401557

To create luggage space, you can fold the second and/or the third seats.

WARNING

- After tilting the seatback of a second seat forward, push down on the rear of the seat and make sure it is securely locked to the floor. The seat could move if it is not retained, causing a serious accident.

CAUTION

- Do not stack luggage above the seatback height or load luggage in such a way that will interfere with the operation of the vehicle. Secure the luggage firmly. Serious accidents could result due to unrestrained objects entering the passenger compartment during sudden braking.
- When folding or storing the seat, be sure not to catch your hand or leg.

NOTE

- It is possible to folding the seat independently on each side.

Folding the second seat armrest and third seats

E00465100038

Long items can be loaded while passengers are sitting in the second row outboard seats.

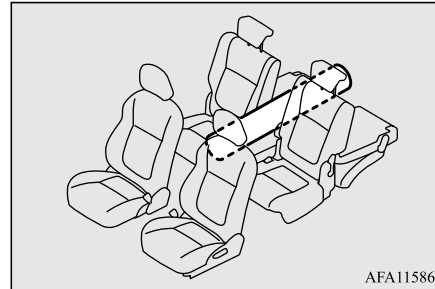

AFA115867

1. Fold the third seats.
Refer to “Folding the third seats” on page 4-10.
2. Fold the armrest down.
Refer to “Armrest” on page 4-5.

Folding the second and third seats

E00403501747

To fold

1. Fold the third seats.

Refer to “Folding the third seats” on page 4-10.

2. Store the seat belt buckles in the storage pockets of the second seats.

Refer to “Second and third seat belt storage” on page 4-14.

3. Lower the head restraints of the second seat to the lowest position.

Refer to “Head restraints” on page 4-7.

4. Move the second seats to the rear-most position.

5. Pull the lever (A) forward, then tilt the seatback forward.

When the seatback is tilted forward, the floor lock will be released and the rear of the seat will lift up slightly.

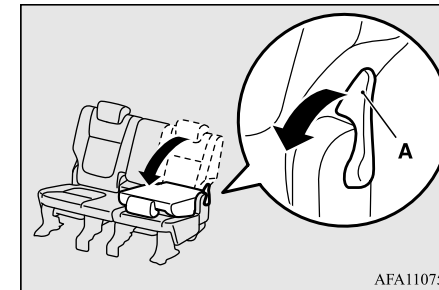

AFA110758

6. Push the seat until you hear a “click” and the seat locks securely to the floor.

4

Seat belts

4

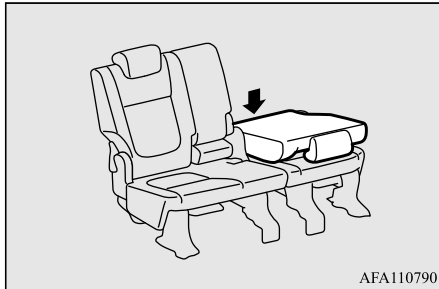

Folding the third seats

E00403601142

To fold

1. Lower the head restraints of the third seat to the lowest position. (Refer to “Head restraints” on page 4-7.)
2. Pull up the strap (A), then fold the seat-back forward.

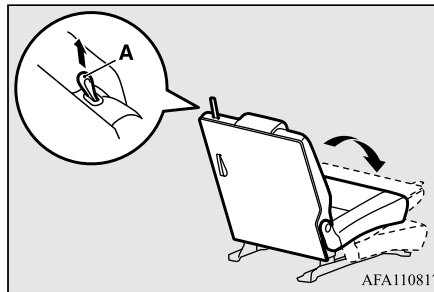

To return

Pull the strap (B), then raise the seatback until it locks securely into place. Push lightly on the seatback to confirm that it has actually been secured.

To return

Raise the seatback until it locks securely into place. Push lightly on the seatback to confirm that it has actually been secured.

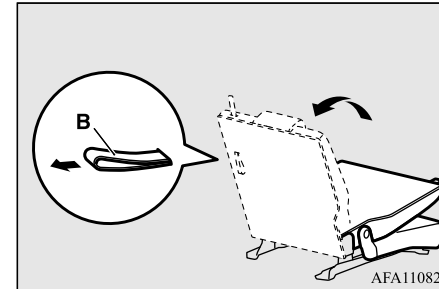
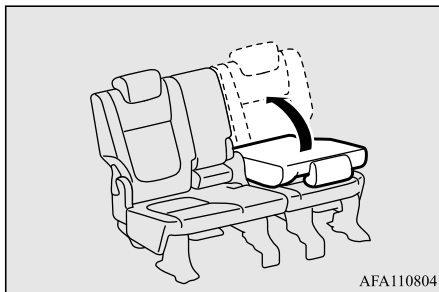

Seat belts

E00404802164

To protect you and your passengers in the event of an accident, it is the most important that the seat belts be worn correctly while driving.

The front seat belts have a pre-tensioner system. These belts are used the same way as a conventional seat belt.

Refer to “Seat belt pre-tensioner system” on page 4-15.

⚠ WARNING

- **Seat belts should always be worn by every adult who drives or rides in this vehicle, and by all children who are large enough to wear seat belts properly. Other children should always use proper child restraint systems.**

⚠ WARNING

- Always place the shoulder belt over your shoulder and across your chest. Never put it behind you or under your arm.
- One seat belt should be used by only one person. Doing otherwise can be dangerous.
- The seat belt will provide its wearer with maximum protection if the recliner seatback is placed in fully upright position. When the seatback is reclined, there is greater risk that the passenger will slide under the belt, especially in a forward impact accident, and may be injured by the belt or by striking the instrument panel or seatbacks.
- Remove any twists when using the belt.
- No modifications or additions should be made by the user which will either prevent the seat belt adjusting devices from operating to remove slack, or prevent the seat belt assembly from being adjusted to remove slack.
- Never hold a child in your arms or on your lap when riding in this vehicle, even if you are wearing your seat belt. To do so risks severe or fatal injury to your child in a collision or sudden stop.
- Always adjust the belt to a snug fit.
- Always wear the lap portion of the belt over your hips.

3-point type seat belt (with emergency locking mechanism)

E00404903234

This type of belt requires no length adjustment. Once worn, the belt adjusts itself to the movement of wearer, but in the event of a sudden or strong shock, the belt automatically locks to hold the wearer's body.

📖 NOTE

- You can check if the belt locks by pulling it forward quickly.

To fasten

1. Pull the seat belt out slowly while holding the latch plate.

📖 NOTE

- When the seat belts cannot be pulled out in a locked condition, pull the belts once forcefully and then return them. After that, pull the belts out slowly once again.

2. Insert the latch plate into the buckle until a "click" is heard.

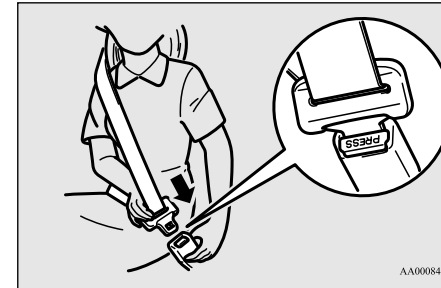

4

⚠ WARNING

- Never wear the lap portion of the belt across your abdomen. During accidents it can press sharply against abdomen and increase the risk of injury.
- The seat belts must not be twisted when worn.

3. Pull the belt slightly to adjust slackness as desired.

Seat belts

To unfasten

Hold the latch plate and push the button on the buckle.

4

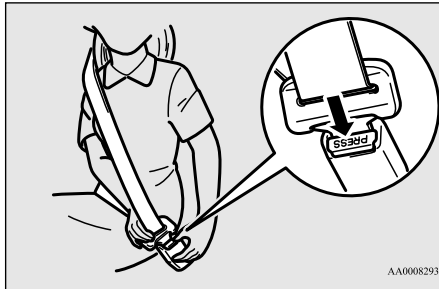

NOTE

- As the belt retracts automatically, keep holding the latch plate while retracting so that the belt stows slowly. Failure to do this could damage the vehicle.

NOTE

- If the seat belt (A) or ring (B) becomes dirty, the belt may not retract smoothly. If the seat belt and ring are dirty, clean them with a mild soap or detergent solution.

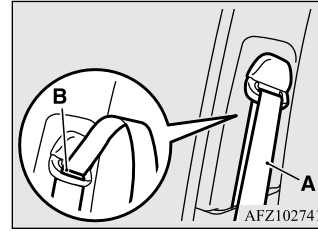

Seat belt reminder

E00409802534

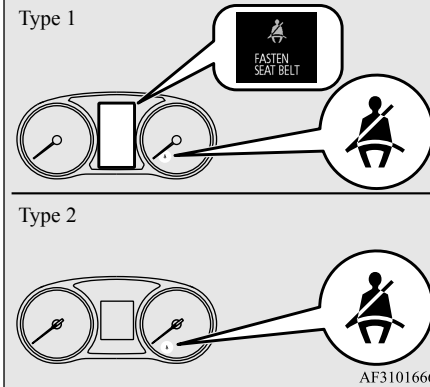

If the ignition switch is turned to the “ON” position or the operation mode is put in ON while the seat belt is not fastened, the warning lamp comes on and the tone sounds for approximately 6 seconds to remind the driver and the front passenger to fasten the seat belt. If the vehicle is driven with the seat belt still unfastened, the warning lamp will blink and the tone will sound intermittently until the seat belt is fastened. At the same time, “FASTEN SEAT BELT” is displayed on the information screen in the multi-information display (Type 1 only).

WARNING

- Do not install any accessory or sticker that makes the lamp difficult to see.

NOTE

- If the seat belt subsequently remains unfastened, the warning lamp and the tone will issue further warnings each time the vehicle starts moving from a stop.
- For the front passenger seat, the warning function works only while a person is sitting on the seat.
- When luggage is placed on the front passenger seat, a sensor in the seat cushion may, depending on the weight and position of the luggage, cause the warning tone to sound and the warning lamp to come on.

Second-centre 3-point type seat belt

E00405201298

The second-centre 3-point type seat belt must be worn correctly as illustrated.

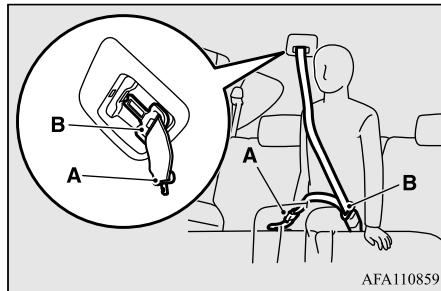

⚠ WARNING

- Be sure to securely connect the both latch plate (A and B). Failing to do so could significantly reduce the amount of protection and cause serious injuries in a collision or a sudden stop.

To fasten

1. Pull out the buckle (C) from the seat cushion.
2. Pull the seat belt and insert the small latch plate (A) into the buckle (C).

3. Insert the latch plate (B) into the buckle (D).

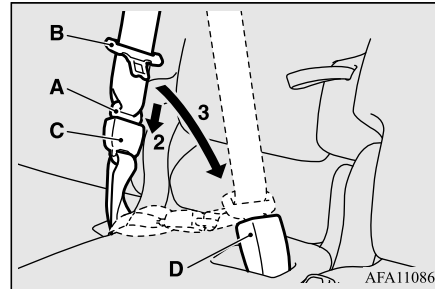

4. Pull the belt slightly to adjust slackness as desired.

To unfasten

1. Hold the latch plate (B) and push the button on the buckle (D).

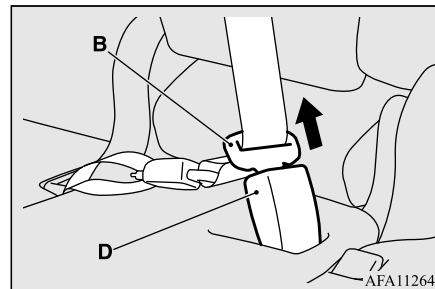

2. To release the buckle (C), press the button (E) with a narrow-tipped object (latch plate (B), mechanical key, etc.).

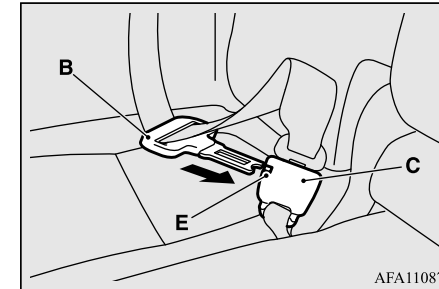

⚠ CAUTION

- As the belt retracts automatically, keep the latch plate held while retracting so that the belt stows slowly. Failure to do this could cause personal injury or damage to the vehicle.

3. After the seat belt is retracted completely, insert the latch plate (B) into the upper slit (F), and then insert the small latch plate (A) into the lower slit (G).

4

Pregnant women restraint

4

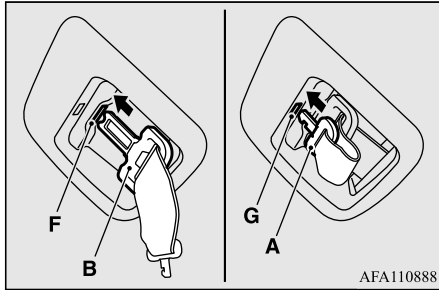

4. Store the seat belt buckle in the storage pocket.
Refer to “Second and third seat belt storage” on page 4-14.

Second and third seat belt storage

E00405301710

Seat belt plate storage

Outboard seating position

Pass the belt through the notch (A).

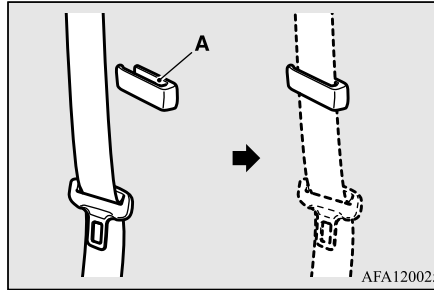

Second-centre seating position

Refer to “Second-centre 3-point type seat belt” on page 4-13.

Seat belt buckle storage

Store the seat belt buckles in the storage pockets.

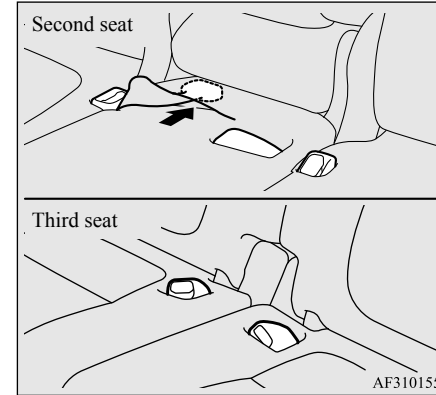

Pregnant women restraint

E00405601250

⚠ WARNING

- Seat belts work for everyone, including pregnant women. Pregnant women should use the available seat belts. This will reduce the likelihood of injury to both the woman and the unborn child. The lap belt should be worn across the thighs and as snug against the hips as possible, but not across the waist. Consult your doctor if you have any additional questions or concerns.

Seat belt pre-tensioner system

E00405701639

The driver's seat and front passenger's seat each have a seat belt equipped with a pre-tensioner system.

Pre-tensioner system

E00405802565

When the ignition switch or the operation mode is under the following conditions, if there is a frontal impact severe enough to injure the driver and/or front passenger, the pre-tensioner system will retract their respective seat belts instantaneously, thus maximizing the seat belt's effectiveness.

[Except for vehicles equipped with the keyless operation system]

The ignition switch is in the "ON" or "START" position.

[Vehicles equipped with the keyless operation system]

The operation mode is in ON.

WARNING

- To obtain the best results from your pre-tensioner seat belt, make sure you have adjusted your seat correctly and wear your seat belt properly.

CAUTION

- Installation of audio equipment or repairs in the vicinity of the pre-tensioner seat belts or floor console must be performed in line with MITSUBISHI MOTORS guidelines. It is important to do so because the work could affect the pre-tensioner systems.
- If you need to scrap the vehicle, please consult an authorised MITSUBISHI MOTORS dealer. It is important to do so because unexpected activation of the pre-tensioner seat belts could cause injuries.

NOTE

- The pre-tensioner seat belts will be activated if the vehicle suffers a severe impact, even if the seat belts are not worn.
- The pre-tensioner seat belts are designed to work only once. After the pre-tensioner seat belts have been activated, we recommend you have it replaced by an authorised MITSUBISHI MOTORS dealer.

SRS warning

E00405901442

The same warning lamp/display is shared by the SRS airbags and the pre-tensioner seat belts.

Refer to "SRS warning lamp/display" on page 4-27.

Child restraint

E00406404038

When transporting children in your vehicle, some type of child restraint system should always be used according to the size of the child. This is required by law in most countries.

The regulations concerning driving with children in the front seat may differ from country to country. You are advised to comply with the relevant regulations.

4

WARNING

- When possible, put children in the rear seat. Accident statistics indicate that children of all sizes and ages are safer when properly restrained in the rear seat rather than in the front seat.
- Holding a child in your arms is no substitute for a restraint system. Failure to use a proper restraint system can result in severe or fatal injury to your child.
- Each child restraint device or fixing is to be used only by one child.
- When attaching a child restraint system to the second seat, prevent the front seat-backs from touching the child's feet and child restraint system. Otherwise, the child could be seriously injured in the event of hard braking or a collision.

Child restraint

Caution for installing the child restraint on vehicle with front passenger's airbag

4

The label shown here is attached on vehicles with front passenger's airbag.



WARNING

● **Extreme Hazard!**

NEVER use a rearward facing child restraint on a seat protected by an ACTIVE AIRBAG in front of it, DEATH or SERIOUS INJURY to the CHILD can occur.

WARNING

- A REARWARD FACING CHILD RESTRAINT must NOT be used in the front passenger seat as it places an infant too close to the passenger's airbag. The force of an inflating airbag could kill or cause serious injuries to the child. A rearward facing child restraint must only be used in the rear seat.



- A FORWARD FACING CHILD RESTRAINT should be used in the rear seat whenever possible; if used in the front seat, adjust the seat to the most rearward position.

Infants and small children

E00406602401

When transporting infants and small children in your vehicle, follow the instruction given below.

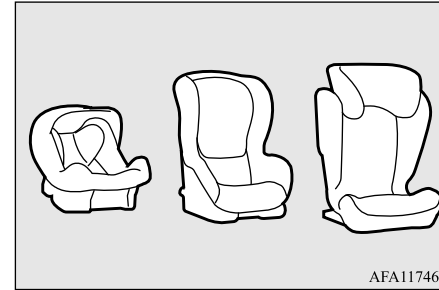

Instruction:

- For small infants, an infant carrier should be used. For small children whose height when seated allows the shoulder belt to lie in contact with the face or the throat, a child seat should be used.
- The child restraint system should be appropriate for your child's weight and height and properly fit the vehicle. For a higher degree of safety: THE CHILD RESTRAINT SYSTEM SHOULD BE INSTALLED IN THE REAR SEAT.
- Before purchasing a child restraint system, try installing it in the rear seat to make sure there is a good fit. Because of the location of the seat belt buckles and the shape of the seat cushion, it may be difficult to securely install some manufacturer's child restraint systems.

If the child restraint system can be pulled forward or to either side easily on the seat cushion after the seat belt has been tightened, choose another manufacturer's child restraint system.

WARNING

- **When installing a child restraint system, refer to the instructions provided by the manufacturer of the restraint system. Failure to do so can result in severe or fatal injury to your child.**
- **After installation, push and pull the child restraint system back and forth, and side to side, to see that it is positively secured. If the child restraint system is not installed securely, it may cause injury to the child or other occupants in the case of accident or sudden stops.**
- **When the child restraint system is not in use, keep your child restraint system secured with the seat belt or remove it from the vehicle in order to prevent it from being thrown around inside the vehicle during an accident.**

NOTE

- Depending on the seating position in the vehicle and the child restraint system that you have, the child restraint can be attached using one of the following two ways:

NOTE

- Using the lower anchorage in the second seat **ONLY** if the child restraint has ISOFIX mountings.
Refer to “Installing a child restraint system to the lower anchorage (ISOFIX child restraint mountings) and tether anchorage” on page 4-19.
- Using the seat belt.
Refer to “Installing a child restraint system to a 3-point type seat belt (with emergency locking mechanism)” on page 4-21.

Older children

E00406701450

Children who have outgrown the child restraint system should be seated in the rear seat and wear combination lap shoulder belt. The lap portion of the belt should be snug and positioned low on the abdomen so that it is below the top of the hip-bone. Otherwise, the belt could intrude into the child's abdomen during an accident and cause injury.





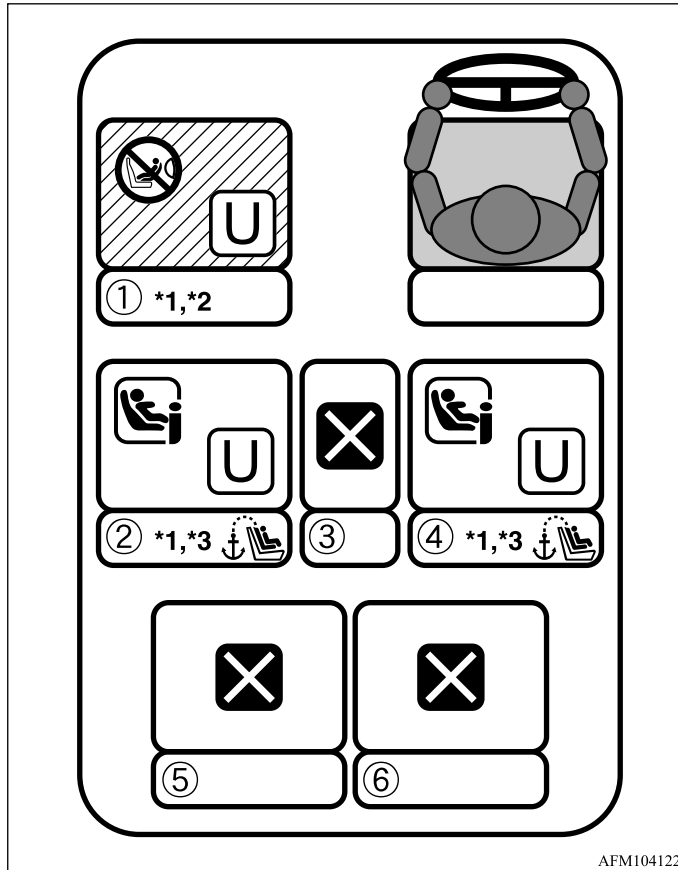

Selecting the child restraint system for each seating position

E00406803703

4



AFM104122

-  Suitable for “universal” category child restraint systems
-  Suitable for i-Size and ISOFIX child restraint systems
-  Suitable for front-facing child restraint systems only
-  Rear-facing child restraint systems must not be installed
-  Not suitable for a child restraint system
-  This seat is equipped with a top tether anchor

- *1: When installing a child restraint system, remove the head restraint from the seat and move the seat to the rearmost position. However, do not remove the head restraint when installing a booster cushion (see page 4-19, 4-21).
- *2: When installing a child restraint system on the front passenger seat, adjust the seatback angle to 5 steps rearward from the most upright position.
- *3: When installing a child restraint system on a second row outboard seat, adjust the seatback angle to 2 steps rearward from the most upright position.

⚠ CAUTION

- When installing a child restraint system on a second seat, slide the seat in front of the child restraint system forward or adjust its seatback so that the child's feet and the child restraint system do not contact the seat.

4

Category	Seating Position					
	①	②	③	④	⑤	⑥
	Front passenger	Second row (left)	Second row (centre)	Second row (right)	Third row (left)	Third row (right)
Seat compatible with a “universal” category child restraint system that is secured using the vehicle’s seat belts	Yes (front-facing only)	Yes	No	Yes	No	No
Seat compatible with i-Size and ISOFIX child restraint systems	No	Yes	No	Yes	No	No
Seat compatible with a side-facing child restraint system (L1/L2)	No	No	No	No	No	No
Maximum allowable size for a rear-facing child restraint system (R1/R2X/R2/R3)	No	R3	No	R3	No	No
Maximum allowable size for a front-facing child restraint system (F1/F2X/F2/F3)	No	F3	No	F3	No	No

Installing a child restraint system to the lower anchorage (ISOFIX child restraint mountings) and tether anchorage

E00406902358

Lower anchorage location

Your vehicle’s second seat is fitted with lower anchorages for attaching a child restraint system with ISOFIX mountings.

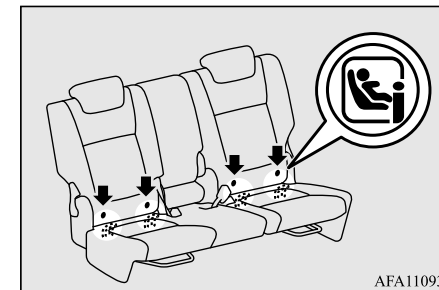

Child restraint

Tether anchorage location

There are two child restraint anchorage points located on the back of the second seatbacks. These are for securing a child restraint system tether strap to each of the two rear seating positions in your vehicle.

4

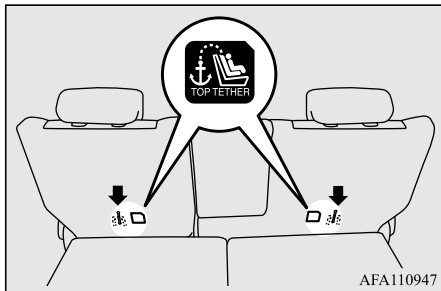

WARNING

- Child restraint anchorages are designed to withstand only those loads imposed by correctly fitted child restraints. Under no circumstances are they to be used for adult seatbelts, harnesses or for attaching other items or equipment to the vehicle.

Child restraint system with ISO-FIX mountings

The child restraint system is designed only for seats that incorporate lower anchorages. Retain the child restraint system using the lower anchorages.

It is not necessary to retain the child restraint system using the vehicle's seatbelts.

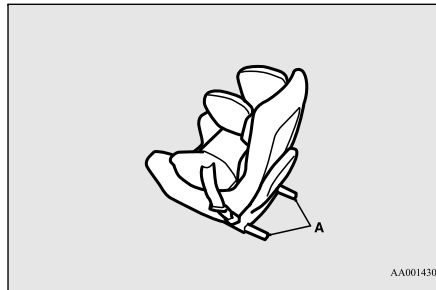

A: Child restraint system connectors

To install

1. Remove any foreign material in or around the connectors and ensure the vehicle seat belt is in its normal storage position.
2. Remove the head restraint from the location in which you wish to install a child restraint system.

Refer to "Head restraints" on page 4-7.

CAUTION

- Do not remove the head restraint when installing a booster cushion.

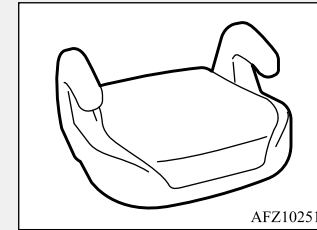

3. When installing a child restraint system, slide the seat to its most rearward position.
4. Open the gap a little with your hand to expose the lower anchorages (A).
5. Push the child restraint system's connectors (B) into the lower anchorages (A) in accordance with the instructions provided by the child restraint system's manufacturer.

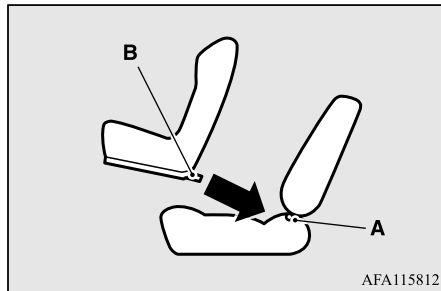

A: Lower anchorage
B: Connector

If your child restraint system has a support leg, make sure that there is a support leg at the stable position on the floor.

If your child restraint system requires the use of a tether strap, fasten the tether strap in accordance with step 6.

- Latch the tether strap hook (C) of the child restraint system to the tether anchor bar (D) and tighten the top tether strap hook so it is securely fastened.

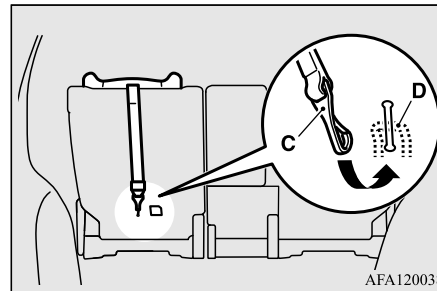

- Push and pull the child restraint system in all directions to be sure it is secure.

To remove

Remove the child restraint system in accordance with the instructions provided by the child restraint system's manufacturer.

Installing a child restraint system to a 3-point type seat belt (with emergency locking mechanism)

E00408702015

4

To install

- Put a child restraint system on the seat in which you wish to install it, and remove the head restraint from the seat. Refer to "Head restraints" on page 4-7.

CAUTION

- Do not remove the head restraint when installing a booster cushion.

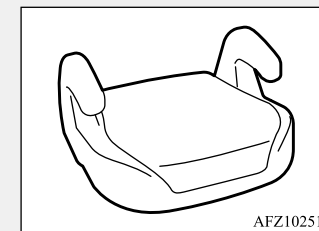

- When installing a child restraint system, adjust seat slide to its most rearward position.

Seat belt inspection

4

3. Route the belt through the child restraint according to the child restraint system manufacturer's instructions, then insert the latch plate into the buckle.
4. Remove all slack of a lap belt by pulling the webbing through the belt's adjustment feature.
3-point type seat belt requires no length adjustment, remove all slack by using the locking clip.

⚠ WARNING

- For some types of child restraint, the locking clip (A) should be used to help avoid personal injury during a collision or sudden manoeuvre. It must be fitted and used in accordance with the child restraint manufacturer's instructions. The locking clip must be removed when the child restraint is removed.

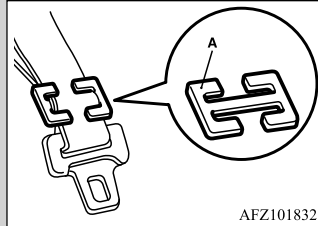

5. Before putting the child in the restraint, push and pull the restraint in all directions to be sure it is secure. Do this before each use.

To remove

Remove the plate from the buckle, then remove the seat belt from the child restraint system.

Seat belt inspection

E00406302017

Check the belts for cuts, worn or frayed webbing and for cracked or deformed metallic parts. Replace the belt assembly if defective.

⚠ WARNING

- We recommend you to have all seat belt assemblies including retractors and attaching hardware inspected after any collision. We recommend that seat belt assemblies in use during a collision be replaced unless the collision was minor and the belts show no damage and continue to operate properly.

⚠ WARNING

- Do not attempt to repair or replace any part of the seat belt assemblies; we recommend you to have this work done by an authorised MITSUBISHI MOTORS dealer. Incorrect repair or replacement could reduce the effectiveness of the belts and could result in serious injury in the event of a collision.
- Once the pre-tensioner has activated, it cannot be re-used. It must be replaced together with the retractor.
- Do not insert any foreign objects (pieces of plastic, paper clips, buttons, etc.) in the buckle or retractor mechanism. In addition, do not modify, remove, or install the seat belt. Otherwise, the seat belt may not be able to provide adequate protection in a collision or other situation.

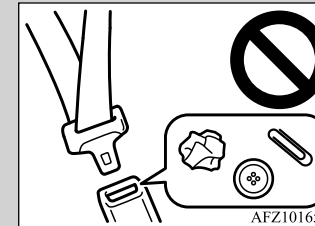

- A dirty belt should be cleaned with neutral detergent in warm water. After rinsing in water, let it dry in the shade. Do not attempt to bleach or re-dye the belts because this affects their characteristics.

Supplemental restraint system (SRS) - airbag

E00407203690

The information written in this supplemental restraint system (SRS) section contains important points concerning the driver's and front passenger's airbags.

The SRS airbags are designed to supplement the primary protection of the driver and front passenger side seat belt systems by providing those occupants with protection against head and chest injuries in certain moderate-to-severe frontal collisions.

The SRS is NOT a substitute for the seat belts; for maximum protection in all types of crashes and accidents, seat belts should ALWAYS be worn by everyone who drives or rides in this vehicle.

How the supplemental restraint system works

E00407303721

The SRS includes the following components:

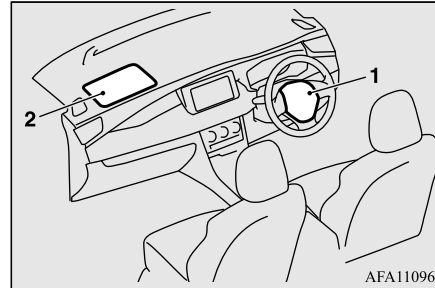

- 1- Airbag module (Driver)
- 2- Airbag module (Passenger)

Only when the ignition switch or the operation mode is under the following conditions, the airbags will operate.

[Except for vehicles equipped with the keyless operation system]

The ignition switch is in the "ON" or "START" position.

[Vehicles equipped with the keyless operation system]

The operation mode is in ON.

The airbags deployment produces a sudden, loud noise, and releases some smoke and powder, but these conditions are not injurious, and do not indicate a fire in the vehicle. People with respiratory problems may feel some temporary irritation from chemicals used to produce the deployment; open the

windows after airbag deployment, if safe to do so.

The airbags deflate very rapidly after deployment, so there is little danger of obscured vision.

CAUTION

- Airbags inflate at an extremely rapid speed. In certain situations, contact with inflating airbags can result in abrasions, light cuts, bruises, and the like.

WARNING

- **IT IS VERY IMPORTANT TO BE PROPERLY SEATED.**
A driver or front passenger too close to the steering wheel or instrument panel during airbag deployment can be killed or seriously injured.
Airbags inflate very fast, and with great force.
If the driver and front passenger are not properly seated and restrained, the airbags may not protect you properly, and could cause serious or fatal injuries when it inflates.
- Do not sit on the edge of the seat or lean head or chest close to the steering wheel or instrument panel. Do not put feet or legs on or against the instrument panel.

4

Supplemental restraint system (SRS) - airbag

4

⚠ WARNING

- Place all infants and small children in the rear seat and properly restrained using an appropriate child restraint system. The rear seat is the safest for infants and children.

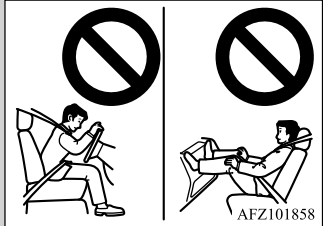

- Infants and small children should never be unrestrained, stand up against the instrument panel or held in your arms or on your lap. They could be seriously injured or killed in a collision, including when the airbag inflates. They should be properly seated in the rear seat in an appropriate child restraint system. See the “Child restraint” section of this owner’s manual.

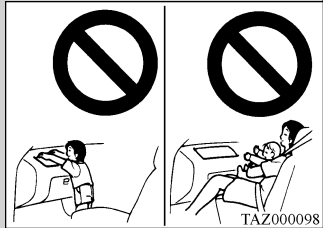

⚠ WARNING

- Older children should be seated in the rear seat, properly wearing the seat belt, with an appropriate booster seat if needed.

Caution for installing the child restraint on vehicle with front passenger’s airbag

E00408802638

The label shown here is attached on vehicles with front passenger’s airbag.



⚠ WARNING

- **Extreme Hazard!**
NEVER use a rearward facing child restraint on a seat protected by an **ACTIVE AIRBAG** in front of it, **DEATH** or **SERIOUS INJURY** to the **CHILD** can occur.

Driver’s and passenger’s front airbag system

E00407402161

The driver’s airbag is located under the padded cover in the middle of the steering wheel. The front passenger’s airbag is contained in the instrument panel above the glove box. The front passenger’s airbag deploys at the same time as the driver’s airbag, even if the passenger seat is not occupied.

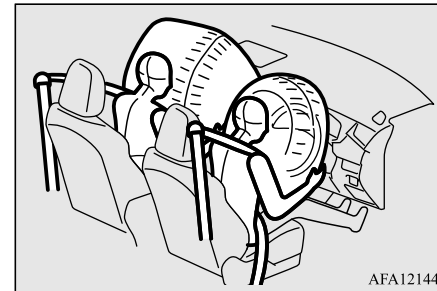

Deployment of front airbags

E00412501453

The front airbags ARE DESIGNED TO DEPLOY when...

The front airbags are designed to deploy when the vehicle suffers a moderate to severe frontal impact. A typical condition is shown in the illustration.

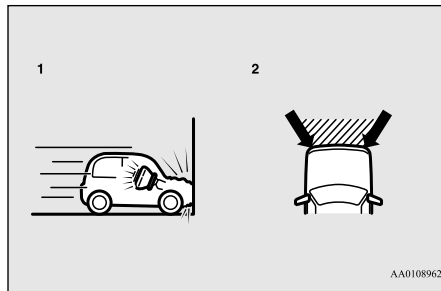

- 1- Head-on collision with a solid wall at speed of approximately 25 km/h or higher
- 2- Moderate to severe frontal impact within the shaded area between the arrows

The front airbags will deploy if the severity of impact is above the designed threshold level, comparable to an approximately

25 km/h collision when impacting straight into a solid wall that does not move or deform. If the severity of the impact is below the above threshold level, the front airbags may not deploy. However, this threshold speed will be considerably higher if the vehicle strikes an object that absorbs the impact by either deforming or moving (for example, another stationary vehicle, pole or a guard rail).

Because frontal collisions can easily move you out of position, it is important to always properly wear your seat belts. Your seat belts will help keep you in a safe distance from the steering wheel and instrument panel during the initial stages of airbag deployment. The initial stage of airbag inflation is the most forceful, and can possibly cause serious or fatal injuries. Moreover, the seat belts in your vehicle are your primary means of protection in a collision. The SRS airbags are designed to provide additional protection. Therefore, for your safety and the safety of all occupants, be sure to always properly wear your seat belts.

The front airbags MAY NOT DEPLOY when...

With certain types of frontal collisions, the vehicle's body structure is designed to absorb the shock to help protect the occupants from

harm. (The vehicle body's front area may deform significantly as it absorbs the impact.) Under such circumstances, the front airbags may not deploy irrespective of the deformation and damage to the vehicle body. Examples of some typical conditions are shown in the illustration.

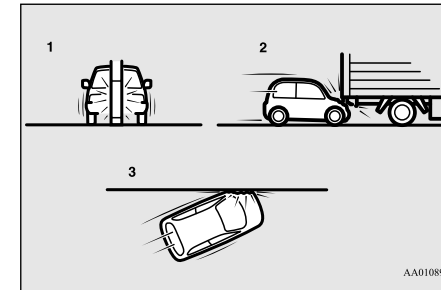

- 1- Collision with a utility pole, tree or other narrow objects
- 2- Vehicle slides under the rear body of a truck
- 3- Oblique frontal impacts

Because the front airbags do not protect the occupant in all types of frontal collisions, be sure to always properly wear your seat belts.

The front airbags ARE NOT DESIGNED TO DEPLOY when...

4

The front airbags are not designed to deploy in conditions where they cannot typically provide protection to the occupant. Such conditions are shown in the illustration.

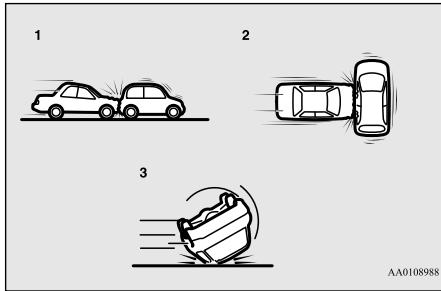

- 1- Rear end collisions
- 2- Side collisions
- 3- Vehicle rolls onto its side or roof

Because the front airbags do not protect the occupant in all types of collisions, be sure to always properly wear your seat belts.

The front airbags MAY DEPLOY when...

The front airbags may deploy if the bottom of the vehicle suffers a moderate to severe impact (undercarriage damage). Examples of some typical conditions are shown in the illustration.

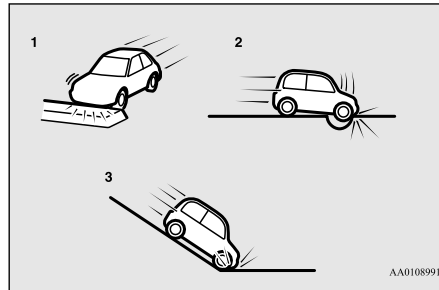

- 1- Collision with an elevated median/island or kerb
- 2- Vehicle travels over a deep hole/pot-hole
- 3- Vehicle drives down a steep slope and hits the ground

Because the front airbags may deploy in certain types of unexpected impacts as shown in the illustration that can easily move you out of position, it is important to always properly wear your seat belts. Your seat belts will help

keep you in a safe distance from the steering wheel and instrument panel during the initial stages of airbag deployment. The initial stage of airbag inflation is the most forceful and can possibly cause serious or fatal injuries if you contact it at this stage.

WARNING

- Do not attach anything to the steering wheel padded cover, such as trim material, badges, etc. It might strike and injure an occupant if the airbag inflates.
- Do not set anything on, or attach anything to, the instrument panel above the glove box. It might strike and injure an occupant if the airbag inflates.

AFZ101845

- Do not attach accessories to, or put them in front of, the windscreen. These objects could restrict the airbag inflation, or strike and injure an occupant if the airbags inflate.

⚠ WARNING

- Do not put packages, pets or other objects between the airbags and the driver or front passenger. It could affect airbag performance, or could cause injury when the airbag inflates.
- Right after the airbag inflation, several airbag system components will be hot. Do not touch them; you could be burned.
- The airbag system is designed to work only once. Once the airbags have deployed, they will not work again. They must promptly be replaced and the entire airbag system must be inspected by an authorised MITSUBISHI MOTORS dealer.

SRS warning lamp/display*

E00407803234

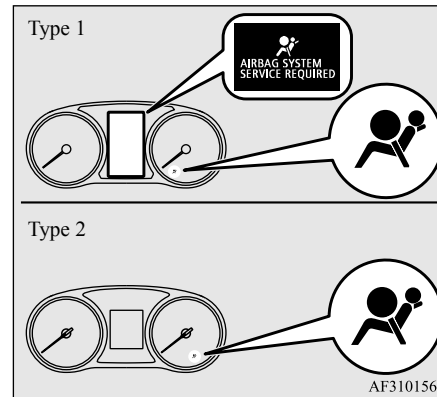

There is a supplemental restraint system (“SRS”) warning lamp on the instrument panel. The system checks itself every time the ignition switch is turned to the “ON” position or the operation mode is put in ON. The SRS warning lamp will come on for several seconds and then go out. This in normal and means the system is working properly. If there is a problem involving one or more of the SRS components, the warning lamp will come on and stay on. At the same time, the warning display will appear on the information screen in the multi-information display (Type 1 only).

The SRS warning lamp/display is shared by the SRS airbag and the seat belt pre-tensioner system.

⚠ WARNING

- If any of the following conditions occur, there may be a problem with the SRS airbags and/or seat belt pre-tensioners, and they may not function properly in a collision or may suddenly activate without a collision:
 - Even when the ignition switch or the operation mode is in ON, the SRS warning lamp does not come on or it remains on.
 - The SRS warning lamp and/or the warning display comes on while driving.

The SRS airbags and seat belt pre-tensioners are designed to help reduce the risk of serious injury or death in certain collisions. If either of the above conditions occurs, immediately have your vehicle checked by an authorised MITSUBISHI MOTORS dealer.

4

SRS servicing

E00407902951

4

WARNING

- Any maintenance performed on or near the components of the SRS must be performed only by an authorised MITSUBISHI MOTORS dealer. Do not permit anyone else to do service, inspection, maintenance or repair on any SRS components or wiring; similarly, no part of the SRS should ever be handled or disposed of by anyone except an authorised MITSUBISHI MOTORS dealer.

Improper work on the SRS components or wiring could result in inadvertent deployment of the airbags, or could render the SRS inoperative; either situation could result in serious injury.

- Do not modify your steering wheel, seat belt retractor or any other SRS components. For example, replacement of the steering wheel, or modifications to the front bumper or body structure can adversely affect SRS performance and lead to possible injury.
- If your vehicle has received any damage, you should have the SRS inspected by an authorised MITSUBISHI MOTORS dealer to ensure it is in proper working order.

WARNING

- If you found any tear scratch, crack or damage to the portion of the airbags, you should have the SRS inspected by an authorised MITSUBISHI MOTORS dealer.

NOTE

- If your vehicle has to be scrapped, do this in line with local legislation and contact an authorised MITSUBISHI MOTORS dealer to safely dismantle the airbag system.

Instruments and controls

Instruments	5-2
Multi-information display - Type 1	5-3
Multi-information display - Type 2	5-16
Indicator lamp, warning lamp, and information screen display list (multi-information display - Type 1)	5-23
Indicator and warning lamps (multi-information display - Type 2)	5-33
Indicator lamps	5-33
Warning lamps	5-34
Information screen display (vehicle equipped with the multi-information display - Type 1)	5-36
Combination headlamps and dipper switch	5-38
Turn-signal lever	5-40
Hazard warning flasher switch	5-41
Front fog lamp switch*	5-41
Wiper and washer switch	5-42
Rear window demister switch	5-44
Horn switch	5-45

Instruments

E00500103255

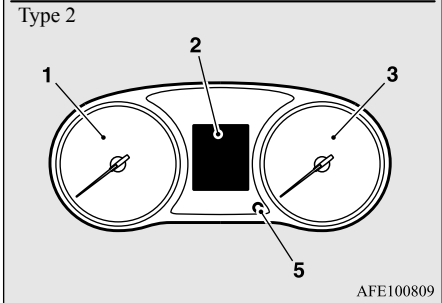
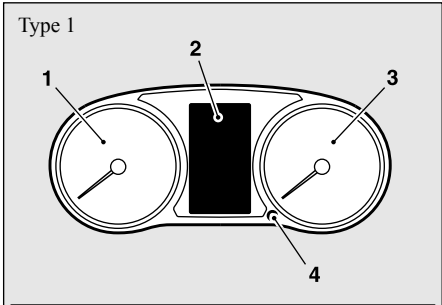

AFE100809

1- Tachometer

The tachometer indicates the engine speed (r/min). The tachometer can help you obtain more economical driving and also warns you of excessive engine speeds (Red zone).

- 2- Multi-information display (Type 1: TFT colour LCD) → P.5-3
Information screen display (Type 1) → P.5-24
Multi-information display (Type 2: mono-tone LCD) → P.5-16
- 3- Speedometer (km/h)
- 4- Rheostat illumination button (Type 1) → P.5-2
- 5- Multi-information display switch (Type 2) → P.5-17

CAUTION

- When driving, watch the tachometer to make sure that the engine speed indication does not rise into the red zone (excessive engine r/min).

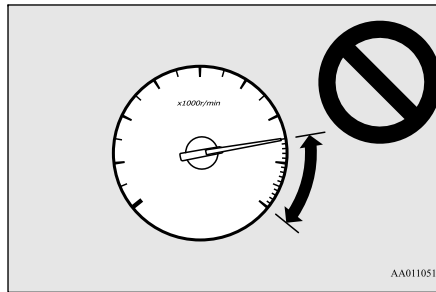

Meter illumination control - Type 1

E00531301288

Each time you press the rheostat illumination button, there is a sound and the brightness of the instruments changes.

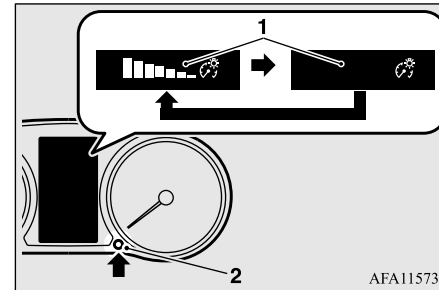

- 1- Brightness level
- 2- Rheostat illumination button

NOTE

- You can adjust to 8 different levels respectively for when the position lamps are illuminated and when they are not.
- The brightness level of the instruments is stored when the operation mode is put in OFF.

Multi-information display - Type 1

NOTE

- If you press and hold the button for approximately 2 seconds or more when the position lamps are illuminated, the brightness level changes to the maximum level. Pressing and holding the button for approximately 2 seconds or more again returns the brightness level to the previous level.

Multi-information display - Type 1

E00519903608



Always stop the vehicle in a safe place before operating.

The following information is included on the multi-information display: warnings, odometer, tripmeter, average and momentary fuel consumption, average speed etc.

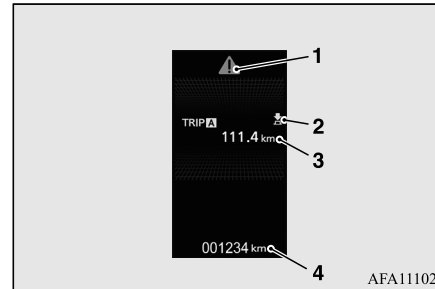
[When the operation mode is OFF]





AFA111029

- 1-  mark display → P.5-6
- 2- “” or “” mark indicator → P.5-5
- 3- Information screen → P.5-4
Interrupt display screen → P.5-5
- 4- Odometer → P.5-7

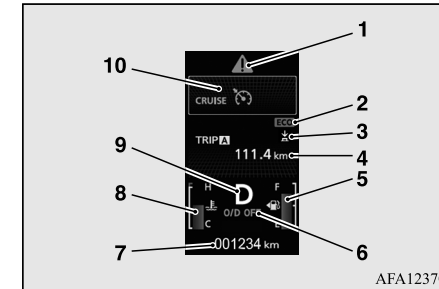
[When the operation mode is ON]



AFA123707

- 1-  mark display → P.5-6
- 2- ECO indicator → P.5-11
- 3- “” or “” mark indicator → P.5-5
- 4- Information screen → P.5-5
- 5- Fuel remaining display → P.5-6
- 6- Overdrive OFF indicator → P.6-22
- 7- Odometer → P.5-7
- 8- Engine coolant temperature display → P.5-6
- 9- Selector lever position indicator display → P.6-20
- 10- Cruise control indicator display* → P.6-34

5

NOTE

- The fuel units, display language, and other settings can be changed. Refer to “Changing the function settings” on page 5-12.

Multi-information display - Type 1

Multi-information display switch

E00520002077

Each time the multi-information display switch is operated, the buzzer sounds and the multi-information display changes between information such as warnings, tripmeter, average and momentary fuel consumption, distance range etc.

It is also possible to change elements such as the language and units used on the multi-information display by operating the multi-information display switch.

5

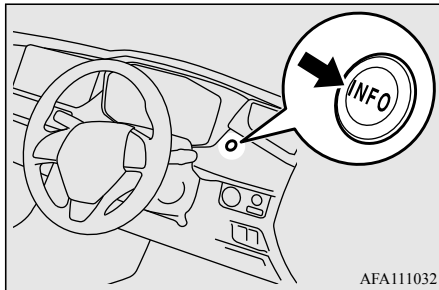

Information screen (when the operation mode is OFF)

E00520202082

Each time you lightly press the multi-information display switch, the display screen switches in the following order.

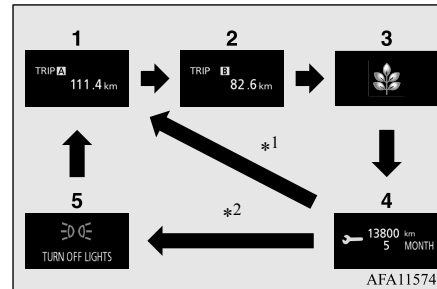

- *1: When there is no warning display
- *2: When there is a warning display
- 1- Tripmeter **A** → P.5-7
- 2- Tripmeter **B** → P.5-7
- 3- ECO score display → P.5-11
- 4- Service reminder → P.5-8
- 5- Redisplay of a warning display screen → P.5-5

Information screen (when the operation mode is changed from OFF to ON)

E00520702276

When the operation mode is put in ON, the display screen switches in the following order.

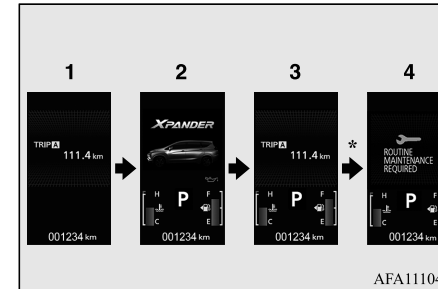

- *: When the inspection time has arrived
- 1- Screen when the operation mode is OFF
- 2- System check screen → P.5-9
- 3- Screen when the operation mode is ON
- 4- Service reminder → P.5-8

Information screen (when the operation mode is ON)

E00521102512

Each time you lightly press the multi-information display switch, the display screen switches in the following order.

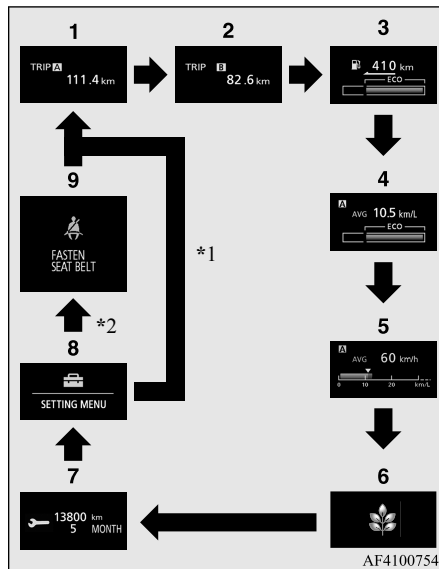

*1: When there is no warning display

*2: When there is a warning display

1- Tripmeter **A** → P.5-7

2- Tripmeter **B** → P.5-7

- 3- Driving range display → P.5-9
ECO drive assist display → P.5-11
- 4- Average fuel consumption display → P.5-10
ECO drive assist display → P.5-11
- 5- Average speed display → P.5-10
Momentary fuel consumption display → P.5-10
- 6- ECO score display → P.5-11
- 7- Service reminder → P.5-8
- 8- Function setting screen → P.5-12
- 9- Redisplay of a warning display screen → P.5-5

NOTE

- While driving, the service reminder are not displayed even if you operate the multi-information display switch. Always stop the vehicle in a safe place before operating.
- While driving, the function setting screen is not displayed even if you operate the multi-information display switch. Always stop the vehicle in a safe place before operating and firmly apply the parking brake and put the selector lever into the "P" (PARK) position. Refer to "Changing the function settings" on page 5-12.
- When there is information to be announced, such as a system fault, the buzzer sounds and the screen display is switched. Refer to "Interrupt display screen" on page 5-5.

Interrupt display screen

E00522002042

Warning display

When there is information to be announced, such as a system fault, the buzzer sounds and the information screen is switched to the warning display screen.

Refer to the warning list and take the necessary measures.

Refer to "Warning display list" on page 5-25. When the cause of the warning display is eliminated, the warning display goes out automatically.

5

To return to the screen displayed before the warning display

Even if the cause of the warning display is not eliminated, you can return to the screen that was displayed before the warning display.

If you press the multi-information display switch, the display screen switches to the screen that was displayed before the warning display and the **A** mark (A) is displayed.

Multi-information display - Type 1

5

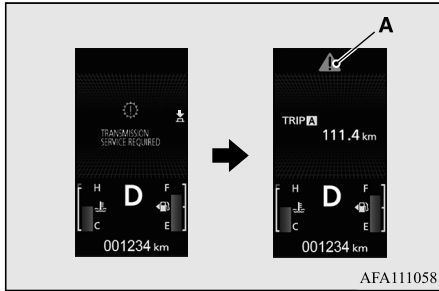

If you want to switch the display

Warning display screens with a “” or “” mark indicator displayed in the upper right of the screen can be switched. If you want to switch the display, press the multi-information display switch as follows.

“” : Press lightly.

“” : Press for approximately 2 seconds or more.

Redisplay of a warning display screen

When the mark is displayed, if you lightly press the multi-information display switch a few times, the warning display screen you switched from is redisplayed.

Other interrupt displays

The operation status of each system is displayed on the information screen. Refer to the appropriate page in the warning display list for further details. Refer to “Other interrupt displays” on page 5-31.

mark display

This is displayed when you press the multi-information display switch and return from the warning display screen to the previous screen.

This mark is also displayed if there is another warning other than the one displayed.

When the cause of the warning display is eliminated, the mark goes out automatically.

NOTE

- When the mark is displayed, the warning display screen can be redisplayed on the information screen. Refer to “Information screen (when the operation mode is OFF)” on page 5-4. Refer to “Information screen (when the operation mode is ON)” on page 5-5.

Engine coolant temperature display

E00533801203

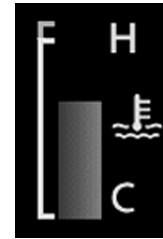

This indicates the engine coolant temperature.

If the coolant becomes hot, “” will blink. Pay careful attention to the engine coolant temperature display while you are driving.

CAUTION

- If the engine is overheating, “” will blink. In this case, the bar graph is on the red zone. Immediately park the vehicle in a safe place and take the required measures. Refer to “Engine overheating” on page 8-3.

Fuel remaining display

E00522201962

This displays the amount of fuel remaining.

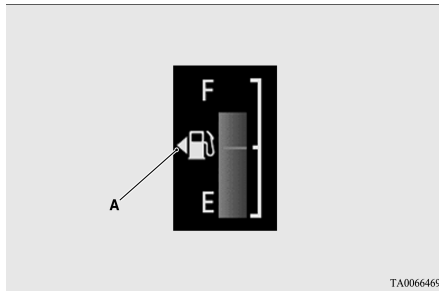

F- Full
E- Empty

TA0066469

NOTE

- It may take several seconds to stabilise the display after refilling the tank.
- If fuel is added with the operation mode is in ON, the fuel gauge may incorrectly indicate the fuel level.
- The arrow (A) indicates that the fuel tank filler is located on the left side of the body.

Fuel remaining warning display

E00522402408

When the fuel is reduced to approximately 8 litres, the information screen switches to the interrupt display of the fuel remaining warning display, and the “” mark (B) on the fuel remaining display flashes slowly (approximately once per second). After a few seconds,

the information screen returns from the fuel remaining warning display to the previous screen. If the warning display appears, refuel as soon as possible.

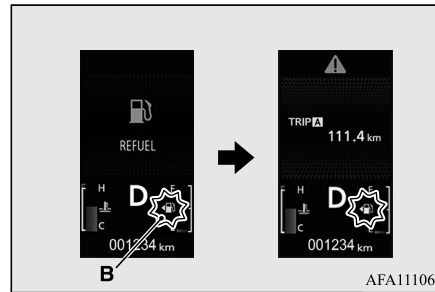

AFA111061

CAUTION

- Do not run out of fuel, or the catalytic converter may be adversely affected. If the warning display appears, refuel as soon as possible.
- If the fuel tank is almost empty, the “” mark (B) on the fuel remaining display flashes quickly (approximately twice per second). Refuel as soon as possible.

NOTE

- On inclines or curves, the display may be incorrect due to the movement of fuel in the tank.

Odometer

E00527801178

The odometer indicates the distance travelled.

Tripmeter

E00527901209

The tripmeter indicates the distance travelled between two points.

5

Example usage of tripmeter **A** and tripmeter **B**

It is possible to measure two currently travelled distances, from home using tripmeter **A** and from a particular point on the way using tripmeter **B**.

To reset the tripmeter

To return the display to 0, hold down the multi-information display switch for approximately 2 seconds or more. Only the currently displayed value will be reset.

Example

If tripmeter **A** is displayed, only tripmeter **A** will be reset.

Multi-information display - Type 1

NOTE

- When disconnecting the battery terminal, the memory of tripmeter **A** and **B** are cleared, and the display returns to "0".

5

Service reminder

E00522502366

Displays the approximate time until the next periodic inspection recommended by MITSUBISHI MOTORS. "---" is displayed when the inspection time has arrived.

NOTE

- Depending on the vehicle specifications, the displayed time may differ from the next periodic inspection time recommended by MITSUBISHI MOTORS. In addition, the display settings for the next periodic inspection time can be modified. To modify the display settings, have it adjusted at an authorised MITSUBISHI MOTORS dealer. For more details, consult an authorised MITSUBISHI MOTORS dealer.

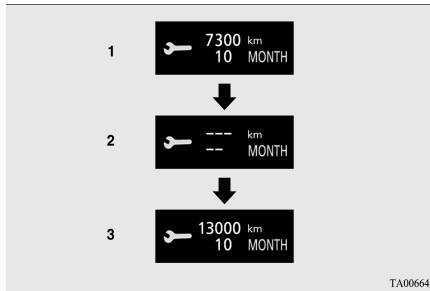

TA00066485

1. Displays the time until the next periodic inspection.

NOTE

- The distance is shown in units of 100 km (100 miles). The time is shown in units of months.

2. This informs you that a periodic inspection is due. Please consult an authorised MITSUBISHI MOTORS dealer.

At that time, when the operation mode is changed from OFF to ON, the warning display is displayed for a few seconds on the information screen.



3. After your vehicle is inspected at an authorised MITSUBISHI MOTORS dealer, it displays the time until the next periodic inspection.

To reset

The "---" display can be reset while the operation mode is in OFF. When the display is reset, the time until the next periodic inspection is displayed and the warning display is no longer displayed when the operation mode is changed from OFF to ON.

1. When you lightly press the multi-information display switch a few times, the information screen switches to the service reminder display screen.

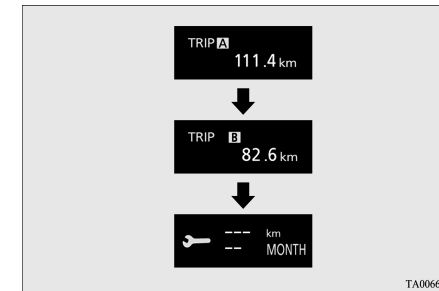

- Press and hold the multi-information display switch for approximately 2 seconds or more to display “” and make it flash. (If there is no operation for approximately 10 seconds with flashing, the display returns to the previous screen.)
- Lightly press the multi-information display switch while the icon is flashing to change the display from “---” to “CLEAR”. After this, the time until the next periodic inspection will be displayed.

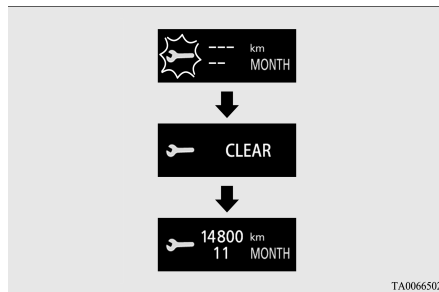

CAUTION

- The customer is responsible for making sure that periodic inspection and maintenance are performed. Inspections and maintenance must be performed to prevent accidents and malfunctions.

NOTE

- “---” display cannot be reset when the operation mode is in ON.
- When “---” is displayed, after a certain distance and a certain period of time, the display is reset and the time until the next periodic inspection is displayed.
- If you accidentally reset the display, we recommend you to consult an authorised MITSUBISHI MOTORS dealer.

System check screen

E00531001230

When the operation mode is put in ON, the system check screen is displayed for approximately 4 seconds. If there is no fault, information screen (when the operation mode is ON) is displayed.

If there is a fault, the screen changes to warning display.

Refer to “Warning display list” on page 5-25.

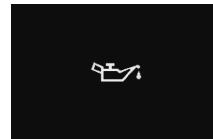

NOTE

- The system check screen display varies depending on the customer’s equipment.

Driving range display

E00538001170

This displays the approximate driving range (how many more kilometres or miles you can drive). When the driving range falls below approximately 50 km (30 miles), “---” is displayed.

Refuel as soon as possible.

5



NOTE

- The driving range is determined based on the fuel consumption data. This may vary depending on the driving conditions and habits. Treat the distance displayed as just a rough guideline.
- When you refuel, the driving range display is updated. However, if you only add a small amount of fuel, the correct value will not be displayed. Fill with a full tank whenever possible.
- On rare occasions, the value displayed for the driving range may change if you are parked on an extremely steep incline. This is due to the movement of fuel in the tank and does not indicate any malfunction.

Multi-information display - Type 1

NOTE

- The display setting can be changed to the preferred units (km or miles). Refer to “Changing the function settings” on page 5-12.

5

Average fuel consumption display

E00531201362

This displays the average fuel consumption from the last reset to the present time.

The reset mode conditions for the average fuel consumption display can be switched between “Auto reset” and “Manual reset”.

Refer to “Changing the reset mode for average fuel consumption and average speed” on page 5-12.

For information on how to change the average fuel consumption display setting, refer to “Changing the function settings” on page 5-12.

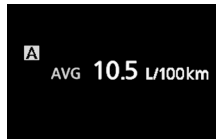

NOTE

- The average fuel consumption display can be reset separately for the auto reset mode and for the manual reset mode.

NOTE

- “---” is displayed when the average fuel consumption cannot be measured.
- The initial (default) setting is “Auto reset mode”.
- The average fuel consumption will depend on the driving conditions (road conditions, how you drive, etc.). The displayed fuel consumption may vary from the actual fuel consumption. Treat the fuel consumption displayed as just a rough guideline.
- The memory of the auto reset mode or manual reset mode for the average fuel consumption display is erased if the battery is disconnected.
- The display setting can be changed to the preferred units {km/L, mpg (US), mpg (UK) or L/100 km}. Refer to “Changing the function settings” on page 5-12.

Average speed display

E00533701228

This displays the average speed from the last reset to the present time.

The reset mode conditions for the average speed display can be switched between “Auto reset” and “Manual reset”.

Refer to “Changing the reset mode for average fuel consumption and average speed” on page 5-12.

For the method for changing the average speed display setting, refer to “Changing the function settings” on page 5-12.



NOTE

- The average speed display can be reset separately for the auto reset mode and for the manual reset mode.
- “---” is displayed when the average speed cannot be measured.
- The initial (default) setting is “Auto reset mode”.
- The display setting can be changed to the preferred units (km/h or mph). Refer to “Changing the function settings” on page 5-12.
- The memory of the auto reset mode or manual reset mode for the average speed display is erased if the battery is disconnected.

Momentary fuel consumption display

E00533601243

While driving, this displays the momentary fuel consumption, using a bar graph.

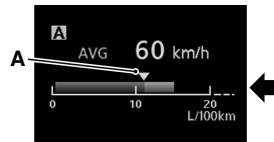

The “▼” mark (A) in the momentary fuel gauge shows the average fuel consumption. When the value of momentary fuel consumption surpasses the value of average fuel consumption, the momentary fuel consumption is displayed with a green bar graph.

Be conscious of maintaining the value of momentary fuel consumption below the value of average fuel consumption, it can help you drive with the better fuel consumption.

NOTE

- When the momentary fuel consumption cannot be measured, the bar graph is not displayed.
- The display setting can be changed to the preferred units {km/L, mpg (US), mpg (UK) or L/100 km}. Refer to “Changing the function settings” on page 5-12.
- It is possible to cancel the green bar graph. Refer to “Changing the function settings” on page 5-12.

ECO indicator

E00529301294



This indicator will be displayed when fuel-efficient driving is achieved.

ECO drive assist display

E00531501336

This function displays how fuel-efficiently you are driving under different driving conditions.

The ECO drive assist display will change as follows if you do fuel-efficient driving using the accelerator in a way well matched with the vehicle speed.

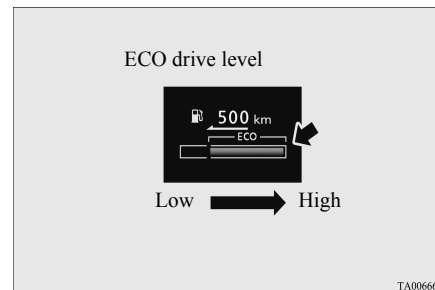

TA0066645

NOTE

- The ECO drive assist is displayed only when vehicle is driving with the selector lever in the “D” (DRIVE) position.

ECO score display

E00531601265

5

ECO score indicates the points you have scored on fuel-efficient driving by the number of leaves as follows:

[When the operation mode is ON]

The display shows the score you achieved in the last several minutes.

[When the operation mode is put in OFF]

The display shows the overall ECO score the function has counted from the time when the operation mode is set to “ON” to the time when it is set to “OFF”.

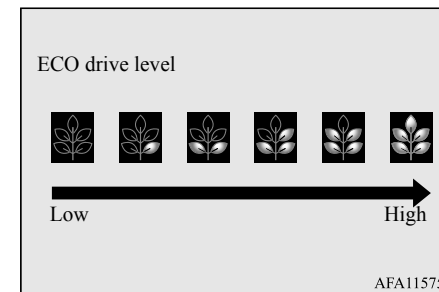

AFA115753

Multi-information display - Type 1

Changing the function settings

E00522702485

The “Display language”, “Fuel consumption unit”, and “Average fuel consumption and speed reset method” etc. setting can be modified as desired.

5

1. Stop the vehicle in a safe place.
Firmly apply the parking brake and put the selector lever into the “P” (PARK) position.
2. Lightly press the multi-information display switch a few times to switch the information screen to the function setting screen.
Refer to “Information screen (when the operation mode is ON)” on page 5-5.

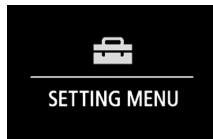

CAUTION

- For safety, stop the vehicle before operating. While driving, even if you operate the multi-information display switch, the function setting screen is not displayed.

3. Press and hold the multi-information display switch for approximately 2 seconds or more to switch from the setting mode screen to the menu screen.

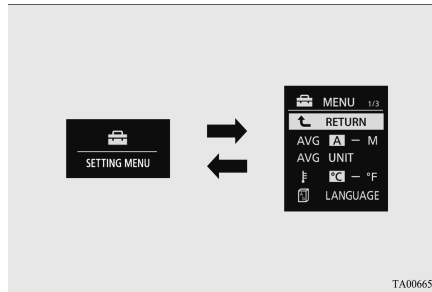

TA00066515

NOTE

- To return the menu screen to the function setting screen, press and hold the multi-information display switch for approximately 2 seconds or more.
- If no operations are made within approximately 30 seconds of the menu screen being displayed, the display returns to the function setting screen.

4. Select the item to change on the menu screen and change to the desired setting. Refer to the following items for further details on the operation methods.

Refer to “Changing the reset mode for average fuel consumption and average speed” on page 5-12.

Refer to “Changing the fuel consumption display unit” on page 5-13.

Refer to “Changing the display language” on page 5-14.

Refer to “Operation sound setting” on page 5-14.

Refer to “Changing the time until “REST REMINDER” is displayed” on page 5-14.

Refer to “Changing the turn-signal sound” on page 5-15.

Refer to “Changing the momentary fuel consumption display” on page 5-15.

Refer to “Returning to the factory settings” on page 5-15.

NOTE

- If the battery is disconnected, these function settings are reset from memory and is automatically to the factory settings.

Changing the reset mode for average fuel consumption and average speed

E00522902517

The mode conditions for the average fuel consumption and average speed display can be switched between “Auto reset” and “Manual reset”.

1. Press and hold the multi-information display switch for approximately 2 seconds or more to switch from the setting mode screen to the menu screen.

Refer to “Changing the function settings” on page 5-12.

2. Lightly press the multi-information display switch to select **AVG A – M** “AVG (average fuel consumption and average speed setting)”.
 3. Press and hold the multi-information display switch for approximately 2 seconds or more to switch from A/1 (Auto reset mode) to M/2/P (Manual reset mode), or from M/2/P to A/1.

The setting is changed to the selected mode condition.

Manual reset mode

- When the average fuel consumption and average speed are being displayed, if you hold down the multi-information display switch, the average fuel consumption and average speed displayed at that time are reset.
- When the operation mode from ACC or OFF to ON, the mode setting is automatically switched from manual to auto.

Switching to auto occurs automatically. If switching to manual mode is done, however, the data from the last reset is displayed.

Auto reset mode

- When the average fuel consumption and average speed are being displayed, if you hold down the multi-information display switch, the average fuel consumption and average speed displayed at that time are reset.
- When the operation mode is in ACC or OFF for approximately 4 hours or longer, the average fuel consumption display and average speed display are automatically reset.

NOTE

- The average fuel consumption display and average speed display can be reset separately for the auto reset mode and for the manual reset mode.
- The memory of the auto reset mode or manual reset mode for the average fuel consumption display and average speed display is erased if the battery is disconnected.

Changing the fuel consumption display unit

E00523002023

The display unit for fuel consumption can be switched. The distance, speed, and amount units are also switched to match the selected fuel consumption unit.

5

1. Press and hold the multi-information display switch for approximately 2 seconds or more to switch from the setting mode screen to the menu screen.
Refer to “Changing the function settings” on page 5-12.
2. Lightly press the multi-information display switch to select **AVG UNIT** “AVG UNIT (fuel consumption display setting)”.
 3. Press and hold the multi-information display switch for approximately 2 seconds or more to display “AVG UNIT”.
 4. Lightly press the multi-information display switch to select the units.
 5. Press and hold the multi-information display switch for approximately 2 seconds or more to change the setting to the selected unit.

Multi-information display - Type 1

5

NOTE

- The display units for the driving range, the average fuel consumption, the average speed and the momentary fuel consumption are switched, but the units for the indicating needle (speedometer), the odometer and the trip-meter will remain unchanged.

The distance and speed units are also switched in the following combinations to match the selected fuel consumption unit.

Fuel consumption	Distance (driving range)	Speed (average speed)
L/100 km	km	km/h
mpg (US)	mile (s)	mph
mpg (UK)	mile (s)	mph
km/L	km	km/h

Changing the display language

E00523201914

The language of the multi-information display can be switched.

1. Press and hold the multi-information display switch for approximately 2 seconds or more to switch from the setting mode screen to the menu screen.

Refer to “Changing the function settings” on page 5-12.

2. Lightly press the multi-information display switch to select  LANGUAGE “LANGUAGE” (language setting).
3. Press and hold the multi-information display switch for approximately 2 seconds or more to display “LANGUAGE”.
4. Lightly press the multi-information display switch to select the desired language.
5. If you hold down the multi-information display switch for approximately 2 seconds or more, the setting is changed to the selected language.

NOTE

- If “--” is selected in the language setting, a warning message is not displayed when there is a warning display or interrupt display.

Operation sound setting

E00523401903

You can turn off the operation sounds of the multi-information display switch and rheostat illumination button.

1. Press and hold the multi-information display switch for approximately 2 seconds or more to switch from the setting mode screen to the menu screen.

Refer to “Changing the function settings” on page 5-12.

2. Lightly press the multi-information display switch to select  (operation sound setting).
3. Press and hold the multi-information display switch for approximately 2 seconds or more to switch from ON (operation sound on) to OFF (operation sound off), or from OFF to ON.
The setting is changed to the selected condition.

NOTE

- The operation sound setting only deactivates the operation sound of the multi-information display switch and rheostat illumination button. The warning display and other sounds cannot be deactivated.

Changing the time until “REST REMINDER” is displayed

E00523501975

The time until the display appears can be changed.

1. Press and hold the multi-information display switch for approximately 2 seconds or more to switch from the setting mode screen to the menu screen.

Multi-information display - Type 1

Refer to “Changing the function settings” on page 5-12.

2. Lightly press the multi-information display switch to select “ALARM” (rest time setting).
3. Press and hold the multi-information display switch for approximately 2 seconds or more to display “ALARM”.
4. Lightly press the multi-information display switch to select the time until the display.
5. Press and hold the multi-information display switch for approximately 2 seconds or more, the setting is changed to the selected time.

NOTE

- The drive time is reset when the operation mode is put in OFF.

Changing the turn-signal sound

E00529101595

It is possible to change the turn-signal sound.

1. Press and hold the multi-information display switch for approximately 2 seconds or more to switch from the setting mode screen to the menu screen.
Refer to “Changing the function settings” on page 5-12.

2. Lightly press the multi-information display switch to select  (changing the turn-signal sound).
3. Press and hold the multi-information display switch for approximately 2 seconds or more to switch from 1 (turn-signal sound 1) to 2 (turn-signal sound 2), or from 2 to 1.
The setting changes to the selected turn-signal sound.

Changing the momentary fuel consumption display

E00529201525

It is possible to change the bar graph setting of the momentary fuel consumption display.

1. Press and hold the multi-information display switch for approximately 2 seconds or more to switch from the setting mode screen to the menu screen.
Refer to “Changing the function settings” on page 5-12.
2. Lightly press the multi-information display switch to select  (changing the momentary fuel consumption display).
3. Press and hold the multi-information display switch for approximately 2 seconds or more to switch from ON (with the green bar graph) to OFF (without the green bar graph), or from OFF to ON.

The setting changes to the selected bar graph setting.

Returning to the factory settings

E00523602410

Many of the function settings can be returned to their factory settings.

1. Press and hold the multi-information display switch for approximately 2 seconds or more to switch from the setting mode screen to the menu screen.
Refer to “Changing the function settings” on page 5-12.
2. Lightly press the multi-information display switch to select “RESET” (returning to the factory settings).
3. When you press and hold the multi-information display switch for approximately 5 seconds or more, the buzzer sounds and all of the function settings are returned to the factory settings.

NOTE

- The factory settings are as follows.
 - Average fuel consumption and average speed reset mode: A (Auto reset)
 - Fuel consumption display unit: L/100 km
 - Display language: THAI
 - Operation sounds: ON (Operation sounds on)
 - “REST REMINDER” display: OFF

Multi-information display - Type 2

NOTE

- Turn-signal sound: Turn-signal sound 1
- Momentary fuel consumption with the green bar graph: ON

5- Service reminder → P.5-20

NOTE

- When the ignition switch is OFF, the information display and the service reminder are displayed.

5

Multi-information display - Type 2

E00519903611

Always stop the vehicle in a safe place before operating.

The following information is included on the multi-information display: odometer, tripmeter, average fuel consumption etc.

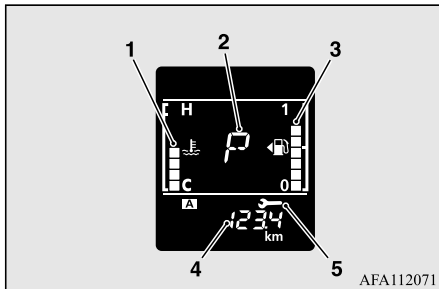

- 1- Engine coolant temperature display → P.5-19
- 2- Selector lever position indicator display → P.6-20
- 3- Fuel remaining display → P.5-19
- 4- Information display → P.5-17

5-16 Instruments and controls

Information display

E00528201573

Each time you lightly press the multi-information display switch (A), the display switches in the following order.

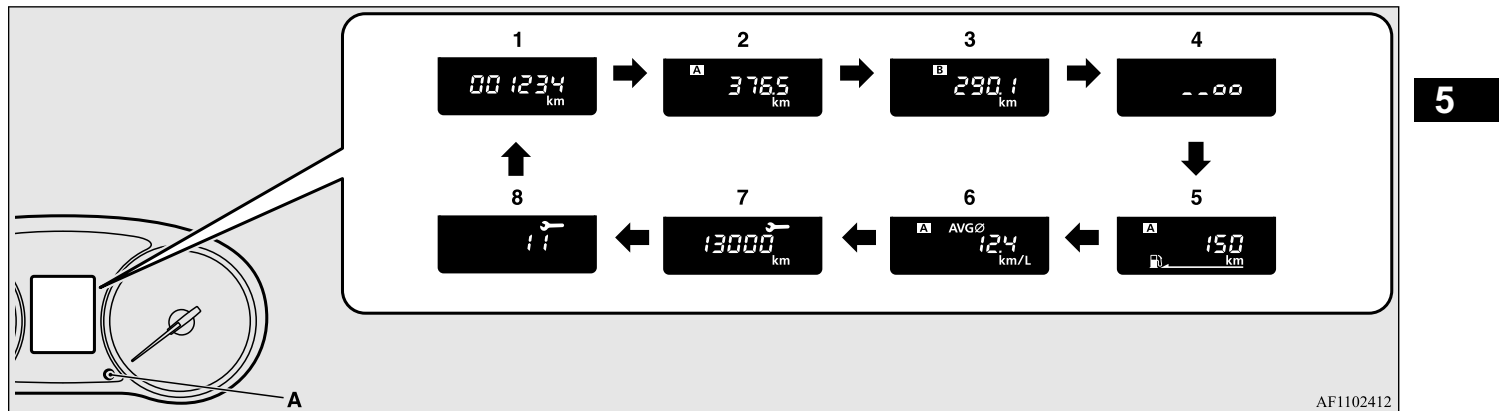

AF1102412

- | | |
|--|--|
| 1- Odometer → P.5-18 | 6- Average fuel consumption display → P.5-19 |
| 2- Tripmeter A → P.5-18 | 7- Service reminder (distance) → P.5-20 |
| 3- Tripmeter B → P.5-18 | 8- Service reminder (month) → P.5-20 |
| 4- Meter illumination control → P.5-18 | |
| 5- Driving range display → P.5-18 | |

NOTE

- When the ignition switch is OFF, the information display and the service reminder are displayed.
- While driving, the service reminder is not displayed even if you operate the multi-information display switch.

Multi-information display - Type 2

Odometer

E00527801181

The odometer indicates the distance travelled.

Tripmeter

E00527901212

5 The tripmeter indicates the distance travelled between two points.

Example usage of tripmeter **A** and tripmeter **B**

It is possible to measure two currently travelled distances, from home using tripmeter **A** and from a particular point on the way using tripmeter **B**.

To reset the tripmeter

To return the display to 0, hold down the multi-information display switch for approximately 2 seconds or more. Only the currently displayed value will be reset.

Example

If tripmeter **A** is displayed, only tripmeter **A** will be reset.

NOTE

- When disconnecting the battery terminal, the memory of tripmeter **A** and **B** are cleared, and the display returns to "0".

Meter illumination control

E00537901198

Each time you press and hold the multi-information display switch (2) for approximately 2 seconds or more, there is a sound and the brightness of the instruments changes.

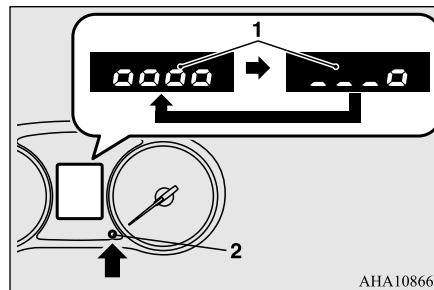

- 1- Brightness level
- 2- Multi-information display switch

NOTE

- You can adjust to 8 different levels respectively for when the position lamps are illuminated and when they are not. Each time you reduce two brightness levels, the segment display of the brightness level decreases one by one.
- The brightness level of the instruments is stored when the ignition switch is turned off.

Driving range display

E00538001138

This displays the approximate driving range (how many more kilometres or miles you can drive). When the driving range falls below approximately 50 km (30 miles), "---" is displayed.

NOTE

- The driving range is determined based on the fuel consumption data. This may vary depending on the driving conditions and habits. Treat the distance displayed as just a rough guideline.
- When you refuel, the driving range display is updated. However, if you only add a small amount of fuel, the correct value will not be displayed. Fill with a full tank whenever possible.

Multi-information display - Type 2

NOTE

- On rare occasions, the value displayed for the driving range may change if you are parked on an extremely steep incline. This is due to the movement of fuel in the tank and does not indicate any malfunction.
- The display setting can be changed to the preferred units (km or miles). Refer to “Changing the function settings” on page 5-21.

Average fuel consumption display

E00531201245

This displays the average fuel consumption from the last reset to the present time. The reset mode conditions for the average fuel consumption display can be switched between “Auto reset” and “Manual reset”. Refer to “Changing the reset mode for average fuel consumption” on page 5-21. For information on how to change the average fuel consumption display setting, refer to “Changing the function settings” on page 5-21.

NOTE

- The average fuel consumption display can be reset separately for the auto reset mode and for the manual reset mode.

NOTE

- “---” is displayed when the average fuel consumption cannot be measured.
- The initial (default) setting is “Auto reset mode”.
- The average fuel consumption will depend on the driving conditions (road conditions, how you drive, etc.). The displayed fuel consumption may vary from the actual fuel consumption. Treat the fuel consumption displayed as just a rough guideline.
- The memory of the manual reset mode or auto reset mode for the average fuel consumption display is erased if the battery is disconnected.
- The display setting can be changed to the preferred units {km/L, L/100 km, mpg}. Refer to “Changing the function settings” on page 5-21.

Engine coolant temperature display

E00533801216

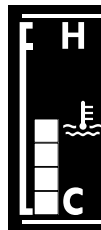

This indicates the engine coolant temperature.

If the coolant becomes hot,  will blink. Pay careful attention to the engine coolant temperature display while you are driving.

CAUTION

- If the engine is overheating,  will blink. In this case, the bar graph is on the red zone. Immediately park the vehicle in a safe place and take the required measures. Refer to “Engine overheating” on page 8-3.

5

Fuel remaining display

E0052201975

The fuel remaining display indicates the fuel level in the fuel tank when the ignition switch is ON.

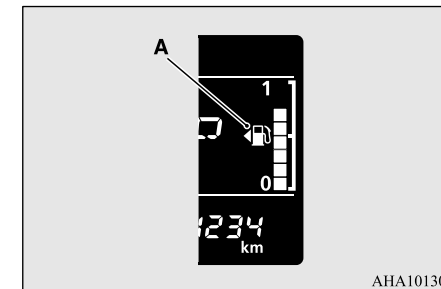

1- Full

Multi-information display - Type 2

0- Empty

5

NOTE

- It may take several seconds to stabilise the display after refilling the tank.
- If fuel is added with the ignition switch is ON, the fuel gauge may incorrectly indicate the fuel level.
- The arrow (A) indicates that the fuel tank filler door is located on the left side of the vehicle.

Fuel remaining warning display

E00522402411

If the remaining fuel level is approximately 8 litres or less (one segment displayed) when the ignition switch is turned to the “ON” position, the last segment of the fuel gauge flashes. If the warning display appears, refuel as soon as possible.

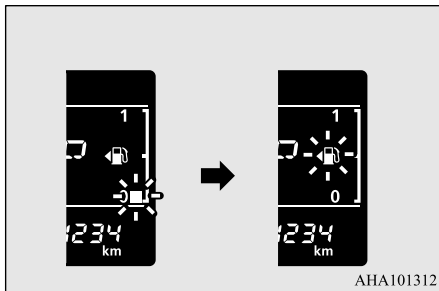

CAUTION

- Do not run out of fuel, or the catalytic converter may be adversely affected. If the warning display appears, refuel as soon as possible.
- If the fuel tank is almost empty, the last segment of the fuel gauge goes out and “” mark flashes. Refuel as soon as possible.

NOTE

- On inclines or curves, the display may be incorrect due to the movement of fuel in the tank.

Service reminder

E00522502379

Displays the approximate time until the next periodic inspection that MITSUBISHI MOTORS recommends. “---” is displayed when the inspection time has arrived. The spanner mark indicates the periodic inspection.

NOTE

- Depending on the vehicle specifications, the displayed time until the next periodic inspection may differ from that of MITSUBISHI MOTORS recommends. In addition, the display settings for the next periodic inspection time can be modified. To modify the display settings, have it adjusted at an authorised MITSUBISHI MOTORS dealer. For more details, contact an authorised MITSUBISHI MOTORS dealer.

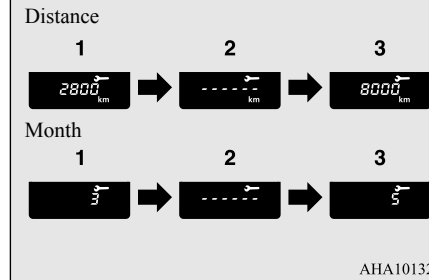

1. Displays the time until the next periodic inspection.

NOTE

- The distance is shown in units of 100 km (100 miles). The time is shown in units of months.

- This informs you that a periodic inspection is due. Please consult an authorised MITSUBISHI MOTORS dealer.
- After your vehicle is inspected at an authorised MITSUBISHI MOTORS dealer, it displays the time until the next periodic inspection.

To reset

The “---” display can be reset while the ignition switch is in OFF.

- When you lightly press the multi-information display switch a few times, the information display switches to the service reminder display. Refer to “Information display” on page 5-17.
- Press and hold the multi-information display switch for approximately 2 seconds or more to make the spanner mark start flashing. (If there is no operation for approximately 10 seconds with flashing, the display will revert to its original indication.)
- Lightly press the multi-information display switch while the icon is flashing to change the display from “---” to “cLEAR”. After this, the time until the next periodic inspection will be displayed.

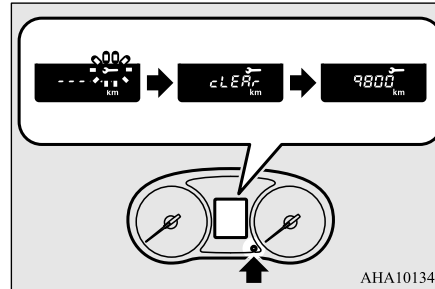

CAUTION

- The customer is responsible for making sure that periodic inspection and maintenance are performed. Inspections and maintenance must be performed to prevent accidents and malfunctions.

NOTE

- “---” display cannot be reset when the ignition switch is in ON.
- When “---” is displayed, after a certain distance and a certain period of time, the display is reset and the time until the next periodic inspection is displayed.
- If you accidentally reset the display, consult an authorised MITSUBISHI MOTORS dealer.

Changing the function settings

E00522702469

The “Average fuel consumption reset mode” and “Fuel consumption unit” setting can be modified as desired, when the ignition switch is ON.

CAUTION

- The driver should not operate the display while the vehicle is in motion.
- When operating the system, stop the vehicle in a safe area.

Changing the reset mode for average fuel consumption

E00522902399

The mode conditions for the average fuel consumption display can be switched between “Auto reset” and “Manual reset”.

- When you lightly press the multi-information display switch a few times, the information display switches to the driving range display. Refer to “Information display” on page 5-17.
- Each time you press the multi-information display switch for 2 seconds or more on driving range display, you can switch reset mode for average fuel consumption.

Multi-information display - Type 2

(A: Auto reset mode, B: Manual reset mode)

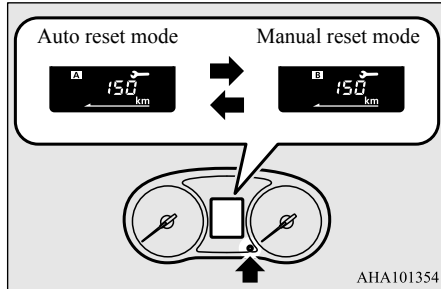

5

Manual reset mode

- When the average fuel consumption is being displayed, if you hold down the multi-information display switch, the average fuel consumption displayed at that time is reset.
- When the ignition switch is turned from the “ACC” or “LOCK” position to the “ON” position, the mode setting is automatically switched from manual to auto.

Switching to auto occurs automatically. If switching to manual mode is done, however, the data from the last reset is displayed.

Auto reset mode

- When the average fuel consumption is being displayed, if you hold down the multi-information display switch, the average fuel consumption displayed at that time are reset.
- When the ignition switch is in the “ACC” or “LOCK” position for approximately 4 hours or longer, the average fuel consumption display is automatically reset.

NOTE

- The average fuel consumption display can be reset separately for the auto reset mode and for the manual reset mode.
- The memory of the manual reset mode or auto reset mode for the average fuel consumption display is erased if the battery is disconnected.
- The initial (default) setting is “Auto reset mode”.

Changing the fuel consumption display unit

E00523001954

The display unit for fuel consumption can be switched. The distance and amount units are also switched to match the selected fuel consumption unit.

1. When you lightly press the multi-information display switch a few times, the information display switches to the average fuel consumption display. Refer to “Information display” on page 5-17.
2. Press and hold the multi-information display switch for approximately 5 seconds or more until buzzer sound is heard twice.
3. Press and hold the multi-information display switch to switch in sequence from “km/L” → “L/100 km” → “mpg” → “km/L”.

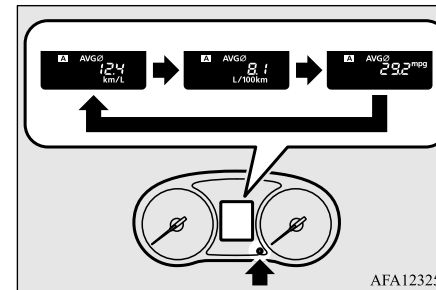

NOTE

- The display units for the driving range, the average fuel consumption are switched, but the units for the indicating needle (speedometer), the odometer, the tripmeter and the service reminder will remain unchanged.

Indicator lamp, warning lamp, and information screen display list (multi-information display - Type 1)

NOTE

- The memory of the unit setting is erased if the battery is disconnected, and it returns automatically to factory setting.

The distance units is also switched in the following combinations to match the selected fuel consumption unit.

Fuel consumption	Distance (driving range)
km/L	km
L/100 km	km
mpg	mile (s)

Indicator lamp, warning lamp, and information screen display list (multi-information display - Type 1)

5

E00523701397

Indicator and warning lamp list

E00523803044

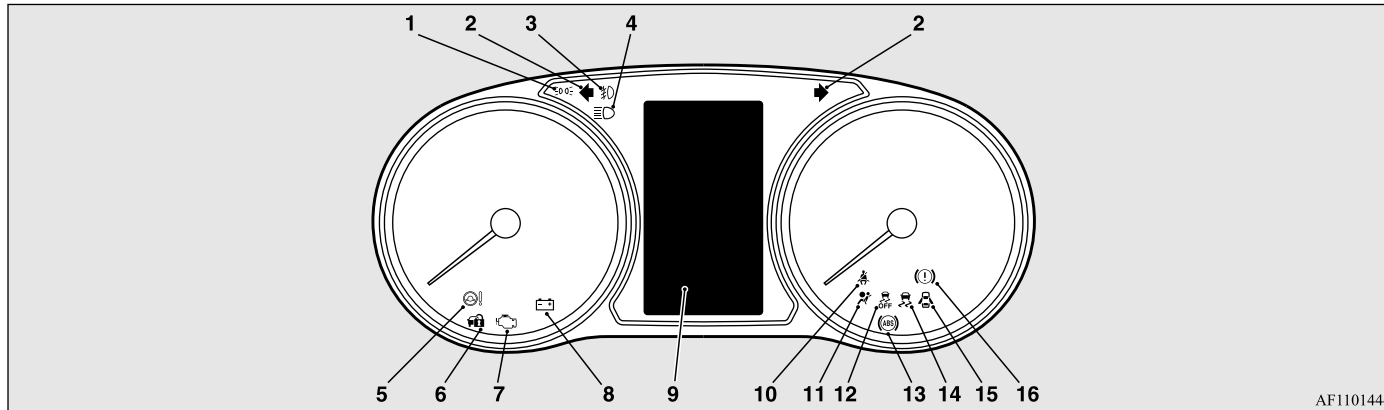

AF1101444

1- Position lamp indicator lamp → P.5-34

2- Turn-signal indicator lamps/Hazard warning indicator lamps → P.5-33

3- Front fog lamp indicator lamp → P.5-34

Indicator lamp, warning lamp, and information screen display list (multi-information display - Type 1)

5

- 4- High-beam indicator lamp → P.5-34
- 5- Electric power steering system (EPS) warning lamp → P.6-31
- 6- Security indicator lamp → P.3-19
- 7- Check engine warning lamp → P.5-35
- 8- Charge warning lamp → P.5-35
- 9- Information screen display → P.5-24
- 10- Seat belt warning lamp → P.4-12
- 11- Supplemental restraint system (SRS) warning lamp → P.4-27
- 12- Active Stability Control (ASC) OFF indicator lamp → P.6-33
- 13- Anti-lock brake system (ABS) warning lamp → P.6-29
- 14- Active Stability Control (ASC) indicator lamp → P.6-33
- 15- Door-ajar warning lamp → P.5-36
- 16- Brake warning lamp → P.5-34

Information screen display

E00523901575

When there is information to be announced, such as lamp reminder, the buzzer sounds and the screen switches to the displays shown below. Refer to the appropriate page and take the necessary measures.

When the cause of the warning display is eliminated, the warning display goes out automatically.

Refer to “Warning display list” on page 5-25.

Refer to “Other interrupt display list” on page 5-31.

Indicator lamp, warning lamp, and information screen display list (multi-information display - Type 1)



 **NOTE**

- A warning may be displayed on the information screen and the buzzer may sound in the following rare cases.
This is caused by the system picking up interference such as noise or strong electromagnetic waves, and is not a functional problem.
 - An extremely strong electromagnetic wave is received from a source such as an illegal radio set, a spark from a wire, or a radar station.
 - Abnormal voltage or a static electricity discharge is generated by the operation of installed electrical equipment (including after-market parts).
- If the warning display appears many times, consult an authorised MITSUBISHI MOTORS dealer.

5







Warning display list

E00524002844







Screen	Cause	Solution (Reference)
 <p>IMMOBILIZER SYSTEM SERVICE REQUIRED</p>	<ul style="list-style-type: none"> • There is a fault in the electronic immobilizer (Anti-theft starting system). 	<ul style="list-style-type: none"> • Put the operation mode in OFF, and then start the engine again. If the warning is not cancelled, please contact an authorised MITSUBISHI MOTORS dealer.
 <p>ELECTRICAL SYSTEM SERVICE REQUIRED</p>	<ul style="list-style-type: none"> • There is a fault in the electrical system. 	<ul style="list-style-type: none"> • Immediately stop the vehicle in a safe place and consult an authorised MITSUBISHI MOTORS dealer.

Indicator lamp, warning lamp, and information screen display list (multi-information display - Type 1)

5

Screen	Cause	Solution (Reference)
 KEY BATTERY LOW  KEY NOT DETECTED  KEY STILL IN VEHICLE  CHECK DOORS  KEYLESS OPERATION SYSTEM SERVICE REQUIRED	<ul style="list-style-type: none"> There is a fault in the keyless operation system. 	<p>Refer to “Keyless operation system” on page 3-7.</p>
<p>Engine switch is pressed 1 time</p>  KEY NOT DETECTED <p>Engine switch is pressed 2 times or more</p>  KEY NOT DETECTED TOUCH SWITCH WITH KEY	<ul style="list-style-type: none"> Although the engine switch was pressed, the keyless operation key could not be detected. 	<ul style="list-style-type: none"> Touch the keyless operation key to the engine switch. Refer to “If the keyless operation key is not operating properly” on page 6-18.





Indicator lamp, warning lamp, and information screen display list (multi-information display - Type 1)

Screen	Cause	Solution (Reference)
	<ul style="list-style-type: none"> You put the operation mode in ON without fastening your seat belt. 	<ul style="list-style-type: none"> Fasten your seat belt properly. Refer to “Seat belt reminder” on page 4-12.
	<ul style="list-style-type: none"> There is a fault in the SRS airbag or the pre-tensioner system. 	<ul style="list-style-type: none"> Contact an authorised MITSUBISHI MOTORS dealer to have the system checked, immediately. Refer to “SRS warning lamp/display” on page 4-27.
	<ul style="list-style-type: none"> The fuel is running low. 	<ul style="list-style-type: none"> Refuel as soon as possible. Refer to “Fuel remaining warning display” on page 5-7.
	<ul style="list-style-type: none"> There is a fault in the fuel system. 	<ul style="list-style-type: none"> Have your vehicle inspected at an authorised MITSUBISHI MOTORS dealer.
	<ul style="list-style-type: none"> You are driving with the parking brake still applied. 	<ul style="list-style-type: none"> Release the parking brake. Refer to “Brake warning display” on page 5-36.
	<ul style="list-style-type: none"> The brake fluid level in the reservoir has fallen to a low level. There is a fault in the brake system. 	<ul style="list-style-type: none"> Immediately stop the vehicle in a safe place and consult an authorised MITSUBISHI MOTORS dealer. Refer to “Brake warning display” on page 5-36.







5

Indicator lamp, warning lamp, and information screen display list (multi-information display - Type 1)

5

Screen	Cause	Solution (Reference)
 <p>CHARGING SYSTEM SERVICE REQUIRED</p>	<ul style="list-style-type: none"> ● There is a fault in the charging system. 	<ul style="list-style-type: none"> ● Immediately stop the vehicle in a safe place and consult the nearest authorised MITSUBISHI MOTORS dealer. Refer to “Charge warning display” on page 5-37.
 <p>LOW OIL PRESSURE</p>	<ul style="list-style-type: none"> ● There is a fault in the engine oil circulation system. 	<ul style="list-style-type: none"> ● Immediately stop the vehicle in a safe place and consult the nearest authorised MITSUBISHI MOTORS dealer. Refer to “Oil pressure warning display” on page 5-37.
 <p>TURN OFF LIGHTS</p>	<ul style="list-style-type: none"> ● You have forgotten to turn off the lamps. 	<p>Refer to “Lamps (headlamps, fog lamp, etc.) auto-cutout function” on page 5-38.</p>
 <p>OFF</p>	<ul style="list-style-type: none"> ● The driver’s door is open when the operation mode is in any mode other than OFF. 	<ul style="list-style-type: none"> ● Put the operation mode in OFF. Refer to “Operation mode ON reminder system” on page 6-13.
	<ul style="list-style-type: none"> ● An attempt was made to lock all the doors and the tailgate when the operation mode is in any mode other than OFF. 	<ul style="list-style-type: none"> ● Put the operation mode in OFF. Refer to “Operation mode OFF reminder system” on page 6-13.
 <p>STEERING LOCK SERVICE REQUIRED</p>	<ul style="list-style-type: none"> ● There is a fault in the steering wheel lock. 	<ul style="list-style-type: none"> ● Immediately stop the vehicle in a safe place and consult an authorised MITSUBISHI MOTORS dealer.



Indicator lamp, warning lamp, and information screen display list (multi-information display - Type 1)

Screen	Cause	Solution (Reference)
 <p>PUSH ENGINE SWITCH WHILE TURNING STEERING WHEEL</p>	<ul style="list-style-type: none"> The steering wheel is locked. 	<ul style="list-style-type: none"> Press the engine switch while turning steering wheel. <p>Refer to “Steering wheel lock” on page 6-13.</p>
 <p>SHIFT TO P POSITION</p>	<ul style="list-style-type: none"> The engine is stopped while the selector lever is in a position other than the “P” (PARK) position. 	<ul style="list-style-type: none"> Place the selector lever in the “P” (PARK) position to put the operation mode in OFF.
 <p>STEERING WHEEL UNLOCKED</p>	<ul style="list-style-type: none"> The driver’s door is opened with the steering wheel unlocked. 	<p>Refer to “Steering wheel lock” on page 6-13.</p>
 <p>POWER STEERING SERVICE REQUIRED</p>	<ul style="list-style-type: none"> There is a fault in the EPS. 	<ul style="list-style-type: none"> Have the vehicle inspected by an authorised MITSUBISHI MOTORS dealer as soon as possible. <p>Refer to “Electric power steering system (EPS)” on page 6-31.</p>
 <p>TRANSMISSION OVERHEATING SLOW DOWN</p>	<ul style="list-style-type: none"> The A/T fluid temperature is too high. 	<p>Refer to “4-speed automatic transmission: When a malfunction occurs in the A/T” on page 6-23.</p>
 <p>TRANSMISSION SERVICE REQUIRED</p>	<ul style="list-style-type: none"> There is a fault in the A/T. 	<ul style="list-style-type: none"> Have your vehicle inspected at an authorised MITSUBISHI MOTORS dealer. <p>Refer to “4-speed automatic transmission: When a malfunction occurs in the A/T” on page 6-23.</p>

5

Indicator lamp, warning lamp, and information screen display list (multi-information display - Type 1)

5

Screen	Cause	Solution (Reference)
	<ul style="list-style-type: none"> ● There is a fault in the hill start assist. 	<ul style="list-style-type: none"> ● Have your vehicle inspected at an authorised MITSUBISHI MOTORS dealer. Refer to “Warning lamp/display” on page 6-27.
	<ul style="list-style-type: none"> ● There is a fault in the active stability control (ASC). 	<ul style="list-style-type: none"> ● Have your vehicle inspected at an authorised MITSUBISHI MOTORS dealer. Refer to “ASC warning lamp/display” on page 6-34.
	<ul style="list-style-type: none"> ● There is a fault in the ABS. 	<ul style="list-style-type: none"> ● Avoid sudden braking and high-speed driving, stop the vehicle in a safe place, and take corrective measures. Refer to “ABS warning lamp/display” on page 6-30.
	<ul style="list-style-type: none"> ● The engine is overheated. 	<ul style="list-style-type: none"> ● Stop the vehicle in a safe place and take corrective measures. Refer to “Engine overheating” on page 8-3.

Indicator lamp, warning lamp, and information screen display list (multi-information display - Type 1)

Other interrupt display list

E00524202820

Screen	System operation status	Reference
	<ul style="list-style-type: none"> When starting the engine, the selector lever is in a position other than the “P” (PARK) or the “N” (NEUTRAL) position, or you pressed the engine switch without depressing the brake pedal. 	<ul style="list-style-type: none"> Place the selector lever in the “P” (PARK) position, depress the brake pedal with the right foot. Then, press the engine switch. Refer to “Starting the engine” on page 6-16.
	<ul style="list-style-type: none"> When communication was successful when the keyless operation key was touched to the engine switch. 	Refer to “If the keyless operation key is not operating properly” on page 6-18.

5

This informs you that a periodic inspection is due.

Screen	Solution
	We recommend you to have it checked. Refer to “Service reminder” for further details on page 5-8.

Indicator lamp, warning lamp, and information screen display list (multi-information display - Type 1)

The setting for rest interval can be changed.

5

Screen	Solution
 <p>The image shows a black rectangular screen with a white coffee cup icon at the top and the text "REST REMINDER" in white capital letters below it.</p>	<p>Stop the vehicle in a safe place, turn off the engine, and take a rest. Use this display as rough guide for taking rests during a long drive. The interval from the start of your trip until this message is displayed can be set. Refer to "Changing the time until "REST REMINDER" is displayed" on page 5-14. The display and buzzer alert the driver when the set time is reached. If you continue to drive without having a rest, the buzzer sounds approximately every 5 minutes to encourage you to take a rest.</p> <ul style="list-style-type: none"> ● In the following cases, the time driven is reset and the display returns to the previous display screen. After this, when the set time is reached again, the buzzer and display encourage you to take a rest. <ul style="list-style-type: none"> • The buzzer sounds 3 times. • Put the operation mode in OFF. • The multi-information display switch is held for approximately 2 seconds or more.

Indicator and warning lamps (multi-information display - Type 2)

E00501504572

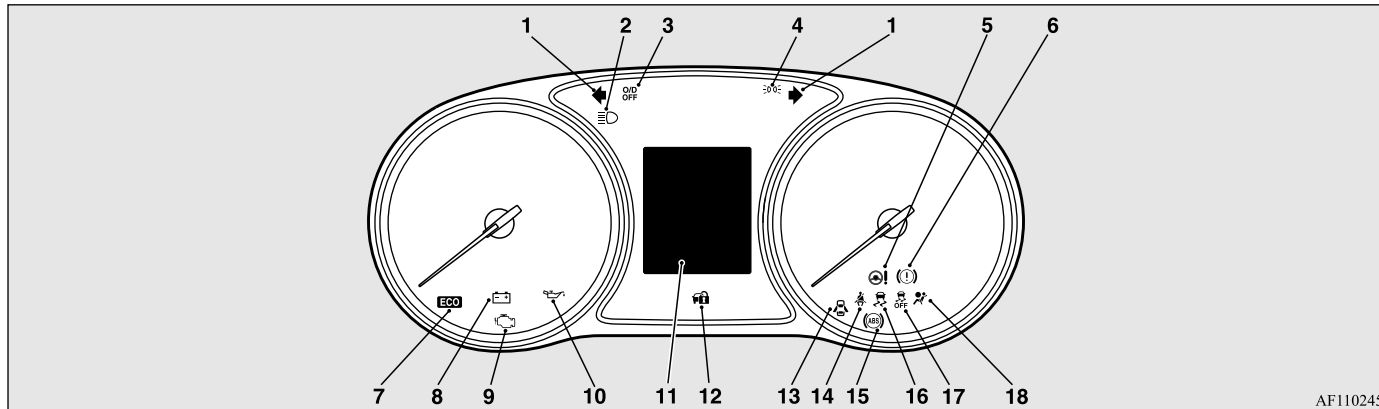

5

AF1102454

- 1- Turn-signal indicator lamps/Hazard warning indicator lamps → P.5-33
- 2- High-beam indicator lamp → P.5-34
- 3- Overdrive OFF indicator lamp → P.6-22
- 4- Position lamp indicator lamp → P.5-34
- 5- Electric power steering system (EPS) warning lamp → P.6-31
- 6- Brake warning lamp → P.5-34
- 7- ECO indicator lamp → P.5-34
- 8- Charge warning lamp → P.5-35
- 9- Check engine warning lamp → P.5-35
- 10- Oil pressure warning lamp → P.5-36
- 11- Multi-information display → P.5-16
- 12- Security indicator lamp → P.3-19
For details, refer to “Steering wheel lock” on page 6-13.
- 13- Door-ajar warning lamp → P.5-36
- 14- Seat belt warning lamp → P.4-27
- 15- Anti-lock brake system (ABS) warning lamp → P.6-29
- 16- Active Stability Control (ASC) indicator lamp → P.6-33
- 17- Active Stability Control (ASC) OFF indicator lamp → P.6-33
- 18- Supplemental restraint system (SRS) warning lamp → P.4-27

Indicator lamps

E00501601266

Turn-signal indicator lamps/Hazard warning indicator lamps

E00501701762

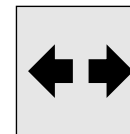

These indicator lamps blink on and off when a turn-signal lamp is operating.

Warning lamps

NOTE

- If the blinking is too fast, the cause may be a blown lamp bulb or a faulty turn-signal connection.

5

- When the hazard warning lamp switch is pressed, all turn-signal lamps will flash on and off continuously.
- When the hazard warning lamps automatically activate due to sudden braking while driving. Refer to “Emergency stop signal system” on page 6-28.

High-beam indicator lamp

E00501801372

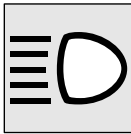

This indicator lamp illuminates when the high-beam is used.

Front fog lamp indicator lamp*

E00501901748

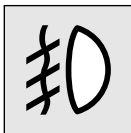

This lamp illuminates while the front fog lamps are on.

Position lamp indicator lamp

E00508901385

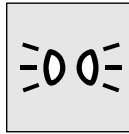

This indicator lamp illuminates while the position lamps are on.

ECO indicator lamp (vehicle equipped with the multi-information display - Type 2)

E00529801198



This indicator lamp illuminates when fuel-efficient driving is achieved.

Warning lamps

E00502401492

Brake warning lamp

E00502504061



This lamp illuminates when the ignition switch is turned to the “ON” position or the operation mode is put in ON, and goes off after a few seconds.

Always make sure that the lamp goes off before driving.

With the ignition switch or the operation mode in ON, the brake warning lamp illuminates under the following conditions:

- When the parking brake has been applied.
- When the brake fluid level in the reservoir falls to a low level.
- When the brake force distribution function is not operating correctly.

With the ignition switch or the operation mode in ON, a buzzer sounds under the condition that the vehicle speed exceeds a certain speed with the parking brake applied.

CAUTION

- In the situations listed below, brake performance may be compromised or the vehicle may become unstable if brakes are applied suddenly; consequently, avoid driving at high speeds or applying the brakes suddenly. Furthermore, immediately the vehicle should be brought to a stop in a safe location and your nearest authorised MITSUBISHI MOTORS dealer should be contacted.
- The brake warning lamp does not illuminate when the parking brake is applied or does not turn off when the parking brake is released.

⚠ CAUTION

- The brake warning lamp and the ABS warning lamp illuminate at the same time. For details, refer to “ABS warning lamp/display” on page 6-30.
- The brake warning lamp remains illuminated while driving.
- The vehicle should be brought to a halt in the following manner when brake performance has deteriorated.
 - Depress the brake pedal harder than usual. Even if the brake pedal moves down to the very end of its possible stroke, keep it pressed down hard.
 - Should the brakes fail, use engine braking to reduce your speed and carefully pull the parking brake lever.

Depress the brake pedal to operate the stop lamp to alert the vehicles behind you.

Check engine warning lamp

E00502603355

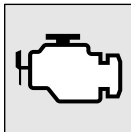

This lamp is a part of an onboard diagnostic system which monitors the emissions, engine control system or A/T control system.

If a problem is detected in one of these systems, this lamp illuminates or flashes. Although your vehicle will usually be drivable and not need towing, we recommend you

to have the system checked as soon as possible.

This lamp will also illuminate when the ignition switch is turned “ON” or the operation mode is put in ON, and goes off after the engine has started. If it does not go off after the engine has started, we recommend you to have the vehicle checked.

⚠ CAUTION

- Prolonged driving with this lamp on may cause further damage to the emission control system. It could also affect fuel economy and drivability.
- If the lamp does not illuminate when the ignition switch is turned to the “ON” position or the operation mode is put in ON, we recommend you to have the system checked.
- If the lamp illuminates while the engine is running, avoid driving at high speeds and have the system inspected by an authorised MITSUBISHI MOTORS dealer as soon as possible. Accelerator pedal and brake pedal response may be negatively influenced under these conditions.

📖 NOTE

- The engine electronic control module accommodating the onboard diagnostic system has various fault data (especially about the exhaust emission) stored.

This data will be erased if a battery cable is disconnected which will make a rapid diagnosis difficult. Do not disconnect a battery cable when the check engine warning lamp is ON.

Charge warning lamp

E00502702450

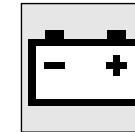

This lamp illuminates when the ignition switch is turned to the “ON” position or the operation mode is put in ON, and goes off after the engine has started.

On vehicle equipped with the multi-information display - type 1, a warning is also displayed on the multi-information display.

⚠ CAUTION

- If it illuminates while the engine is running, there is a problem in the charging system. Immediately park your vehicle in a safe place and we recommend you to have it checked.

5

Information screen display (vehicle equipped with the multi-information display - Type 1)

**Oil pressure warning lamp
(vehicle equipped with the
multi-information display -
Type 2)**

E00502801887

5



This lamp illuminates when the ignition switch is turned to the "ON" position, and goes off after the engine has started. If it illuminates while the engine is running, the oil pressure is too low.

Turn the engine off and have it inspected.

CAUTION

- If the vehicle is driven while the engine oil is low, or the oil level is normal but the warning lamp is illuminated, the engine may burn out and be damaged.
- If the warning lamp is illuminated while the engine is running, immediately park your vehicle in a safe place and check the engine oil level.
Refer to "Maintenance: Engine oil" on page 10-4.
- If the warning lamp is illuminated while the engine oil level is normal, have it inspected.

NOTE

- This warning lamp does not indicate the amount of oil level in the engine. This must be determined by checking the oil level on the dipstick, while the engine is switched off.

Door-ajar warning lamp

E00503302088

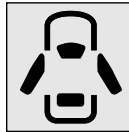

This lamp illuminates when a door or the tailgate is either open or not completely closed. If the vehicle speed reaches approximately 8 km/h with a door or the tailgate open or incompletely closed, a buzzer sounds 4 times as a warning.

CAUTION

- Before moving your vehicle, check that the warning lamp is OFF.

**Information screen display
(vehicle equipped with the
multi-information display -
Type 1)**

E00524601276

Brake warning display

E00524701613



This warning is displayed if you drive with the parking brake still applied. The warning lamp in the instrument cluster also illuminates when the parking brake is applied. If this warning is displayed, lower the parking brake lever fully.

CAUTION

- If a vehicle is driven without releasing the parking brake, the brake will be overheated, resulting in ineffective braking and possible brake failure.



When the operation mode is put in ON, if the brake fluid is low, this warning is displayed. The warning lamp in the instrument cluster also illuminates.

CAUTION

- If this warning stays illuminated and does not go out while driving, there is a danger of ineffective braking. If this happens, immediately park your vehicle in a safe place and we recommend you to have it checked.
- If the brake warning display is displayed and the brake warning lamp and the ABS warning lamp are illuminated at the same time, the braking force distribution function will not operate, so the vehicle may be destabilised during sudden braking. Avoid sudden braking and high-speed driving, stop the vehicle in a safe place, and we recommend you to have it checked.
- The vehicle should be brought to a halt in the following manner when brake performance has deteriorated.
 - Depress the brake pedal harder than usual. Even if the brake pedal moves down to the very end of its possible stroke, keep it pressed down hard.

CAUTION

- Should the brakes fail, use engine braking to reduce your speed and carefully pull the parking brake lever.

Depress the brake pedal to operate the stop lamp to alert the vehicles behind you.

Charge warning display



If there is a fault with the charging system, the warning display is displayed on the information screen in the multi-information display. The warning lamp in the instrument cluster also illuminates.

CAUTION

- If the warning is displayed while the engine is running, immediately park your vehicle in a safe place and we recommend you to have it checked.

Oil pressure warning display



If the engine oil pressure drops while the engine is running, the warning display is displayed on the information screen in the multi-information display.

CAUTION

- If the vehicle is driven while the engine oil is low, or the oil level is normal but the warning is displayed, the engine may burn out and be damaged.
- If the warning is displayed while the engine is running, immediately park your vehicle in a safe place and check the engine oil level. Refer to “Maintenance: Engine oil” on page 10-4.
- If the warning is displayed while the engine oil level is normal, have it inspected.

NOTE

- This warning display does not indicate the amount of oil level in the engine. This must be determined by checking the oil level on the dipstick, while the engine is switched off.

Combination headlamps and dipper switch

E00506005250

Headlamps

5

NOTE

- Do not leave the lamps on for a long time while the engine is stationary (not running). A run-down battery could result.
- When it rains, or when the vehicle has been washed, the inside of the lens sometimes becomes foggy, but this does not indicate a functional problem.
When the lamp is switched on, the heat will remove the fog. However, if water gathers inside the lamp, we recommend you to have checked.

Rotate the switch to turn on the lamps.

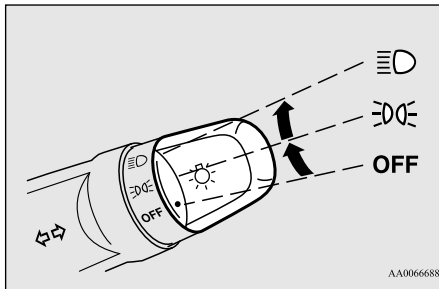

AA0066688

OFF	All lamps off
	Position, tail, licence plate and instrument panel lamps on
	Headlamps and other lamps go on

Lamps (headlamps, fog lamp, etc.) auto-cutout function

E00532701931

- If the following operation is performed while the lamp switch is in the “” position, the lamps are automatically turned off when the driver’s door is opened.
[Except for vehicles equipped with the keyless operation system]
The ignition switch is turned to the “LOCK” or “ACC” position, or the key is removed from the ignition switch.
[For vehicles equipped with the keyless operation system]
The operation mode is put in OFF or ACC.
- If the following operation is performed while the lamp switch is in the “” position, the lamps are automatically turned off if the driver’s door then remains closed for approximately 3 minutes.
[Except for vehicles equipped with the keyless operation system]

The ignition switch is turned to the “LOCK” or “ACC” position, or the key is removed from the ignition switch.
[For vehicles equipped with the keyless operation system]
The operation mode is put in OFF or ACC.

NOTE

- The lamp auto-cutout will not function when the lamp switch is in the “” position.
- The lamp auto-cutout function can also be disabled.
For further information, please contact an authorised MITSUBISHI MOTORS dealer.

When you want to keep the lamps on:

1. In the following cases, turn the lamp switch to the “OFF” position.
[Except for vehicles equipped with the keyless operation system]
The ignition switch is in the “LOCK” or “ACC” position.
[For vehicles equipped with the keyless operation system]
The operation mode is in OFF or ACC.
2. Turn on the lamps with the switch in the “” or “” position again, then the lamps will remain on.

Lamp monitor buzzer

E00506101862

If the following operation is performed, a buzzer will sound to remind the driver to turn off the lamps.

[Except for vehicles equipped with the keyless operation system]

If the driver's door is opened when the key is in the "LOCK" or "ACC" position or removed from the ignition switch while the lamps are on.

[For vehicles equipped with the keyless operation system]

If the driver's door is opened when the operation mode is in ACC or OFF while the lamps are on.

In both cases, the buzzer will automatically stop if the auto-cutoff function is activated, the lamp switch is turned off, or the door is closed.

Dipper (high/low beam change)

E00506201948

When the lamp switch is in the "D" position, the beam changes from high to low (or low to high) each time the lever is pulled fully (1). While the high-beam is on, the high-beam indicator lamp in the instrument cluster will also illuminate.

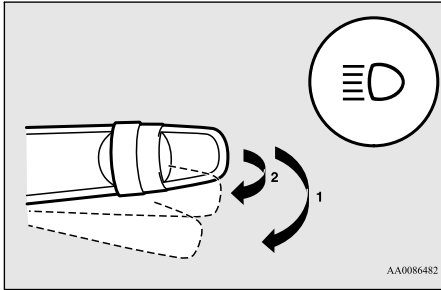

Headlamp flasher

E00506301486

The high-beams flash when the lever is pulled slightly (2), and will go off when it is released.

When the high-beam is on, the high-beam indicator lamp in the instrument cluster will illuminate.

NOTE

- The high-beams can also flash when the lamp switch is OFF.
- If you turn the lamps off with the headlamps set to high-beam, the headlamps are automatically returned to their low-beam setting when the lamp switch is next turned to the "D" position.

Welcome light

E00528902506

This function turns on the position and tail lamps for approximately 30 seconds after the UNLOCK switch on the key is pressed when the combination headlamps and dipper switch is in the "OFF" position.

5

NOTE

- While the welcome light function is operating, perform one of the following operations to cancel the function.
 - Press the LOCK switch on the key.
 - Turn the combination headlamps and dipper switch to the "D" or "D" position.
 - Turn the ignition switch to the "ON" position or put the operation mode in ON.
 - It is possible to modify functions as follows:
 - The headlamps can be set to come on in the low beam setting.
 - The welcome light function can be deactivated.
- For further information, please contact an authorised MITSUBISHI MOTORS dealer.

Coming home light

E00529002197

This function turns on the headlamps in the low beam setting for approximately 30 seconds after the ignition switch is turned to the

Turn-signal lever

“OFF” position or the operation mode is put in OFF.

1. Turn the combination headlamps and dipper switch to the “OFF” position.
2. Turn the ignition switch to the “LOCK” position or put the operation mode in OFF. Also, if a key was used to start the engine, remove the key from the ignition switch.
3. Within 60 seconds of turning the ignition switch to the “LOCK” position or putting the operation mode in OFF, pull the turn-signal lever towards you.

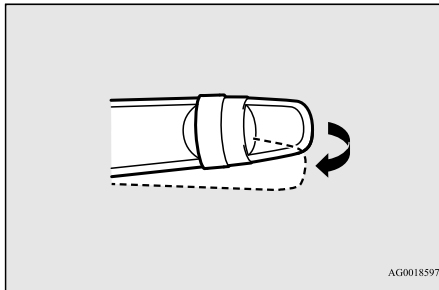

4. The headlamps will come on in the low beam setting for approximately 30 seconds. After the headlamps go off, the headlamps can be turned on again in the low beam setting for approximately 30 seconds by pulling the turn-signal lever towards you within 60 seconds of turning the ignition switch to the “OFF” position or putting the operation mode in OFF.

To turn on the headlamps again after 60 seconds of turning the ignition switch to the “LOCK” position or putting the operation mode in OFF, repeat the process from step 1.

NOTE

- While the coming home light function is operating, perform one of the following operations to cancel the function.
 - Pull the turn-signal lever towards you.
 - Turn the combination headlamps and dipper switch to the “

For further information, please contact an authorised MITSUBISHI MOTORS dealer.

Turn-signal lever

E00506503264

The turn-signal lamps flash when the lever is operated (with the ignition switch or the operation mode is in ON). At the same time, the turn-signal indicator flashes.

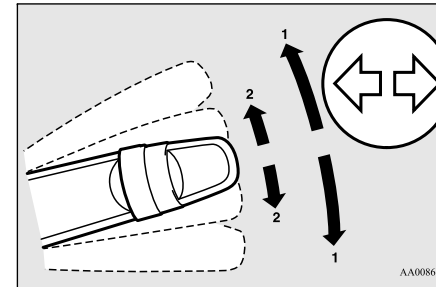

1- Turn-signals

When making a normal turn, use position (1). The lever will return automatically when cornering is completed.

2- Lane-change signals

When moving the lever to (2) slightly to change a lane, the turn-signal lamps and indicator lamp in the instrument cluster will only flash while the lever is operated.

Also, when you move the lever to (2) slightly then release it, the turn-signal lamps and indicator lamp in the instrument cluster will flash 3 times.

NOTE

- If the lamp flashes unusually quickly, the bulb in a turn-signal lamp may have burned out. Have the vehicle inspected by an authorised MITSUBISHI MOTORS dealer.
 - It is possible to activate the following functions:
 - Flashing of the turn-signal lamps when the lever is operated with the ignition switch or the operation mode is in ACC.
 - The turn-signal lamps 3-flash function for lane changes can be deactivated.
 - The time required to operate the lever for the 3-flash function can be adjusted.
- For further information, please contact an authorised MITSUBISHI MOTORS dealer.
- It is possible to change the tone of a sounding buzzer as the turn-signal lamps flash. [Vehicle equipped with the multi-information display - type 1]
Refer to “Changing the turn-signal sound” on page 5-15.
[Vehicle equipped with the multi-information display - type 2]
For further information, please contact an authorised MITSUBISHI MOTORS dealer.

Hazard warning flasher switch

E00506602398

Use the hazard warning flasher switch when the vehicle has to be parked on the road for any emergency.

The hazard warning flashers can always be operated, regardless of the ignition switch position or the operation mode.

Press the switch to turn on the hazard warning flashers, all turn-signal lamps flash continuously.

To turn them off, press the switch again.

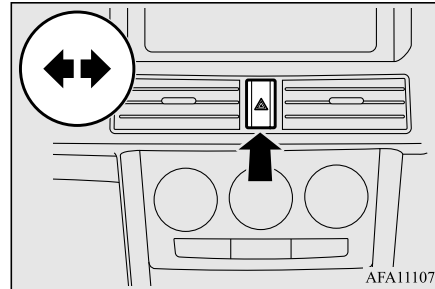

AFA111074

NOTE

- While the hazard warning lamps are blinking due to having manually pressed the switch, the emergency stop signal system does not operate. Refer to “Emergency stop signal system” on page 6-28.

Front fog lamp switch*

E00506802172

The front fog lamps can be operated while the headlamps or tail lamps are on. Turn the knob in the “ON” direction to turn on the front fog lamps. An indicator lamp in the instrument cluster will also come on. Turn the knob in the “OFF” direction to turn off the front fog lamps. The knob will automatically return to its original position when you release it.

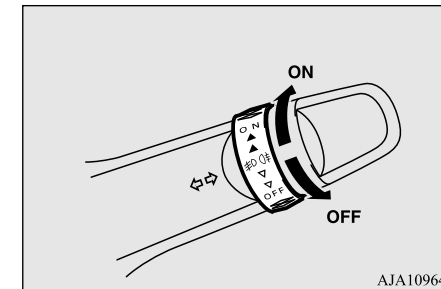

AJA109646

Wiper and washer switch

5

NOTE

- The front fog lamps are automatically turned off when the headlamps or tail lamps are turned off. To turn the front fog lamps on again, turn the knob in the “ON” direction after turning on the headlamps or tail lamps.
- Do not use fog lamps except in conditions of fog, otherwise excessive lamp glare may temporarily blind oncoming vehicle drivers.

Wiper and washer switch

E00507102882

The windscreen wipers and washer can be operated with the ignition switch or the operation mode in ON or ACC.

If the blades are frozen to the windscreen or rear window, do not operate the wipers until the ice has melted and the blades are freed, otherwise the wiper motor may be damaged.

CAUTION

- If the washer is used in cold weather, the washer fluid sprayed against the glass may freeze, which may hinder visibility. Warm the glass with the defroster before using the washer.

Windscreen wipers

E00516902323

NOTE

- To ensure a clear rearward view, the rear window wiper will automatically perform several continuous operations if the selector lever is put in the “R” (REVERSE) position while the windscreen wipers are operating. Refer to “Rear window wiper and washer” on page 5-43.

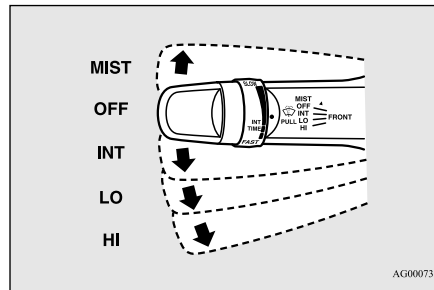

- MIST- Misting function
The wipers will operate once.
- OFF- Off
- INT- Intermittent (Speed sensitive)
- LO- Slow
- HI- Fast

To adjust intermittent intervals

With the lever in the “INT” (speed sensitive) position, the intermittent intervals can be adjusted by turning the knob (A).

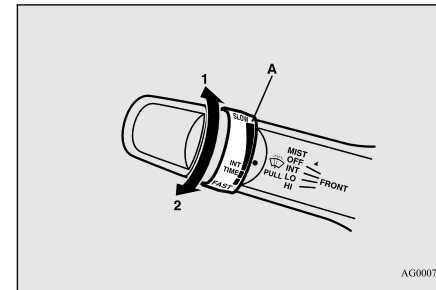

- 1- Fast
2- Slow

NOTE

- The speed-sensitive-operation function of the windscreen wipers can be deactivated. For further information, please contact an authorised MITSUBISHI MOTORS dealer.

Misting function

Move the lever in the direction of the arrow and release, to operate the wipers once. Use this function when you are driving in mist or drizzle.

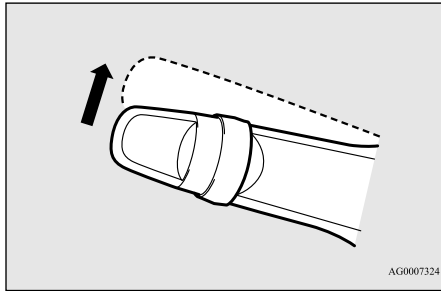

AG0007324

Windscreen washer

E00507202968

The washer fluid will be sprayed onto the windscreen by pulling the lever towards you. The wipers operate automatically several times while the washer fluid is being sprayed.

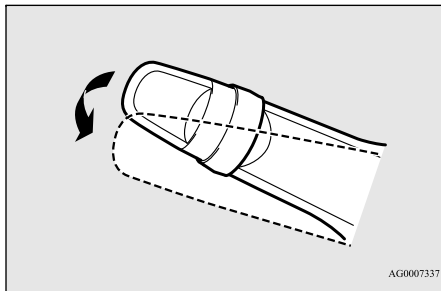

AG0007337

CAUTION

- If the washer is used in cold weather, the washer fluid sprayed against the glass may freeze resulting in poor visibility. Heat the glass with the defroster or demister before using the washer.

NOTE

- The wipers' operation combined with spraying the washer fluid can be deactivated. For more details, consult an authorised MITSUBISHI MOTORS dealer.

Rear window wiper and washer

E00507302813

The rear window wiper and washer switch can be operated with the ignition switch or the operation mode in ON or ACC.

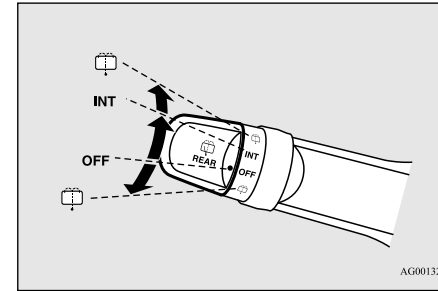

AG0013257

5

INT - The wiper operates continuously for several seconds then operates intermittently at intervals of approximately every 8 seconds.

OFF - Off

 - The washer fluid will be sprayed onto the rear window when the knob is turned fully in either direction.

The wipers operate automatically several times while the washer fluid is being sprayed.

Rear window demister switch

5

NOTE

- The rear window wiper will automatically perform several continuous operations if the selector lever is put in the “R” (REVERSE) position while the windscreen wipers or the rear window wiper is operating. (automatic operation mode)
After the automatic operation, the rear window wiper will stop operating if the knob is in the “OFF” position. If the knob is in the “INT” position, the rear window wiper will return to the intermittent operation.
It is possible to set the rear window wiper to perform the automatic operation only if the selector lever is put in the “R” (REVERSE) position while the rear window wiper is operating with the knob in the “INT” position.
For further information, please contact an authorised MITSUBISHI MOTORS dealer.
- If the knob is in the “OFF” position, turn the knob to the “INT” position twice quickly to operate the rear window wiper continuously. (continuous operation mode)
Turn the knob to the “OFF” position to stop the rear window wiper continuous operation.
- The interval for intermittent operation can be adjusted.
For further information, please contact an authorised MITSUBISHI MOTORS dealer.

Precautions to observe when using wipers and washers

E00507601688

- If the moving wipers become blocked partway through a sweep by ice or other deposits on the glass, the wipers may temporarily stop operating to prevent the motor from overheating. In this case, park the vehicle in a safe place, turn the ignition switch to the “LOCK” position or put the operation mode in OFF, and then remove the ice or other deposits. Because the wipers will start operating again after the wiper motor cools down, check that the wipers operate before using them.
- Do not use the wipers when the glass is dry.
They may scratch the glass surface and the blades wear out prematurely.
- Before using the wipers in cold weather, check that the wiper blades are not frozen onto the glass. The motor may burn out if the wipers are used with the blades frozen onto the glass.
- Avoid using the washer continuously for more than 20 seconds. Do not operate the washer when the fluid reservoir is empty. Otherwise, the motor may burn out.
- Periodically check the level of washer fluid in the reservoir and refill if required.

During cold weather, add a recommended washer solution that will not freeze in the washer reservoir. Failure to do so could result in loss of washer function and frost damage to the system components.

Rear window demister switch

E00507903092

The rear window demister switch can be operated when the engine is running. Press the switch to turn on the rear window demister. It will be turned off automatically in approximately 20 minutes. To turn off the demister within approximately 20 minutes, press the switch again. The indicator lamp (A) will illuminate while the demister is on.

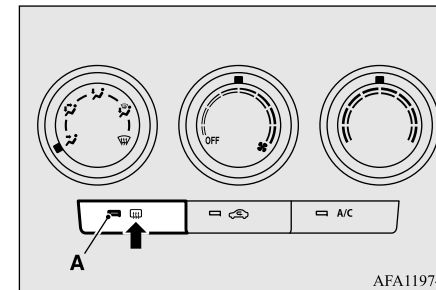

NOTE

- The demister switch is not to melt snow but to clear mist. Remove snow before use of the demister switch.
- To avoid unnecessary discharge of the battery, do not use the rear window demister during starting of the engine or when the engine is not running. Turn the demister off immediately after the window is clear.
- When cleaning the inside of the rear window, use a soft cloth and wipe gently along the heater wires, being careful not to damage the wires.
- Do not allow objects to touch the inside of the rear window glass, damaged or broken wires may result.

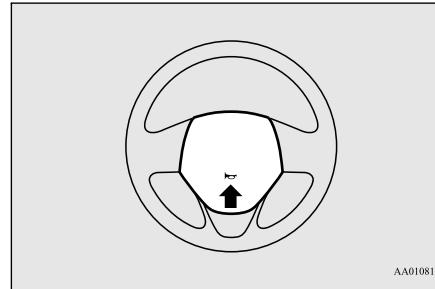
**5****Horn switch**

E00508001852

Press the steering wheel on or around the “” mark.



Starting and driving

Economical driving	6-2
Driving, alcohol and drugs	6-3
Safe driving techniques	6-3
Running-in recommendations	6-4
Parking brake	6-4
Parking	6-5
Steering wheel height and reach adjustment	6-6
Inside rear-view mirror	6-7
Outside rear-view mirrors	6-8
Ignition switch*	6-10
Engine switch*	6-11
Steering wheel lock	6-13
Starting and stopping the engine	6-15
4-speed automatic transmission	6-19
Braking	6-25
Hill start assist	6-26
Brake assist system	6-28
Emergency stop signal system	6-28
Anti-lock brake system (ABS)	6-29
Electric power steering system (EPS)	6-31
Active stability control (ASC)	6-32
Cruise control*	6-34
Rear-view camera*	6-39
Cargo loads	6-41

Economical driving

E00600102679

For economical driving, there are some technical requirements that have to be met. The prerequisite for low fuel consumption is a properly adjusted engine. In order to achieve longer life of the vehicle and the most economical operation, have the vehicle Serviced by an authorised MITSUBISHI MOTORS dealer at regular intervals in accordance with the service standards.

Fuel economy and generation of exhaust gas and noise are highly influenced by personal driving habits as well as the particular operating conditions. The following points should be observed in order to minimize wear of brakes, tyres and engine as well as to reduce environmental pollution.

Accelerating and decelerating

Drive according to traffic conditions, and avoid sudden starts, sudden acceleration, and sudden braking, as they will increase fuel consumption.

Shifting

Shift only at an appropriate speed and engine speed. Always use the highest shift position possible.

City traffic

Frequent starting and stopping increases the average fuel consumption. Use roads with smooth traffic flow whenever possible. When driving on congested roads, avoid use of a low shift position at high engine speeds.

Idling

The vehicle consumes fuel even during idling. Avoid extended idling whenever possible.

Speed

At higher the vehicle speed, more fuel is consumed. Avoid driving at full speed. Even a slight release of the accelerator pedal will save a significant amount of fuel.

Tyre inflation pressure

Check the tyre inflation pressures at regular intervals. Low tyre inflation pressure increases road resistance and fuel consumption. In addition, low tyre pressures adversely affect tyre wear and driving stability.

Cargo loads

Do not drive with unnecessary articles in the luggage compartment. Especially during city driving where frequent starting and stopping is necessary, the increased weight of the vehicle will greatly affect fuel consumption. Also avoid driving with unnecessary luggage or carriers, etc., on the roof; the increased air resistance will increase fuel consumption.

Cold engine starting

Starting of a cold engine consumes more fuel. Unnecessary fuel consumption is also caused by keeping a hot engine running. After the engine is started, commence driving as soon as possible.

Air conditioning

The use of the air conditioner will increase the fuel consumption.

Driving, alcohol and drugs

E00600201211

Drunk driving is one of the most frequent causes of accidents.

Your driving ability can be seriously impaired even with blood alcohol levels far below the legal minimum. If you have been drinking, don't drive. Ride with a designated non-drinking driver, call a cab or a friend, or use public transportation. Drinking coffee or taking a cold shower will not make you sober.

Similarly, prescription and nonprescription drugs affect your alertness, perception and reaction time. Consult with your doctor or pharmacist before driving while under the influence of any of these medications.

WARNING

- **NEVER DRINK AND DRIVE.**
Your perceptions are less accurate, your reflexes are slower and your judgment is impaired.

Safe driving techniques

E00600301935

Driving safety and protection against injury cannot be fully ensured. However, we recommend that you pay extra attention to the following:

Seat belts

Before starting the vehicle, make sure that you and your passengers have fastened your seat belts.

Floor mats

WARNING

- **Keep floor mats clear of the pedals by correctly laying floor mats that are suitable for the vehicle.**
To prevent the floor mats from slipping out of position, securely retain them using the hook etc.
Note that laying a floor mat over a pedal or laying one floor mat on top of another can obstruct pedal operation and lead to a serious accident.

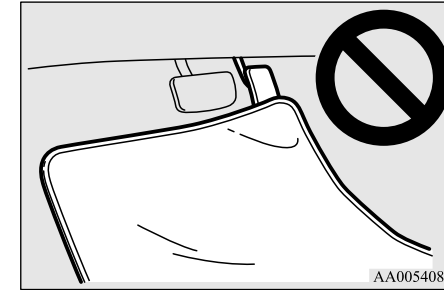

AA0054085

6

Carrying children in the vehicle

- Never leave your vehicle unattended with the key and children inside the vehicle. Children may play with the driving controls and this could lead to an accident.
- Make sure that infants and small children are properly restrained in accordance with the laws and regulations, and for maximum protection in case of an accident.
- Prevent children from playing in the luggage compartment. It is quite dangerous to allow them to play there while the vehicle is moving.

Loading luggage

When loading luggage, be careful not to load above the height of seats. This is dangerous

Running-in recommendations

not only because rearward vision will be obstructed, but also the luggage may be projected into the passenger compartment under hard braking.

Running-in recommendations

E00600404764

6

During the running-in period for the first 1,000 km, it is advisable to drive your new vehicle using the following precautions as a guideline to aid long life as well as future economy and performance.

- Do not race the engine at high speeds.
- Avoid rapid starting, accelerating, braking and prolonged high-speed running.
- Keep to the running-in speed limit shown below.
Please note that the legal speed limits displayed must be adhered to.
- Do not exceed loading limits.
- Refrain from towing a trailer.

Shift point	Speed limit
“L” (LOW)	30 km/h
“2” (SECOND)	60 km/h
“D” (DRIVE)* ¹	100 km/h
“D” (DRIVE)* ²	105 km/h

6-4 Starting and driving

*¹: With overdrive switched OFF

*²: With overdrive switched ON

Parking brake

E00600502976

To park the vehicle, first bring it to a complete stop, fully apply the parking brake sufficiently to hold the vehicle.

To apply

E0065020059

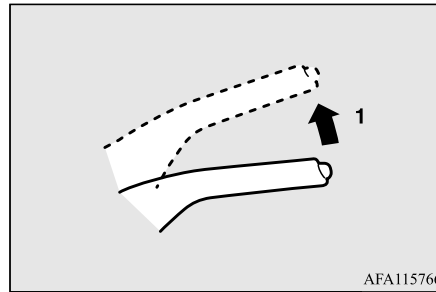

AFA115766

- 1- Firmly depress and hold the brake pedal, then pull the lever up without pressing the button at the end of hand grip.

CAUTION

- Normally, When you intend to apply the parking brake, firmly depress the brake pedal to bring the vehicle to a complete stop before pulling the parking brake lever. Pulling the parking brake lever with the vehicle moving could make the rear wheels lock up, thereby making the vehicle unstable. It could also make the parking brake malfunction.

NOTE

- Apply sufficient force to the parking brake lever to hold the vehicle stationary after the foot brake is released.
- If the parking brake does not hold the vehicle stationary after the foot brake is released, contact an authorised MITSUBISHI MOTORS dealer.

To release

E00650300063

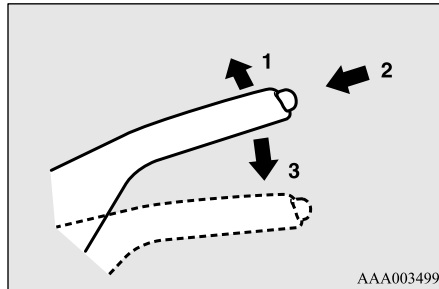

AAA003499

- 1- Firmly depress and hold the brake pedal, then pull the lever up slightly.
- 2- Press the button at the end of hand grip.
- 3- Lower the lever fully.

CAUTION

- Before driving, be sure that the parking brake is fully released and brake warning lamp is off. If you drive without the parking brake fully released, the warning display will appear on the information screen in the multi-information display and a buzzer sound when the vehicle speed exceeds a certain speed. If a vehicle is driven without releasing the parking brake, the brake will be overheated, resulting in ineffective braking and possible brake failure and rear axle damage.

Warning lamp



Warning display

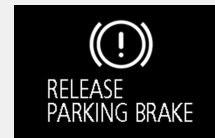

- If the brake warning lamp does not extinguish when the parking brake is fully released, the brake system may be abnormal. Contact an authorised MITSUBISHI MOTORS dealer. For details, refer to “Brake warning lamp” on page 5-34.

NOTE

- To prevent the parking brake from being released unintentionally, the lever must be pulled up slightly before it can be pushed down. Simply pressing the button does not enable the lever to be pushed down.

Parking

E00600602951

6

To park the vehicle, firmly apply the parking brake, and then set the selector lever to “P” (PARK) position.

Parking on a hill

To prevent the vehicle from rolling, follow these procedures:

Parking on a downhill slope

Turn the front wheels towards the kerb and move the vehicle forward until the kerb side wheel gently touches the kerb. Apply the parking brake and place the selector lever into the “P” (PARK) position. If necessary, apply chocks to wheels.

Steering wheel height and reach adjustment

Parking on an uphill slope

Turn the front wheels away from the kerb and move the vehicle back until the kerb side wheel gently touches the kerb.

Apply the parking brake and place the selector lever into the "P" (PARK) position.

If necessary, apply chocks to wheels.

6

NOTE

- Be sure to apply the parking brake before moving selector lever to the "P" (PARK) position. If you move selector lever to the "P" (PARK) position before applying the parking brake, it may be difficult to disengage selector lever from the "P" (PARK) position when next you drive the vehicle, requiring application of a strong force the selector lever to move from the "P" (PARK) position.

Parking with the engine running

Never leave the engine running while you take a short sleep/rest. Also, never leave the engine running in a closed or poorly ventilated place.

WARNING

- Leaving the engine running risks injury or death from accidentally moving the selector lever or the accumulation of toxic exhaust fumes on the passenger compartment.

Where you park

WARNING

- Do not park your vehicle in areas where combustible materials such as dry grass or leaves can come in contact with a hot exhaust, since a fire could occur.

Do not keep the steering wheel fully turned for a long time

More effort could be required to turn the steering wheel.

Refer to "Electric power steering system (EPS)" on page 6-31.

When leaving the vehicle

Always carry the key and lock all doors when leaving the vehicle unattended.

Always try to park your vehicle in a well lit area.

Steering wheel height and reach adjustment

E00600701740

1. Release the lever while holding the steering wheel up.
2. Adjust the steering wheel to the desired position.
3. Securely lock the steering wheel by pulling the lever fully upward.

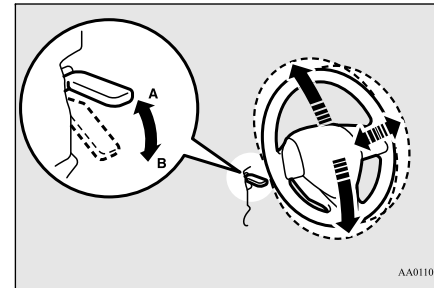

AA0110800

- A- Locked
B- Release

WARNING

- Do not attempt to adjust the steering wheel while you are driving the vehicle.

Inside rear-view mirror

E00600802243

Adjust the rear-view mirror only after making any seat adjustments so you have a clear view to the rear of the vehicle.

⚠ WARNING

- Do not attempt to adjust the rear-view mirror while driving. This can be dangerous. Always adjust the mirror before driving.

Adjust the rear-view mirror to maximize the view through the rear window.

To adjust the vertical mirror position

It is possible to move the mirror up and down to adjust its position.

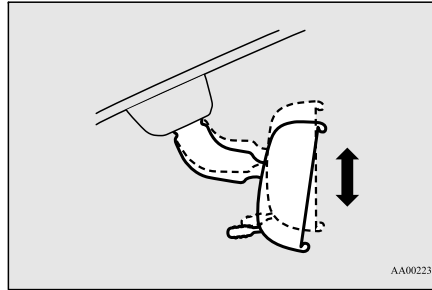

To adjust the mirror position

It is possible to move the mirror up/down and left/right to adjust its position.

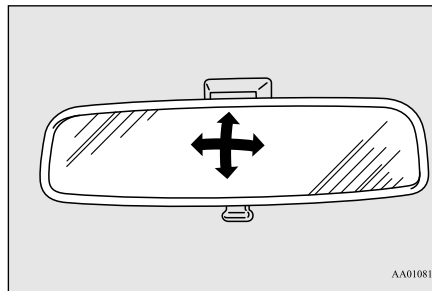

To reduce the glare

The lever (A) at the bottom of the mirror can be used to adjust the mirror to reduce the glare from the headlamps of vehicles behind you during night driving.

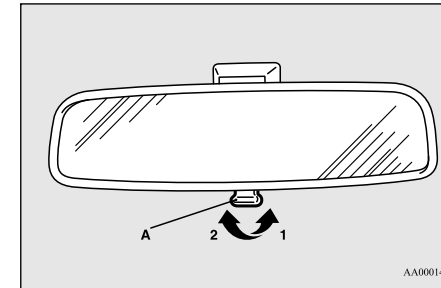

- 1- Normal
- 2- Anti-glare

6

Outside rear-view mirrors

E00600901898

To adjust the mirror position

E00601002242

WARNING

- Do not attempt to adjust the rear-view mirrors while driving. This can be dangerous. Always adjust the mirrors before driving.
- Your vehicle is equipped with convex type mirrors. Please take into consideration, but objects you see in the mirror will look smaller and farther away compared to a normal flat mirror. Do not use this mirror to estimate distance of following vehicles when changing lanes.

6

Electric remote-controlled outside rear-view mirrors

The outside rear-view mirrors can be operated when the ignition switch is in the "ON" or "ACC" position or the operation mode is put in ON or ACC.

1. Push the switch (A) to the same side as the mirror whose adjustment is desired.

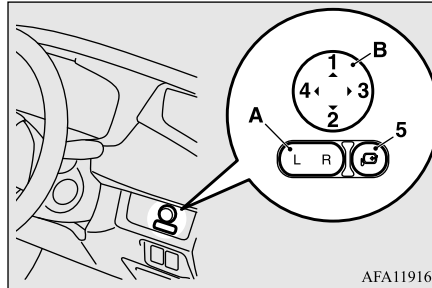

AFA119168

- L- Left outside mirror adjustment
- R- Right outside mirror adjustment

2. Press the switch (B) to the left, right, up or down to adjust the mirror position.

- 1- Up
- 2- Down
- 3- Right
- 4- Left
- 5- Mirror retractor switch

3. After completing the adjustment, return the switch (A) to the centre position.

Retracting and extending the outside mirrors

E00601102676

The outside mirror can be retracted in towards the side window to prevent damage when parking in narrow areas.

CAUTION

- Do not drive the vehicle with the mirror retracted. The lack of rearward visibility normally provided by the mirror could lead to an accident.

Retracting and extending the mirrors using the mirror retractor switch

With the ignition switch or the operation mode in ON or ACC, press the mirror retractor switch to retract the mirrors.

Press it again to extend the mirrors to their original positions.

After turning the ignition switch to the "LOCK" position or putting the operation mode in OFF, it is possible to retract and extend the mirrors using the mirror retractor switch for approximately 30 seconds.

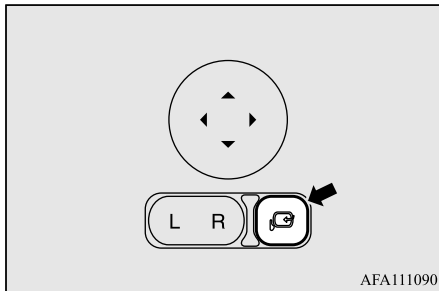

CAUTION

- It is possible to retract and extend the mirrors by hand. After retracting a mirror using the mirror retractor switch, however, you should extend it by using the switch again, not by hand. If you extended the mirror by hand after retracting it using the switch, it would not properly lock in position. As a result, the mirror could move because of the wind or vibration while you are driving, and this may prevent the driver's rearward visibility.

NOTE

- Be careful not to get your hands trapped while a mirror is moving.

NOTE

- If you move a mirror by hand or it moves after hitting a person or object, you may not be able to return it to its original position using the mirror retractor switch. If this happens, push the mirror retractor switch to place the mirror in its retracted position and then push the switch again to return the mirror to its original position.
- When freezing has occurred and mirrors fail to operate as intended, please refrain from repeated pushing of the retractor switch as this action can result in burn-out of the mirror motor circuits.

Retracting and extending the mirrors without using the mirror retractor switch

[Except for vehicles equipped with keyless operation system]
 The mirrors automatically retract or extend when the doors and tailgate are locked or unlocked using the key switches of the keyless entry system.
 Refer to "Keyless entry system" on page 3-4.
 [Vehicles with the keyless operation system]
 The mirrors automatically retract or extend when the doors and tailgate are locked or unlocked using the key switches or the keyless operation function of the keyless operation system.

Refer to "Keyless entry system" on page 3-4.
 Refer to "Keyless operation system: To operate using the keyless operation function" on page 3-9.

NOTE

- Functions can be modified as stated below. Please consult an authorised MITSUBISHI MOTORS dealer.
 - Automatically extend when the driver's door is closed and the ignition switch is turned to the "ON" position or the operation mode is put in ON.
 In addition, automatically retract when the ignition switch is turned to the "LOCK" or "ACC" position or the operation mode is put in OFF or ACC, and the driver's door is then opened.
 - Automatically extend when the vehicle speed reaches approximately 30 km/h.
 - Deactivate the automatic extension function.

Ignition switch*

6

NOTE

The outside rear-view mirrors can be retracted or extended by the following operations, even if changing to the any of above.

After pressing the LOCK switch on the key to lock the doors and tailgate, if the LOCK switch is pressed again twice in a row within approximately 30 seconds, the outside rear-view mirrors will retract.

After pressing the UNLOCK switch on the key to unlock the doors and tailgate, if the UNLOCK switch is pressed again twice in a row within approximately 30 seconds, the outside rear-view mirrors will extend again.

Ignition switch*

E00601403432

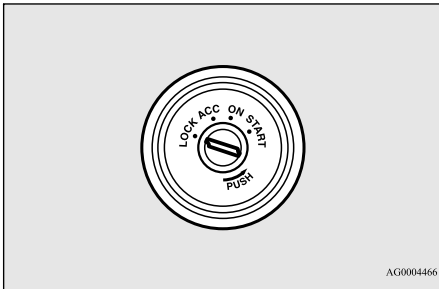

LOCK

The engine is stopped and the steering wheel locked. The key can only be inserted and removed in this position.

ACC

The engine is stopped, but the audio system and other electric devices can be operated.

ON

All the vehicle's electrical devices can be operated.

START

The starter motor operates. After the engine has started, release the key and it will automatically return to the "ON" position.

NOTE

- Your vehicle is equipped with an electronic immobilizer.

To start the engine, the ID code which the transponder inside the key sends must match the one registered in the immobilizer computer.

Refer to "Electronic immobilizer (Anti-theft starting system)" on page 3-3.

To remove the key

E00620401727

When removing the key, first set the selector lever to the "P" (PARK) position, and push the key in at the "ACC" position and keep it depressed until it is turned to the "LOCK" position, and remove it.

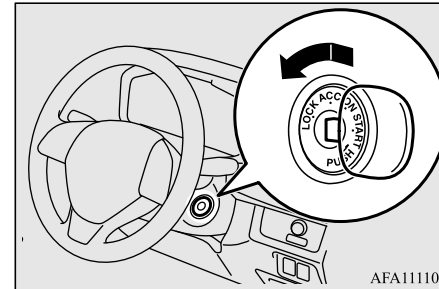

⚠ CAUTION

- Do not remove the ignition key from the ignition switch while driving. The steering wheel will be locked, causing loss of control.
- If the engine is stopped while driving, the brake servomechanism will cease to function and braking efficiency will deteriorate. Also, the power steering system will not function and it will require greater manual effort to operate the steering.
- Do not leave the key in the “ON” position for a long time when the engine is not running, doing so will cause the battery to be discharged.
- Do not turn the key to the “START” position while the engine is running. Doing so could damage the starter motor.

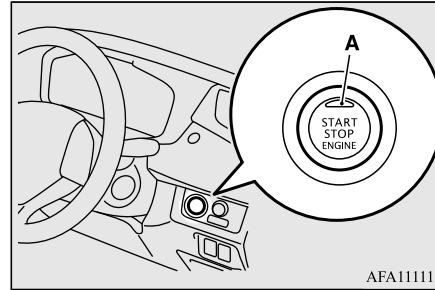

⚠ CAUTION

- The indicator lamp (A) will flash orange when there is a problem or malfunction in the keyless operation system. Never drive if the indicator lamp on the engine switch is flashing orange. Immediately contact an authorised MITSUBISHI MOTORS dealer.
- If the engine switch operation is not smooth and feels like it is sticking, do not operate the switch. Immediately contact an authorised MITSUBISHI MOTORS dealer.

📖 NOTE

- When operating the engine switch, press the switch all the way in. If the switch is not fully pressed, the engine may not start or the operation mode may not change. If the engine switch is pressed correctly, there is no need to hold the engine switch down.

Engine switch*

E00631801822

In order to prevent theft, the engine will not start unless a preregistered keyless operation key is used. (Engine immobilizer function)
If you are carrying the keyless operation key, you can start the engine.

📖 NOTE

- When the battery in the keyless operation key has worn out, or the keyless operation key is out of the vehicle, warning display will appear.
Warning display (when the engine switch is pressed 1 time)

KEY NOT DETECTED

Warning display (when the engine switch is pressed 2 times or more)

KEY NOT DETECTED
TOUCH SWITCH
WITH KEY

6

Operation mode of the engine switch and its function

OFF

The indicator lamp on the engine switch turns off.
The operation mode cannot be put in OFF when the selector lever is in any position other than the “P” (PARK) position.

Engine switch*

ACC

Electrical devices such as the audio and accessory socket can be operated.

The indicator lamp on the engine switch illuminates orange.

ON

6 All vehicle's electrical devices can be operated.

The indicator lamp on the engine switch illuminates green. The indicator lamp turns off when the engine is running.

NOTE

- Your vehicle is equipped with an electronic immobilizer. To start the engine, the ID code which the transponder inside the key sends must match the one registered in the immobilizer computer. Refer to "Electronic immobilizer (Anti-theft starting system)" on page 3-3.

Changing the operation mode

E00631901692

If you press the engine switch without depressing the brake pedal, you can change the operation mode in the order of OFF, ACC, ON, OFF.

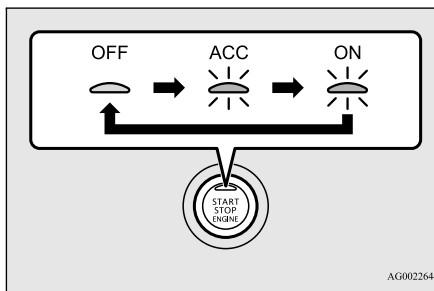

CAUTION

- When the engine is not running, put the operation mode in OFF. Leaving the operation mode in ON or ACC for a long time when the engine is not running may cause the battery to be discharged, making it impossible to start the engine, lock and unlock the steering wheel.
- When the battery is disconnected, the current operation mode is memorized. After reconnecting the battery, the memorized mode is selected automatically. Before disconnecting the battery for repair or replacement, make sure to put the operation mode in OFF. Be careful if you are not sure which operation mode the vehicle is in when the battery is run down.

CAUTION

- The operation mode cannot be changed from OFF to ACC or ON if the keyless operation key is not detected to be in the vehicle. Refer to "Keyless operation system: Operating range for starting the engine and changing the operation mode" on page 3-9.
- When there is the keyless operation key in the vehicle and the operation mode isn't change, the keyless operation key battery may have worn out.

NOTE

- If the operation mode cannot be changed to OFF, perform the following procedure.
 1. Move the selector lever to the "P" (PARK) position, and then change the operation mode to OFF.
 2. One of the other causes could be low battery voltage. If this occurs, the keyless entry system, keyless operation function, and steering lock will also not operate. Contact an authorised MITSUBISHI MOTORS dealer.

ACC power auto-cutout function

E00632801744

After approximately 30 minutes has elapsed with the operation mode in ACC, the function automatically cuts out the power for the audio

system and other electric devices that can be operated with that position. {only that driver's door has closed and the selector lever in the "P" (PARK) position}

When you open driver's door or the engine switch operate again, the power is supplied again.

NOTE

- When the ACC power is automatically cut out, you cannot lock the steering wheel and you cannot lock and unlock the doors using the keyless entry system or keyless operation function.
 - It is possible to modify functions as follows:
 - The time until the power cuts out can be changed to approximately 60 minutes.
 - The ACC power auto-cutout function can be deactivated.
- For details, consult an authorised MITSUBISHI MOTORS dealer.

Operation mode OFF reminder system

E00632201692

Warning display



When the operation mode is in any mode other than OFF, if you try to lock the doors and the tailgate by pressing the driver's or front passenger's door lock/unlock switch, or the tailgate lock/unlock switch, warning display will appear and the outer buzzer will sound and you cannot lock the doors.

Operation mode ON reminder system

E00632301185

If the driver's door is opened with the engine stopped and the operation mode in any mode other than OFF, the operation mode ON reminder inner buzzer sounds intermittently to remind you to put the operation mode in OFF.

Warning display



Steering wheel lock

E00601502508

Except for vehicles equipped with the keyless operation system

To lock

Remove the key at the "LOCK" position. Turn the steering wheel until it is locked.

6

To unlock

Turn the key to the "ACC" position while moving the steering wheel slightly right and left.

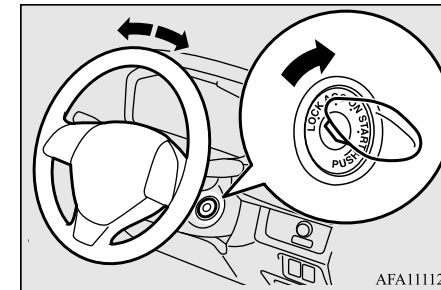

AFA111120

Steering wheel lock

CAUTION

- Remove the key when leaving the vehicle. In some countries, it is prohibited to leave the key on the vehicle when parked.

For vehicles equipped with the keyless operation system

6 To lock

After pressing the engine switch and operation mode in OFF, when driver's door is opened, the steering wheel is locked.

CAUTION

- If the engine is stopped while driving, do not open a door or press the LOCK switch on the key until the vehicle stops in a safe place. This could cause the steering wheel to lock, making it impossible to operate the vehicle.

NOTE

- When the following operation is performed with the operation mode in OFF and the selector lever is in the "P" (PARK) position, the steering wheel is locked.
 - Open or close the driver's door.
 - Close all the doors and the tailgate.
 - Open one of the doors or the tailgate when all the doors and the tailgate are closed.

NOTE

- Lock all the doors and the tailgate with the keyless entry system or the keyless operation system function.
- When the driver's door is opened while the steering wheel does not lock, warning display will appear and the inner buzzer sounds to alert the steering wheel is unlocked.



To unlock

The following methods can be used to unlock the steering wheel.

- Put the operation mode in ACC.
- Start the engine.

CAUTION

- Carry the key with you when leaving the vehicle.
- If your vehicle needs to be towed, unlock the steering wheel. Refer to "Towing: Emergency towing" on page 8-13.

NOTE

- When the steering wheel does not unlock, the warning display will appear and the inner buzzer will sound. Press the engine switch again while moving the steering wheel slightly right and left.

Warning display



- If there is a fault in the steering wheel lock and the steering wheel cannot be locked, the warning display will appear and the inner buzzer will sound. Change the operation mode from ON to OFF and trying to lock the steering wheel again. If the warning display appears again, have your vehicle checked at an authorised MITSUBISHI MOTORS dealer.

Warning display



NOTE

- If there is a fault in the steering wheel lock, the warning display will appear and the inner buzzer will sound. Immediately stop the vehicle in a safe place and contact the nearest authorised MITSUBISHI MOTORS dealer.

Warning display



STEERING LOCK SERVICE REQUIRED

Starting and stopping the engine

E00620601628

Tips for starting

Except for vehicles equipped with the keyless operation system

- Do not operate the starter motor continuously longer than 10 seconds; doing so could run down the battery. If the engine does not start, turn the ignition switch back to “LOCK”, wait a few seconds, and then try again. Trying repeatedly with the starter motor still turning will damage the starter mechanism.

WARNING

- **Never run the engine in a closed or poorly ventilated area any longer than is needed to move your vehicle in or out of the area. Carbon monoxide gases are odourless and can be fatal.**

CAUTION

- Never attempt to start the engine by pushing or pulling the vehicle.

CAUTION

- Do not run the engine at high speeds or drive the vehicle at high speeds until the engine has had a chance to warm up.
- Release the ignition key as soon as the engine starts to avoid damaging the starter motor.

For vehicles equipped with the keyless operation system

- The operation mode can be in any mode to start the engine.
- The starter motor will be turning for up to approximately 15 seconds if the engine switch is released at once. Pressing the engine switch again while the starter motor is still turning will stop the starter motor. The starter motor will be turning for up to approximately 30 seconds while the engine switch is pressed.

If the engine does not start, wait for a while and then attempt to start the engine again. Trying repeatedly with the starter motor still turning will damage the starter mechanism.

Starting and stopping the engine

WARNING

- Never run the engine in a closed or poorly ventilated area any longer than is needed to move your vehicle in or out of the area. Carbon monoxide gases are odourless and can be fatal.

CAUTION

- Never attempt to start the engine by pushing or pulling the vehicle.
- Do not run the engine at high speeds or drive the vehicle at high speeds until the engine has had a chance to warm up.

6

Starting the engine

E00620702192

Except for vehicles equipped with the keyless operation system

The starting procedure is as follows:

1. Insert the ignition key and fasten the seat belt.
2. Make sure the parking brake is applied.
3. Depress and hold the brake pedal.
4. Make sure the selector lever is in the “P” (PARK) position.

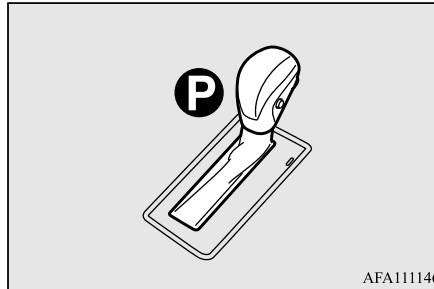

NOTE

- The starter will not operate unless the selector lever is in the “P” (PARK) or “N” (NEUTRAL) position. For safety reasons, start the engine in the “P” (PARK) position so that the wheels are locked.

5. After turning the ignition switch to the “ON” position, make certain that all warning lamps are functioning properly before starting the engine.
6. Turn the ignition switch to the “START” position without depressing the accelerator pedal, and release it when the engine starts.

NOTE

- Minor noises may be heard on engine start-up. These will disappear as the engine warms up.

When the engine is hard to start

After several attempts, you may experience that the engine still does not start.

1. Make sure that all electric devices, such as lamps, air conditioning blower and rear window demister, are turned off.
2. While depressing the brake pedal, press the accelerator pedal halfway and hold it there, then crank the engine. Release the accelerator pedal, immediately after the engine starts.

- If the engine still will not start, the engine could be flooded with too much petrol. While depressing the brake pedal, press the accelerator pedal all the way down and hold it there, then crank the engine for 5 to 6 seconds. Return the ignition switch to the "LOCK" position and release the accelerator pedal. Wait a few seconds, and then crank the engine again for 5 to 6 seconds while depressing the brake pedal, but do not press the accelerator pedal. Release the ignition switch if the engine starts. If the engine fails to start, repeat these procedures. If the engine still will not start, contact an authorised MITSUBISHI MOTORS dealer.

For vehicles equipped with the keyless operation system

The starting procedure is as follows:

- Fasten the seat belt.
- Make sure the parking brake is applied.
- Press and hold the brake pedal down firmly with your right foot.

NOTE

- When the engine is not started, it may become hard to depress the brake pedal and the vehicle may not be able to detect the pedal operation. Therefore the engine may not be started. In such a case, depress the brake pedal more firmly than usual.

- Make sure the selector lever is in the "P" (PARK) position.

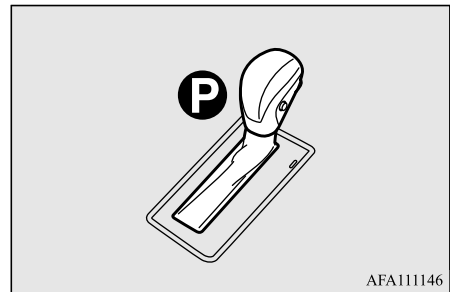

- Press the engine switch.
- Make certain that all warning lamps are functioning properly.

NOTE

- Minor noises may be heard on engine start-up. These will disappear as the engine warms up.

NOTE

- When starting the engine, the selector lever is in a position other than the "P" (PARK) or the "N" (NEUTRAL) position, or you pressed the engine switch without depressing the brake pedal, warning display will appear.

Warning display

When the engine is hard to start

After several attempts, you may experience that the engine still does not start.

- Make sure that all electric devices, such as lamps, air conditioning blower and rear window demister, are turned off.
- While depressing the brake pedal, press the accelerator pedal halfway and hold it there, then crank the engine. Release the accelerator pedal, immediately after the engine starts.

Starting and stopping the engine

6

3. If the engine still will not start, the engine could be flooded with too much petrol. While depressing the brake pedal, press the accelerator pedal all the way down and hold it there, then press the engine switch to crank the engine. If the engine does not start after 5 to 6 seconds, press the engine switch to stop the engine, and release the accelerator pedal. Put the operation mode in OFF. Wait a few seconds, and then press the engine switch to crank the engine again while depressing the brake pedal, but do not press the accelerator pedal. If the engine fails to start, repeat these procedures. If the engine still will not start, contact an authorised MITSUBISHI MOTORS dealer.

Stopping the engine

E00620801633

Except for vehicles equipped with the keyless operation system

1. Bring the vehicle to a complete stop.
2. Firmly apply the parking brake while depressing the brake pedal.
3. Place the selector lever in the "P" (PARK) position, and stop the engine.

For vehicles equipped with the keyless operation system

⚠ WARNING

- Do not operate the engine switch while driving except in an emergency. If the engine is stopped while driving, the brake servomechanism will cease to function and braking efficiency will deteriorate. Also, the power steering system will not function and it will require greater manual effort to operate the steering. This could result in a serious accident.

📖 NOTE

- If you have to bring the engine to an emergency stop while driving, press and hold the engine switch for 3 seconds or more, or press it quickly 3 times or more. The engine will stop and the operation mode will go to ACC.
- Do not stop the engine with the selector lever in any position other than the "P" (PARK) position. If the engine is stopped with the selector lever in any position other than the "P" (PARK) position, the operation mode will go to ACC rather than OFF. Put the operation mode in OFF after placing the selector lever in the "P" (PARK) position.

1. Stop the vehicle.

2. Firmly apply the parking brake while depressing the brake pedal.
3. Move the selector lever to the "P" (PARK) position, press the engine switch to stop the engine.

If the keyless operation key is not operating properly

E00632901455

The following operation can be used to start the engine or change the operation mode.

1. Depress the brake pedal firmly with your right foot.
2. While depressing the brake pedal, touch the portion of the keyless operation key shown in the illustration to the engine switch.

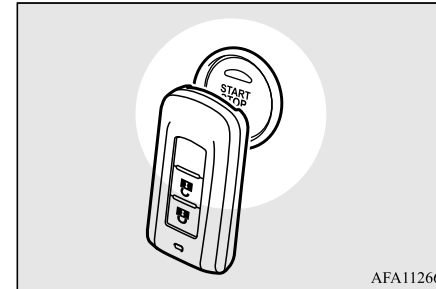

AFA112664

3. If the keyless operation key is recognized, the indication lamp on the engine switch illuminates in green, and then the engine can be started and the operation mode can be changed within approximately 10 seconds. Refer to “Starting the engine” on page 6-16 and “Changing the operation mode” on 6-12.

NOTE

- If metal objects or other keys are near the keyless operation key, the keyless operation key may not be recognized.
- Instead of depressing the brake pedal, the keyless operation key can also be recognized in the same way within approximately 30 seconds after pushing the engine switch.
- To change the operation mode without starting the engine, release the brake pedal after the indication lamp on the engine switch illuminates in green, and then press the engine switch.

4-speed automatic transmission

E00603202192

NOTE

- During running-in period or immediately after reconnection of the battery cable, there may be a case where gear shifts are not made smoothly. This does not indicate a faulty transmission. Gear shifts will become smooth after the transmission has been shifted several times by the electronic control system.

Selector lever operation

E00603302353

The transmission has 4 forward gears and 1 reverse gear. The individual gears are selected automatically, depending on the speed of the vehicle and the position of the accelerator pedal. The selector lever has 6 positions, and is equipped with a lock button (A) to avoid inadvertent selection of the wrong gear.

4-speed automatic transmission

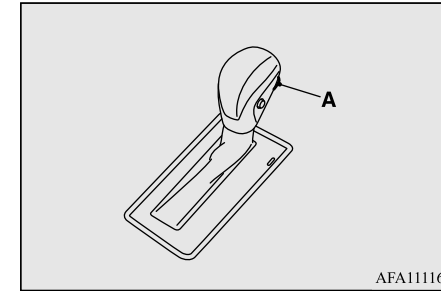

AFA111162

6

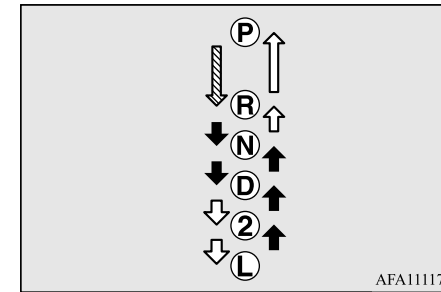

AFA111175

	The lock button must be pressed while the brake pedal is depressed to move the selector lever.
	The lock button must be pressed to move the selector lever.
	The lock button need not be pressed to move the selector lever.

⚠ WARNING

- If the lock button is always pressed to operate the selector lever, the selector lever may be accidentally shifted into the “P” (PARK), “R” (REVERSE), “2” (SECOND) or “L” (LOW) position. Be sure not to press the lock button when performing the operations indicated by ↓ in the illustration.
- Always depress the brake pedal when shifting the selector lever into a gear from the “P” (PARK) or “N” (NEUTRAL) position. Never put your foot on the accelerator pedal while shifting the selector lever from the “P” (PARK) or “N” (NEUTRAL) position.

📖 NOTE

- To avoid erroneous operation, move the selector lever firmly into each position and briefly hold it there. Always check the position shown by the selector lever position display after moving the selector lever.
- If the brake pedal is not depressed and held, the shift-lock device activates to prevent the selector lever from being moved from the “P” (PARK) position.

When the selector lever cannot be shifted from the “P” (PARK) position

E0069480026

When the selector lever cannot be shifted from the “P” (PARK) position to another position while the brake pedal is pressed and held down with the ignition switch at the “ON” position or the operation mode in ON, the battery may be flat or the shift-lock mechanism may be malfunctioning. Immediately have your vehicle checked by an authorised MITSUBISHI MOTORS dealer.

If you need to move the vehicle, shift the selector lever as follows.

1. Make sure the parking brake is fully applied.
2. Stop the engine if it is running.
3. Depress the brake pedal with the right foot.
4. Insert a straight blade (or minus) screwdriver straight into the shift-lock release hole (A).

Shift the selector lever to the “N” (NEUTRAL) position while pressing the straight blade (or minus) screwdriver down.

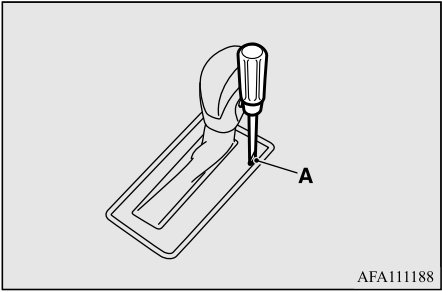

AFA111188

Selector lever position indicator display

E00603502065

When the ignition switch is turned to the “ON” position or the operation mode is put in ON, the position of the selector lever is indicated in the multi-information display.

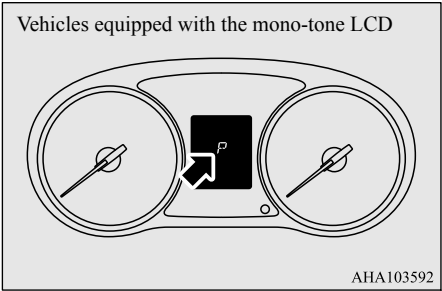

AHA103592

Vehicles equipped with the TFT colour LCD

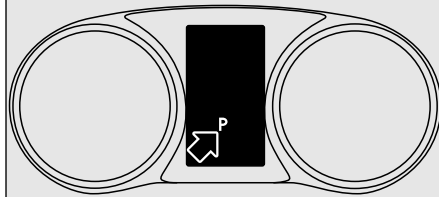

AAA057694

Selector lever positions

E00603801960

“P” PARK

This position locks the transmission to prevent the vehicle from moving. The engine can be started in this position.

“R” REVERSE

This position is to back up.

⚠ CAUTION

- Never shift into the “P” (PARK) or “R” (REVERSE) position while the vehicle is in motion to avoid a transmission damage.

“N” NEUTRAL

At this position the transmission is disengaged. It is the same as the neutral position on a M/T, and should only be used when the vehicle is stationary for an extended length of time during driving, such as in a traffic jam.

⚠ WARNING

- Never move the selector lever to the “N” (NEUTRAL) position while driving. A serious accident could occur since you could accidentally move the lever into the “P” (PARK) or “R” (REVERSE) position or you will lose engine braking.
- On a gradient, the engine should be started in the “P” (PARK) position, not in the “N” (NEUTRAL) position.
- To prevent rolling, always keep your foot on the brake pedal when the vehicle is in “N” (NEUTRAL) position, or when shifting into or out of “N” (NEUTRAL) position.

“D” DRIVE

This position is for normal driving. The transmission automatically selects a suitable gear for your speed and acceleration.

⚠ CAUTION

- To prevent transmission damage, never shift into the “D” (DRIVE) position from the “R” (REVERSE) position while the vehicle is in motion.

“2” SECOND

This position is for extra power when driving up moderately steep hills, and for engine braking when descending moderately steep gradients.

“L” LOW

This position is for driving up very steep hills and for engine braking at low speeds when driving down steep hills.

⚠ WARNING

- This position can be used for maximum engine braking. Be very careful not to shift into “L” (LOW) position suddenly. Sudden engine braking may cause the tyres to skid. Select this position according to the road conditions and vehicle speed.

6

4-speed automatic transmission

NOTE

- The A/T has a control function that prevents over-revving. As a result, it may not perform a shift when the selector lever is moved from the “D” (DRIVE) position to the “2” (SECOND) position or from the “2” (SECOND) position to the “L” (LOW) position.

6 Overdrive control switch

E00604001129

The overdrive control switch can be used while the selector lever is in the “D” (DRIVE) position.

During normal driving

Press the overdrive control switch to turn the overdrive function on. The transmission will shift automatically among the 1st, 2nd, 3rd, and 4th gears, enabling fuel-efficient, economical driving.

During hilly roads driving

Press the overdrive control switch to turn the overdrive function off. The transmission will shift automatically among the 1st, 2nd, and 3rd gears, and light engine braking will be available on downhill roads.

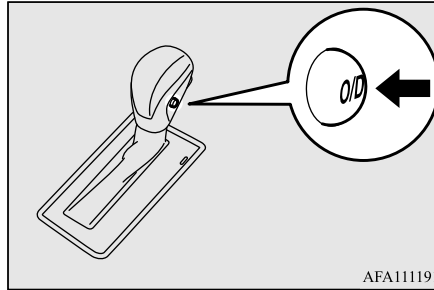

Overdrive OFF indicator lamp/overdrive OFF indicator

E00614601056

Vehicles equipped with the mono-tone LCD

When the overdrive control switch is in the OFF position, the overdrive OFF indicator lamp in the meter cluster comes on.

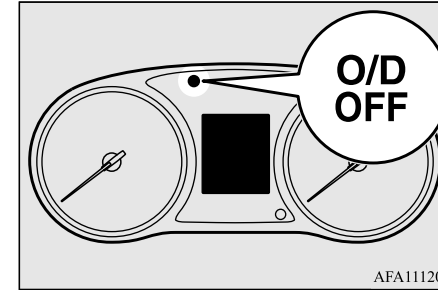

Vehicles equipped with the TFT colour LCD

When the overdrive control switch is in the OFF position, the overdrive OFF indicator appears on the multi-information display.

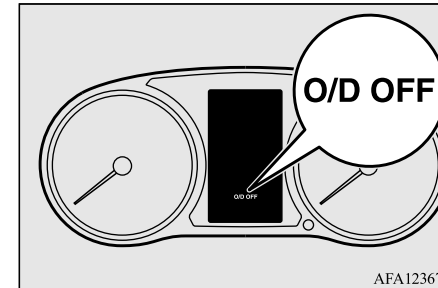

When a malfunction occurs in the A/T

E00615101579

Vehicles equipped with the monotone LCD

E00660800061

■ When the selector lever position display blinks

E00660900075

When the selector lever position display blinks while you are driving, there could be a malfunction in the A/T system or A/T fluid temperature becomes abnormally high.

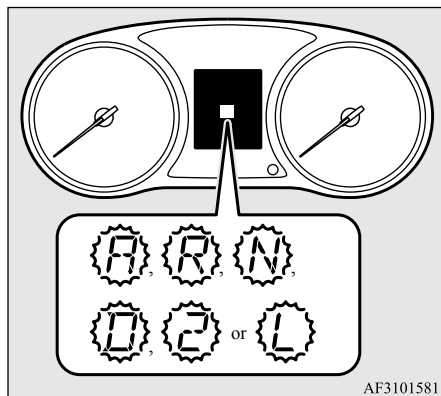

AF3101581

NOTE

- “A” indicator does blink only the condition that the A/T position switch is broken. It does not indicate in normal driving condition.

CAUTION

- If the selector lever position display blinks while you are driving, it is likely that a safety device is operating because of a malfunction in the A/T. Immediately have the vehicle inspected by an authorised MITSUBISHI MOTORS dealer.

Vehicles equipped with the TFT colour LCD

E00661100090

There could be a system malfunction if the warning display or the warning display is displayed on the information screen in the multi-information display.



■ When the warning display is displayed on

NOTE

- The buzzer may sound at the time of warning display appears.

CAUTION

- If malfunction occurs in the A/T while driving, the warning display appears on the information screen in the multi-information display. In this case, immediately park your vehicle in a safe place and follow these procedures:

The A/T fluid is overheating. The engine control may activate to lower the A/T fluid temperature, causing the engine revolutions and vehicle speed to decrease, or the gear shift timing may change by activating the A/T control. In this case, take one of the following procedures.

- Slow down your vehicle.
- Stop your vehicle in a safe place, put the selector lever in the “P” (PARK) position, and open the bonnet with the engine running to allow the engine to cool down.

6

4-speed automatic transmission

CAUTION

After a while, confirm that the  warning display is no longer showing. It is safe to continue driving if the display is no longer showing. If the warning display remains, contact an authorised MITSUBISHI MOTORS dealer immediately.

6

■ When the warning display is displayed on

NOTE

- The selector lever position display blinks at the time of  warning display appears.
- The “A” indicator on the selector lever position display will blink only when there is a problem with the A/T position switch. It is not seen during normal driving.

CAUTION

- If malfunction occurs in the A/T while driving, the  warning display appears on the information screen in the multi-information display. In this case, immediately park your vehicle in a safe place and follow these procedures:

CAUTION

It may be that there is something unusual happening in the A/T, causing a safety device to activate. Immediately have your vehicle inspected by an authorised MITSUBISHI MOTORS dealer.

Operation of the A/T

E00604201831

CAUTION

- Before selecting a gear with the engine running and the vehicle stationary, fully depress the brake pedal to prevent the vehicle from creeping. The vehicle will begin to move as soon as the gear is engaged, especially when the engine speed is high, at fast idle or with the air conditioner operating, the brakes should only be released when you are ready to drive away.
- Depress the brake pedal with the right foot at all times. Using the left foot could cause driver movement delay in case of an emergency.
- To prevent sudden acceleration, never race the engine when shifting from the “P” (PARK) or “N” (NEUTRAL) position.
- Operating the accelerator pedal while the other foot is resting on the brake pedal will affect braking efficiency and may cause premature wear of brake pads.

CAUTION

- Use the selector lever in the correct shift position in accordance with driving conditions. Never coast downhill backward with the selector lever in the {“D” (DRIVE), “2” (SECOND) or “L” (LOW)}; or coast forward with the selector lever in the “R” (REVERSE) position. The engine may stop and the unexpected increase in brake pedal effort and steering wheel weight could lead to an accident.
- Do not race the engine with brake pedal pressed when the vehicle is stationary. This can damage the A/T. Also, when you depress the accelerator pedal while holding down the brake pedal with the selector lever in the “P” (PARK), “N” (NEUTRAL), “D” (DRIVE), “2” (SECOND) or “L” (LOW) position, the engine revolutions may not rise as high as when performing the same operation with the selector lever in the “N” (NEUTRAL) position.

Passing acceleration

E00604501397

To gain extra acceleration in “D” (DRIVE) position, press the accelerator to the floor. The A/T will automatically downshift.

Waiting

E00604601415

For short waiting periods, such as at traffic signals the vehicle can be left in gear and held stationary with the service brake.

For longer waiting periods with the engine running, place the selector lever in the “N” (NEUTRAL) position and apply the parking brake, while holding the vehicle stationary with the service brake.

CAUTION

- Never hold the vehicle stationary on a hill using the accelerator pedal (without using the brake pedal). Always apply the parking brake and/or service brakes.

Parking

E00604701357

To park the vehicle, first bring it to a complete stop, firmly apply the parking brake, and then move the selector lever to the “P” (PARK) position.

If you are going to leave the vehicle unattended, always switch off the engine and carry the key.

NOTE

- On a slope, be sure to apply the parking brake before moving the selector lever to the “P” (PARK) position. If you move the selector lever to the “P” (PARK) position before applying the parking brake, it may be difficult to disengage the selector lever from the “P” (PARK) position when next you drive the vehicle, requiring application of a strong force to the selector lever to move from the “P” (PARK) position.

When the A/T makes no speed change

E00604802036

If the transmission does not change speeds while driving, or your vehicle does not pick up enough speed when starting on an uphill slope, it may be that there is something unusual happening in the transmission, causing a safety device to activate. Immediately have your vehicle checked at an authorised MITSUBISHI MOTORS dealer.

1. If your vehicle has difficulty moving uphill, shift the selector lever into 2nd gear. This method might not work depending on the transmission malfunction.

2. Once the vehicle is moving on a level road, move the selector lever back to “D” (DRIVE).

NOTE

- When the selector lever position display in the instrument panel blinks, it means that there is an abnormal condition in the transmission. Refer to “When the selector lever position display blinks” on page 6-23.

6**Braking**

E00607003225

All the parts of the brake system are critical to safety. Have the vehicle serviced by an authorised MITSUBISHI MOTORS dealer at regular intervals according to the service booklet.

CAUTION

- Avoid driving habits that cause heavy braking and never “ride” the brakes by resting your foot on the brake pedal while driving. It causes brake overheating and fade.

Brake system

The service brake is divided into two brake circuits. And your vehicle is equipped with

Starting and driving 6-25

Hill start assist

power brakes. If one brake circuit fails, the other is available to stop the vehicle. If your vehicle should lose the power assist for some reason, the brakes will still work. In these situations, even if the brake pedal moves down to the very end of its possible stroke or resists being depressed, keep depressing the brake pedal down harder and further than usual; stop driving as soon as possible and have the brake system repaired.

6

WARNING

- Do not turn off the engine while your vehicle is in motion. If you turn off the engine while driving, the power assistance for the braking system will stop working and your brakes will not work effectively.
- If the power assist is lost or if either brake hydraulic system stops working properly, take your vehicle to an authorised MITSUBISHI MOTORS dealer immediately.

Warning display

The brake warning lamp illuminates to indicate a fault in the braking system. A warning is also displayed on the multi-information display. Refer to “Brake warning lamp” and “Brake warning display” on page 5-34, 5-36.

When brakes are wet

Check the brake system while driving at a low speed immediately after starting, especially when the brakes are wet, to confirm they work normally.

A film of water can be formed on the brake discs and drums and prevent normal braking after driving in heavy rain or through large puddles, or after the vehicle is washed. If this occurs, dry the brakes out by driving slowly while lightly depressing the brake pedal.

When driving downhill

It is important to take advantage of the engine braking by shifting to a lower shift position while driving on steep downhill roads in order to prevent the brakes from overheating.

WARNING

- Do not leave any objects near the brake pedal or let a floor mat slide under it; doing so could prevent the full pedal stroke that would be necessary in an emergency. Make sure that the pedal can be operated freely at all times. Make sure the floor mat is securely held in place.

Brake pad

- Avoid hard braking situations. New brakes need to be broken-in by moderate use for the first 200 km.
- The disc brakes are provided with a warning device which emits a shrieking metallic sound while braking if the brake pads have reached their limit. If you hear this sound, have the brake pads replaced immediately.

WARNING

- Driving with worn brake pads will make it harder to stop, and can cause an accident.

Hill start assist

E00628001527

The hill start assist makes it easy to start off on a steep uphill slope by preventing the vehicle from moving backwards. It keeps the braking force for approximately 2 seconds when you move your foot from the brake pedal to the accelerator pedal.

⚠ CAUTION

- Do not overly rely on the hill start assist to prevent backwards movement of the vehicle. Under certain circumstances, even when hill start assist is activated, the vehicle may move backwards if the brake pedal is not sufficiently depressed, if the vehicle is heavily loaded, or if the road is very steep or slippery.
- The hill start assist is not designed to keep the vehicle stopped in place on uphill slopes for more than 2 seconds.
- When facing uphill, do not rely on using the hill start assist to maintain a stopped position as an alternative to depressing the brake pedal. Doing so could cause an accident.
- Do not turn the operation mode in ACC or OFF while the hill start assist is operating. The hill start assist could stop operating, which could result in an accident.

To operate

E00628101603

1. Stop the vehicle completely using the brake pedal.
2. Place the selector lever into the “D” (DRIVE) position.

📖 NOTE

- When reversing on an uphill slope, place the selector lever into the “R” (REVERSE) position.

3. Release the brake pedal and the hill start assist will maintain the braking force applied while stopped for approximately 2 seconds.
4. Depress the accelerator pedal and the hill start assist will gradually decrease the braking force as the vehicle starts moving.

📖 NOTE

- The hill start assist is activated when all of the following conditions are met.
 - The engine is running. (The hill start assist will not be activated while the engine is starting or immediately after the engine is started.)
 - The selector lever is in any position other than “P” (PARK) or “N” (NEUTRAL).
 - The vehicle is completely stationary, with the brake pedal depressed.
 - The parking brake is released.
- The hill start assist will not operate if the accelerator pedal is depressed before the brake pedal is released.
- The hill start assist also operates when reversing on an uphill slope.

Warning lamp/display

E00628201646

If an abnormal condition occurs in the system, the following warning lamp/display will be shown.

Warning lamp



Warning display



⚠ CAUTION

- If the warning is displayed, the hill start assist will not operate. Start off carefully.
- Park your vehicle in a safe place and stop the engine. Restart the engine and check whether the display/indicator goes out, in which case the hill start assist is again working normally. If they remain displayed or reappear frequently, it is not necessary to stop the vehicle immediately, but the vehicle should be inspected by an authorised MITSUBISHI MOTORS dealer.

Brake assist system

Brake assist system

E00627001979

The brake assist system is a device assisting drivers who cannot depress the brake pedal firmly such as in emergency stop situations and provides greater braking force.

6

If the brake pedal is depressed suddenly, the brakes will be applied with more force than usual.

CAUTION

- The brake assist system is not a device designed to exercise braking force greater than its capacity. Make sure to always keep a sufficient distance between your vehicle and a vehicle in front of you without relying too much on the brake assist system.

NOTE

- Once the brake assist system is operational, it maintains great braking force even if the brake pedal is lightly released. To stop its operation, completely remove your foot from the brake pedal.

NOTE

- When the brake assist system is in use while driving, you may feel as if the depressed brake pedal is soft, the pedal moves in small motions in conjunction with the operation noise, or the vehicle body and the steering wheel vibrate. This occurs when the brake assist system is operating normally and does not indicate faulty operation. Continue to depress the brake pedal.
- When the anti-lock brake system warning lamp or only active stability control warning lamp illuminate, the brake assist system is not functioning.

Emergency stop signal system

E00626001350

This is a device that reduces the possibility of rear end collisions by the rapid and automatic blinking of the hazard warning lamps to alert vehicles approaching from behind during sudden braking. When the emergency stop signal system operates, the hazard warning indicator lamp in the instrument cluster blinks rapidly at the same time.

CAUTION

- If the ABS warning or ASC warning is displayed, the emergency stop signal system may not operate. Refer to “ABS warning lamp/display” on page 6-30. Refer to “ASC warning lamp/display” on page 6-34.

NOTE

- [Activating condition for the emergency stop signal system]
It activates when all of the following conditions are met.
 - The vehicle speed is approximately 55 km/h or higher.
 - The brake pedal has been depressed, and the system judges that it was sudden braking from the vehicle deceleration and the operating condition of the anti-lock brake system (ABS).[Deactivating condition for the emergency stop signal system]
It deactivates when one of the following conditions is met.
 - The brake pedal is released.
 - The hazard warning flasher switch is pressed.
 - The system judges that it was not sudden braking from the vehicle deceleration and the operating condition of the anti-lock brake system (ABS).

Anti-lock brake system (ABS)

E00607102766

Environmental conditions can have an effect on braking. During sudden braking when there is snow, ice, oil, water etc. on the road surface, a skid may occur. In this situation, steering control and braking effectiveness is reduced and the stopping distance is increased. The vehicle may also go into an uncontrolled spin.

The ABS helps prevent the wheels from locking during braking, thus maintaining directional stability, ensuring controllability and providing optimum braking force.

Operating hints

- Always maintain the same distance from the vehicle in front of you as you would for a vehicle not equipped with ABS. Compared with vehicles not fitted with ABS, your vehicle may require a longer stopping distance in the following cases:
 - Driving on gravel or snow-covered roads.
 - Driving with tyre chains installed.
 - Driving on roads where the road surface is pitted or has other differences in surface height.

- Driving on bumpy roads or other poor driving surfaces.
- Operation of ABS is not restricted to situations where brakes are applied suddenly. This system may also operate to prevent wheel lock when you are driving over manholes, steel road-work plates, or the vehicle is driven over steps or level differences in the road, road markings, or other surfaces which are difficult for the wheels to grip.
- When the ABS is activated, you may feel the brake pedal pulsation and the vibrations of the vehicle body and steering wheel. You may also hear a characteristic noise. At this time, you may feel as if the pedal attempts to resist being depressed. This is a normal result of the ABS operation, and does not indicate a problem. **If this situation occurs, depress the brake pedal more firmly in order to operate the ABS. Do not pump the brake. This will result in reduced braking performance.**
- You will hear the operation sound of the motor coming from the engine compartment immediately following start off after starting the engine. If the brake pedal is depressed at that moment, a brake pedal pulsating is felt.

This pulsation is due to the self-diagnosis operation of the ABS and does not indicate a malfunction.

- The ABS becomes operative after the vehicle has accelerated to a speed in excess of approximately 10 km/h. It stops operating when the vehicle decelerates to a speed below approximately 5 km/h.

CAUTION

- Even the ABS cannot prevent the natural laws of physics from acting on the vehicle. It cannot for instance avoid accidents that may result from excessive speed on bends or following another vehicle too closely or aquaplaning. It should remain the driver's task to observe safety precautions to judge speeds and brake applications correctly in such conditions.
- Be sure to use tyres of the same type and size on 4 wheels. If tyre types or sizes are mixed, ABS may not function normally.
- Never install a limited slip differential, which is not MITSUBISHI MOTORS GENUINE parts, as the ABS may not function normally. We recommend you to consult an authorised MITSUBISHI MOTORS dealer.

6

Anti-lock brake system (ABS)

ABS warning lamp / display

E00607202682

Warning lamp



Warning display

6



If there is a malfunction in the system, the ABS warning lamp will come on and the warning display will appear on the information screen in the multi-information display. Under normal conditions, the ABS warning lamp only comes on when the ignition switch is turned to the “ON” position or the operation mode is put in ON and goes off a few seconds later.

CAUTION

- Any of the following warning lamp/display behaviour indicates that the ABS is not functioning and only the standard brake system is working. (The standard brake system is functioning normally.) If this happens, take your vehicle to an authorised MITSUBISHI MOTORS dealer.

CAUTION

- When the ignition switch is in the “ON” position or the operation mode is put in ON, the warning lamp does not come on or it remains on and does not go off
- The warning lamp comes on while driving
- The warning display appears while driving

If the warning lamp/display illuminate while driving

E00607302566

If only the ABS warning lamp/display illuminate

Avoid hard braking and high-speed driving. Stop the vehicle in a safe place. Restart the engine and check to see whether the lamp goes out after a few minutes driving; if it then remains off during driving, there is no problem. However, if the lamp does not go out, or if it lights up again when the vehicle is driven, we recommend you to have the vehicle checked as soon as possible.

If the ABS warning lamp/display and brake warning lamp/display illuminate at the same time

Warning lamp

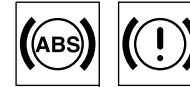

Warning display



The ABS and brake force distribution function may not work, so hard braking could make the vehicle unstable. Avoid hard braking and high-speed driving. Stop the vehicle in a safe place immediately and contact an authorised MITSUBISHI MOTORS dealer.

Electric power steering system (EPS)

NOTE

- The ABS warning lamp and brake warning lamp illuminate at the same time and the warning displays appear alternately on the information screen in the multi-information display.

After driving on icy roads

E00618801362

After driving on snow or icy roads, remove any snow and ice which may have been left around the wheels. When doing this, be careful not to damage the wheel speed sensors (A) or the cables located at each wheel.

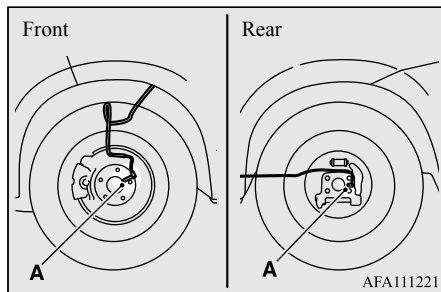

Electric power steering system (EPS)

E00629201496

The power steering system operates while the engine is running.

It helps reduce the effort needed to turn the steering wheel.

The power steering system has mechanical steering capability in case the power assist is lost. If the power assist is lost for some reason, you will still be able to steer your vehicle, but you will notice it takes much more effort to steer. If this happens, have your vehicle inspected at an authorised MITSUBISHI MOTORS dealer.

WARNING

- Do not stop the engine while the vehicle is moving. Stopping the engine would make the steering wheel extremely hard to turn, possibly resulting in an accident.

NOTE

- During repeated full-lock turning of the steering wheel (for example, while you are manoeuvring the vehicle into a parking space), a protection function may be activated to prevent overheating of the power steering system. This function will make the steering wheel gradually harder to turn. In this event, limit your turning of the steering wheel for a while. When the system has cooled down, the steering effort will return to normal.
- If you turn the steering wheel while the vehicle is stationary with the headlamps on, the headlamps may become dim. This behaviour is not abnormal. The headlamps will return to their original brightness after a short while.

6

Electric power steering system warning lamp/warning display

Warning lamp



Active stability control (ASC)

Warning display



6

If there is a malfunction in the system, the warning lamp will come on and the warning display will appear on the information screen in the multi-information display.

Under normal conditions, the warning lamp comes on when the ignition switch is turned to the “ON” position or the operation mode is put in ON, and goes off after the engine has started.

CAUTION

- If the warning lamp comes on and the warning display appears while the engine is running, have the vehicle inspected by an authorised MITSUBISHI MOTORS dealer as soon as possible.
It may become harder to turn the steering wheel.

Active stability control (ASC)

E00616701963

The active stability control (ASC) takes over all control of the anti-lock brake system, trac-

tion control function and stability control function to help maintain the vehicle’s control and traction. Please read this section in conjunction with the page on the anti-lock brake system, traction control function and stability control function.

Anti-lock brake system (ABS) → P.6-29

Traction control function → P.6-32

Stability control function → P.6-33

CAUTION

- Do not over-rely on the ASC. Even the ASC cannot prevent the natural laws of physics from acting on the vehicle.
This system, like any other system, has limits and cannot help you to maintain traction and control of the vehicle in all circumstances. Reckless driving can lead to accidents. It is the driver’s responsibility to drive carefully. This means into account the traffic, road and environmental conditions.
- Be sure to use the same specified type and size of tyre on all 4 wheels. Otherwise, the ASC may not work properly.
- Do not install any aftermarket limited slip differential (LSD) on your vehicle. The ASC may stop functioning properly.

NOTE

- An operation noise may be emitted from the engine compartment in the following situations. The sound is associated with checking the operations of the ASC. At this time, you may feel a shock from the brake pedal if you depress it. These do not indicate a malfunction.
 - When the ignition switch is set to the “ON” position or the operation mode is put in ON.
 - When the vehicle is driven for a while after the engine is turned on.
- When the ASC is activated, you may feel a vibration in the vehicle body or hear a whining sound from the engine compartment. This indicates that the system is operating normally. It does not indicate a malfunction.
- When the anti-lock brake system warning lamp is illuminated, the ASC is not active.

Traction control function

E00619001185

On slippery surfaces, the traction control function prevents the drive wheels from spinning excessive, thus helping the vehicle to start moving from a stopped condition. It also provides sufficient driving force and steering performance as the vehicle turns while pressing the acceleration pedal.

CAUTION

- When driving a vehicle on a snowy or icy road, be sure to install snow tyres and drive the vehicle at moderate speeds.

Stability control function

E00619101144

The stability control function is designed to help the driver maintain control of the vehicle on slippery roads or during rapid steering maneuvers. It works by controlling the engine output and the brake on each wheel.



NOTE

- The stability control function operates at speeds of approximately 15 km/h or higher.

ASC OFF switch

E00619201930

The ASC is automatically activated when the operation mode is put in ON. You can deactivate the system by pressing down the ASC OFF switch for 3 seconds or longer.

When the ASC is deactivated, the  indicator will turn on. To reactivate the ASC, momentarily press the ASC OFF switch; the  indicator is turned off.

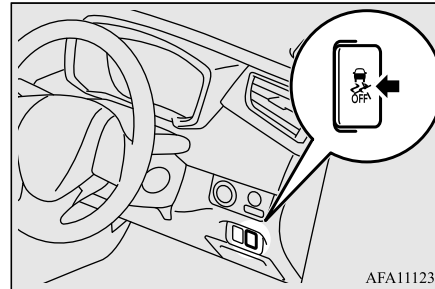

AFA111234

CAUTION



- For safety reasons, the ASC OFF switch should be operated when your vehicle is stopped.
- Be sure to keep the ASC on while driving in normal circumstances.

NOTE

- When moving out of mud, sand or fresh snow, pressing the accelerator pedal may not allow the engine speed to increase. In such situations, temporarily turning off the ASC with the ASC OFF switch will make it easier to move out your vehicle.
- Using the ASC OFF switch turns off both the stability control function and the traction control function.
- If you continue to press the ASC OFF switch after the ASC is turned off, the “mistaken operation protection function” will activate and the ASC will turn back on.

ASC operation indicator or ASC OFF indicator

E00619301872

-  - ASC operation indicator
The indicator will blink when the ASC is operating.
-  - ASC OFF indicator
This indicator will turn on when the ASC is turned off with the ASC OFF switch.

6

CAUTION

- When  indicator blinks, ASC is operating, which means that the road is slippery or that your vehicle’s wheels are beginning to slip. If this happens, drive slower with less accelerator input.

Cruise control*

6

CAUTION

- If the temperature in the braking system continues to increase due to continuous brake control on a slippery road surface, the  indicator will blink.

To prevent the brake system from overheating, the brake control of the traction control function will be temporarily suspended.

The engine control of the traction control function and normal brake operation will not be affected. Park your vehicle in a safe place. When the temperature in the braking system has come down, the  indicator will be turned off and the traction control function will start operating again.

NOTE

- The  indicator may turn on when you start the engine. This means that the battery voltage momentarily dropped when the engine was started. It does not indicate a malfunction, provided that the indicator goes out immediately.

ASC warning lamp/display

E00619402030

If an abnormal condition occurs in the system, the following warning lamp/warning display will turn on.

Warning lamp



- ASC operation indicator



- ASC OFF indicator

Warning display



CAUTION

- The system may be malfunctioning. Park your vehicle in a safe place and stop the engine. Restart the engine and check whether the display/indicator goes out. If they go out, there is no abnormal condition. If they do not go out or appear frequently, it is not necessary to stop the vehicle immediately, but we recommend you to have your vehicle inspected.

CAUTION

- When towing the vehicle with only the front wheels or only the rear wheels raised off the ground, do not place the ignition switch in the “ON” position or do not put the operation mode in ON. Placing the ignition switch in the “ON” position or putting the operation mode in ON could cause the ASC to operate, resulting in an accident.

Note that the correct towing method depends on the transmission type and the vehicle’s drive configuration.

For details, refer to “Towing” on page 8-12.

Cruise control*

E00609102685

Cruise control is an automatic speed control system that keeps a set speed. It can be activated at approximately 40 km/h or more.

CAUTION

- When you do not wish to drive at a set speed, turn off the cruise control for safety.
- Do not use cruise control when driving conditions will not allow you to stay at the same speed, such as in heavy traffic or on roads that are winding, icy, snow-covered, wet, slippery, on a steep downhill slope.

NOTE

- Cruise control may not be able to keep your speed on uphill or downhill.
- Your speed may decrease on a steep uphill. You may use the accelerator pedal if you want to stay at your set speed.
- Your speed may increase to more than the set speed on a steep downhill. You have to use the brake to control your speed. As a result, the set speed driving is deactivated.

Cruise control switches

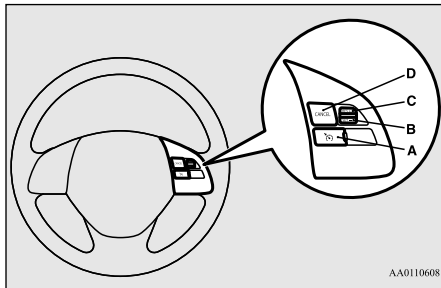

A- CRUISE CONTROL ON/OFF switch

Used to turn on and off the cruise control.

B- “SET -” switch

Used to reduce the set speed and to set the desired speed.

C- “RES +” switch

Used to increase the set speed and to return to the original set speed.

D- “CANCEL” switch

Used to deactivate the set speed driving.

NOTE

- When operating the cruise control switches, press the cruise control switches correctly. The set speed driving may be deactivated automatically if two or more switches of the cruise control are pressed at the same time.

To activate

1. With the operation mode in ON, press the CRUISE CONTROL ON/OFF switch (A) to turn on the cruise control. The indicator display appear on the information screen of the multi-information display.

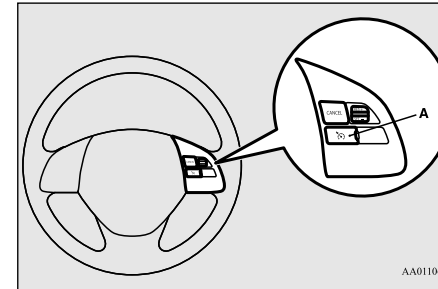

2. Accelerate or decelerate to your desired speed, then push down and release the “SET -” switch (B) when the indicator display appear on the information screen of the multi-information display. The vehicle will then maintain the desired speed. The “SET” indicator appears on the information screen of the multi-information display.

Cruise control*

6

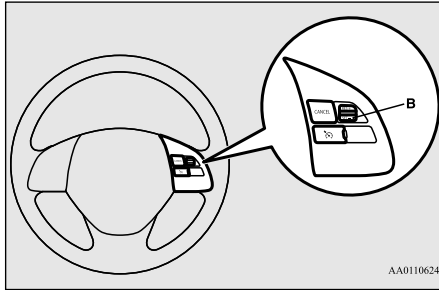

NOTE

- When you release the “SET -” switch (B), the vehicle speed will be set.

To increase the set speed

E00609401955

There are two ways to increase the set speed.

RES + switch

Push up and hold the “RES +” switch (C) while driving at the set speed, and your speed will then gradually increase.

When you reach your desired speed, release the switch. Your new cruising speed is now set.

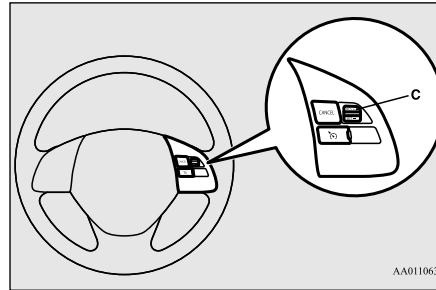

To increase your speed in small amounts, push up the “RES +” switch (C) for less than approximately 1 second and release it. Each time you push up the “RES +” switch (C), your vehicle will go approximately 1.6 km/h faster.

Accelerator pedal

While driving at the set speed, use the accelerator pedal to reach your desired speed and then push down the “SET -” switch (B) and release the switch momentarily to set a new desired cruising speed.

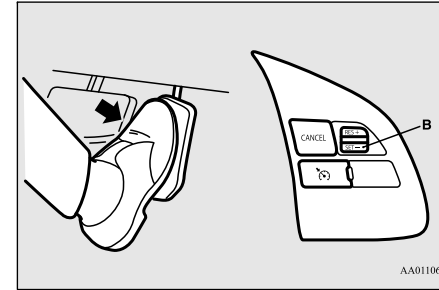

To decrease the set speed

E00609501884

There are two ways to decrease the set speed.

SET - switch

Push down and hold the “SET -” switch (B) while driving at the set speed, and your speed will slow down gradually.

When you reach your desired speed, release the switch. Your new cruising speed is now set.

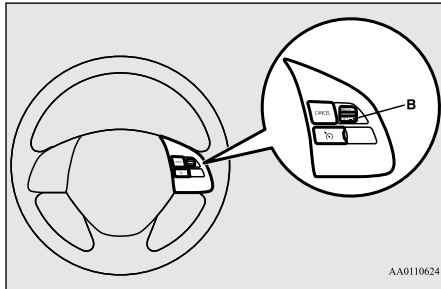

AA0110624

To slow down your speed in small amounts, push down the “SET -” switch (B) for less than approximately 1 second and release it. Each time you push down the “SET -” switch (B), your vehicle will slow down by approximately 1.6 km/h.

Brake pedal

While driving at the set speed, use the brake pedal, which disengages the cruise control, then push down the “SET -” switch (B) and release the switch momentarily to set a new desired cruising speed.

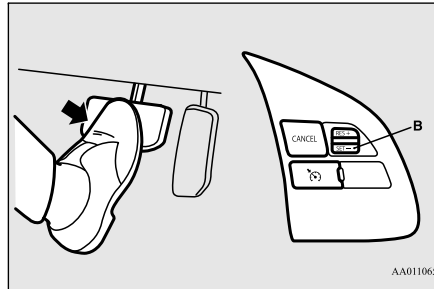

AA0110653

To temporarily increase or decrease the speed

E00609601436

To temporarily increase the speed

Depress the accelerator pedal as you would normally. When you release the pedal, you will return to your set speed.

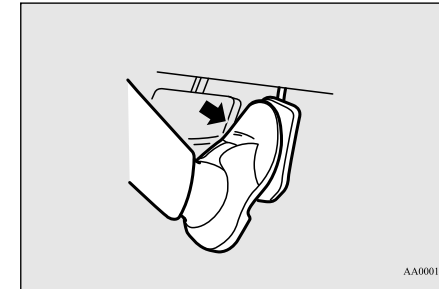

AA0001395

NOTE

- In some driving conditions, the set speed driving may be deactivated. If this happens, refer to “To activate” on page 6-35 and repeat the speed setting procedure.

To temporarily decrease the speed

Depress the brake pedal to decrease the speed. To return to the previously set speed, push up the “RES +” switch (C). Refer to “To resume the set speed” on page 6-38.

Cruise control*

6

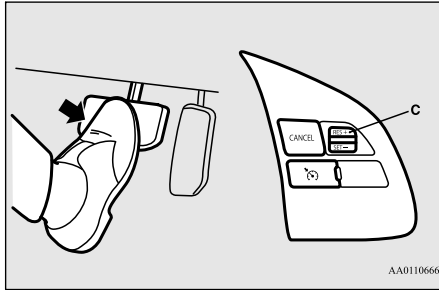

To deactivate

E00609703125

The set speed driving can be deactivated as follows:

- Press the CRUISE CONTROL ON/OFF switch (A). (Cruise control will be turned off.)
- Press the “CANCEL” switch (D).
- Depress the brake pedal.

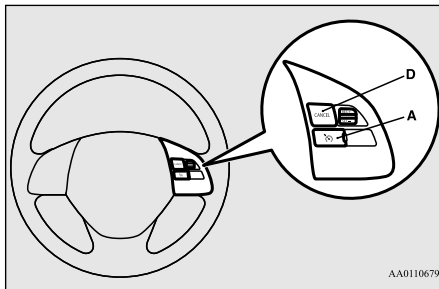

6-38 Starting and driving

The set speed driving is deactivated automatically in any of the following ways.

- When your speed slows to approximately 15 km/h or more below the set speed because of a hill, etc.
- When your speed slows to approximately 40 km/h or less.
- When the active stability control (ASC) starts operating.
Refer to “Active stability control (ASC)” on page 6-32.

WARNING

- **Although the set speed driving will be deactivated when shifting to the “N” (NEUTRAL) position, never move the selector lever to the “N” (NEUTRAL) position while driving. You would have no engine braking and could cause a serious accident.**

Also, the set speed driving may be deactivated as follow:

- When the engine speed rises and approaches the tachometer’s red zone (the red-coloured part of the tachometer dial).

CAUTION

- When the set speed driving is deactivated automatically in any situation other than those listed above, there may be a system malfunction.
Press the CRUISE CONTROL ON/OFF switch to turn off the cruise control and have your vehicle inspected by an authorised MITSUBISHI MOTORS dealer.

To resume the set speed

E00609802305

If the set speed driving is deactivated by the condition described in “To deactivate” on page 6-38, you can resume the previously set speed by push up the “RES +” switch (C) while driving at a speed of approximately 40 km/h or higher. The “SET” indicator appears on the information screen of the multi-information display.

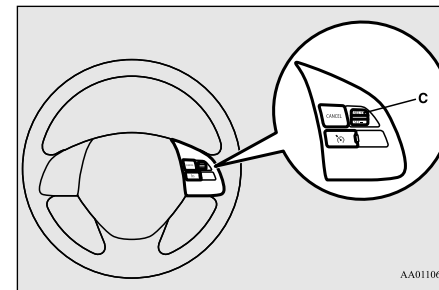



Under either of the following conditions, however, using the switch does not allow you to resume the previously set speed. In these situations, repeat the speed setting procedure:

- The CRUISE CONTROL ON/OFF switch is pressed.
- The operation mode is put in OFF.
- Indicator display goes off.

Rear-view camera*

E00618402961

The rear-view camera is a system that shows the view behind the vehicle on a screen of the Display audio.

CAUTION

- The rear-view camera is an assistance system that enables the driver to check for obstacles behind the vehicle. Its range of view is limited, so you should not overly depend on it. Please drive just as carefully as you would if the vehicle did not have the rear-view camera.
- Be sure to visually confirm safety around the vehicle with your own eyes. Do not depend entirely on the rear-view camera.

Range of view of rear-view camera

The range of view of the rear-view camera is limited to the area shown in the illustrations. It cannot show the both sides and the lower part of the rear bumper, etc.

When reversing, be sure to visually confirm safety around the vehicle.

Location of rear-view camera

The rear-view camera (A) is integrated into the part near the tailgate handle.

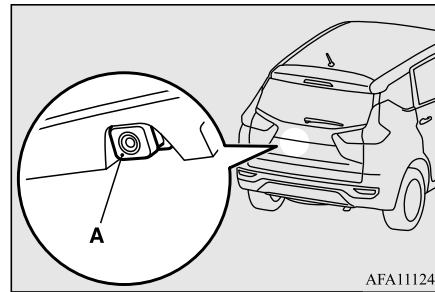

Range of view of rear-view camera

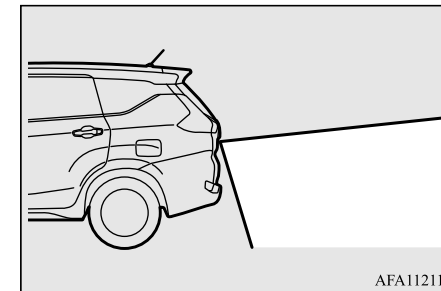
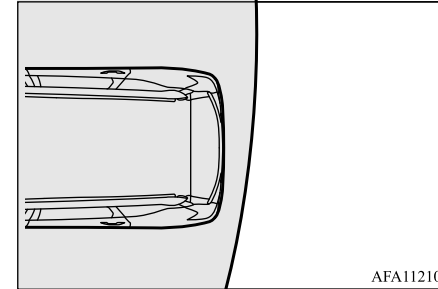

How to use the rear-view camera

When you place the selector lever in the “R” (REVERSE) position with the operation mode in ON, the view behind the vehicle will

Rear-view camera*

6

Rear-view camera*

automatically appear on the screen of the Display audio. When you move the selector lever to any other position, the screen will return to its original indication.

CAUTION

- The rear-view camera has a special lens that can make objects shown on the screen appear to be closer or further away than they actually are.

6

NOTE

- Because the rear-view camera has a special lens, the lines on the ground between parking spaces may not look parallel on the screen.
- In the following situations, the screen indication may be difficult to see. There is no abnormality.
 - Low light (nighttime)
 - When the light of the sun or the light from a vehicle's headlamps shines directly into the lens
- If the camera is hot and is then cooled by rain or a car wash, the lens can mist up. This phenomenon does not indicate a malfunction.
- It is not possible to fully see obstacles when the lens is dirty. If the lens becomes contaminated by water droplets, snow, mud, or oil, wipe off the contamination, taking care not to scratch the lens.

NOTE

- Please observe the following cautions. Ignoring them could lead to a camera malfunction.
 - Do not subject the camera to physical shock.
 - Do not apply wax to the camera.
 - Do not splash the camera with boiling water.
 - Do not disassemble the camera.

Reference lines on the screen

Three reference lines for distance and the top of the rear bumper (A) are shown on the screen.

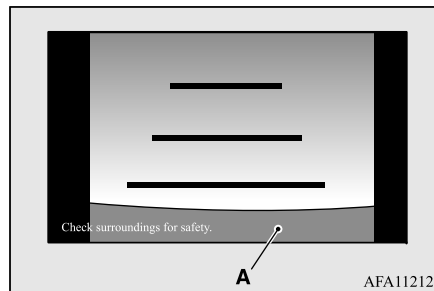

NOTE

- When the vehicle is tilting because of the number of people in the vehicle, the weight and positioning of luggage, and/or the condition of the road surface, the lines in the view from the rear-view camera may not be accurately positioned relative to the actual road. The reference lines for distance and vehicle width are based on a level, flat road surface. In the following cases, objects shown on the screen will appear to be farther off than they actually are.
 - When the rear of the vehicle is weighed down with the weight of passengers and luggage in the vehicle.

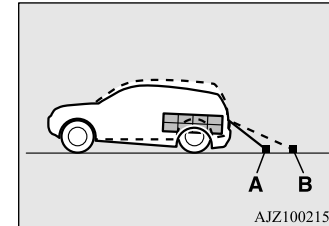

- A: Actual objects
- B: Objects shown on the screen

NOTE

- When there is an upward slope at the back.

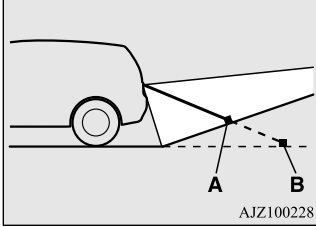

AJZ100228

A: Actual objects
B: Objects shown on the screen

NOTE

- The reference lines for distance and vehicle width are intended to indicate the distance to a flat object such as a level, flat road surface. This may make the distance to a projecting object shown on the screen differ from the actual distance to the projecting object. Do not use them as a guide to distances to solid objects.

Example: On the screen the point B appears the nearest, then the point C and A in order of distance. The point A and B actually are the same distances from the vehicle, and the point C is farther off than the point A and B.

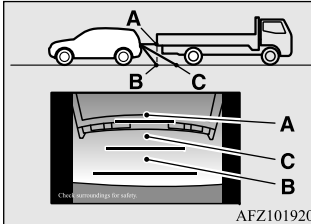

AFZ101920

Cargo loads

E00609902902

Cargo loads precautions

CAUTION

- Do not load cargo or luggage higher than the top of the seatback. Be sure that your cargo or luggage cannot move once your vehicle is moving. Having the rear view blocked, and your cargo being thrown inside the cabin if you suddenly have to brake can cause a serious accident or injury.
- Load heavy cargo or luggage in the front of the vehicle. If the load in the back of the vehicle is too heavy, steering may become unstable.

6



For pleasant driving

Important air conditioning operating tips	7-2	Bottle holder	7-39
Ventilators	7-2	Convenient hook	7-40
Manual air conditioning	7-6	Assist grips	7-40
Rear air conditioning	7-8	Coat hook	7-40
Air purifier	7-9		
AM/FM radio/CD player with AUX*	7-9		
Handling of Discs	7-10		
Audio Files (MP3/WMA/AAC)	7-12		
Important Points on Safety for the Customer	7-15		
Operation Keys	7-16		
Listen to Radio	7-19		
Listen to CDs	7-20		
Listen to MP3s/WMA/AACs	7-21		
Listen to an iPod*	7-22		
Listen to Audio Files on a USB Device*	7-24		
Use AUX*	7-26		
Display Indicator	7-26		
Audio Quality and Volume Balance Adjustment	7-27		
Time Setting	7-28		
Troubleshooting	7-29		
Antenna*	7-30		
Link System*	7-31		
USB input terminal*	7-31		
Sun visors	7-33		
Accessory socket	7-34		
Room lamps	7-34		
Storage spaces	7-36		
Drink holder	7-39		

Important air conditioning operating tips

Important air conditioning operating tips

E00708302522

CAUTION

- The engine speed may increase when the air conditioning is operating. With an increased engine speed, an A/T vehicle will creep to a greater degree than with a lower engine speed. Fully depress the brake pedal to prevent the vehicle from creeping.

7

- Park the vehicle in the shade. Parking in the hot sun will make the vehicle inside extremely hot, and it will require more time to cool the interior. If it is necessary to park in the sun, open the windows for the first few minutes of air conditioning operation to expel the hot air.
- Close the windows when the air conditioning is in use. The entry of outside air through open windows will reduce the cooling efficiency.
- Too much cooling is not good for the health. The inside air temperature should only be 5 to 6 °C below the outside air temperature.

- When operating the system, make sure the air intake, which is located in front of the windscreen, is free of obstructions such as leaves and snow. Leaves collected in the air-intake plenum may reduce air flow and plug the plenum water drains.

Air conditioning system refrigerant and lubricant recommendations

If the air conditioning seems less effective than usual, the cause might be a refrigerant leak. We recommend you to have the system inspected.

The air conditioning system in your vehicle must be charged with the refrigerant HFC-134a and the lubricant ND-OIL8.

Use of any other refrigerant or lubricant will cause severe damage which will result in the need to replace your vehicle's entire air conditioning system. The release of refrigerant into the atmosphere should be prevented. It is recommended that the refrigerant be recovered and recycled for further use.

During a long period of disuse

The air conditioning should be operated for at least five minutes each week, even in cold

weather. This is to prevent poor lubrication of the compressor internal parts and to maintain the air conditioning in the best operating condition.

Ventilators

E00700102247

Front ventilators

E00774900064

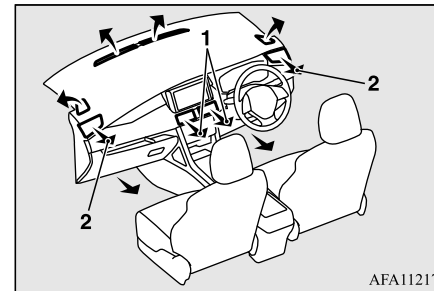

AFA112172

- 1- Centre ventilators
- 2- Side ventilators

Rear ventilators

E00775000088

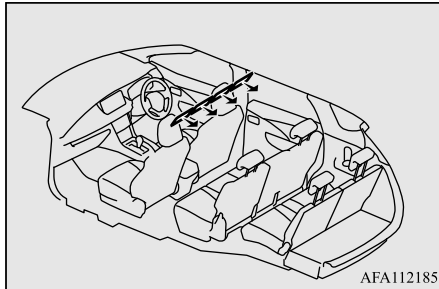

AFA112185

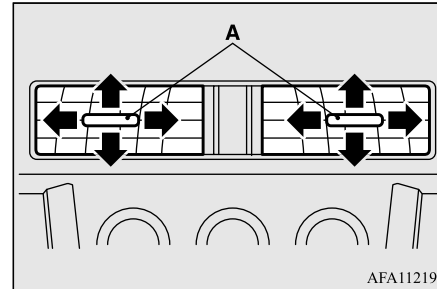

AFA112198

Front side ventilators

Move the knob (A) to adjust the air flow direction.

To close the vent, move the knob (A) to the outside as far as possible.

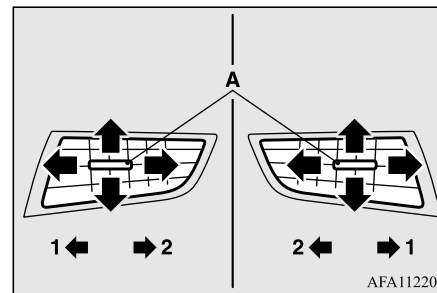

AFA112202

- 1- Close
- 2- Open

Adjusting the air flow direction

E00700202352

Front centre ventilators

Move the knob (A) to adjust the air flow direction.

Rear ventilators

Move the knob (A) to adjust the air flow direction.

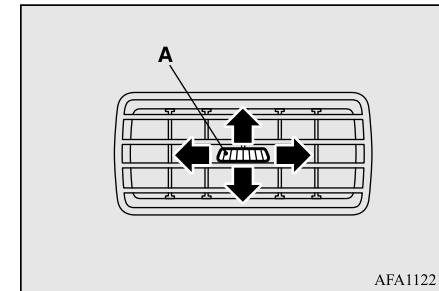

AFA112215

7

NOTE

- The cool air from the ventilators may appear as a mist. This is due to moist air being suddenly cooled by the air conditioning. This will clear after a few moments.
- Be careful not to spill beverages, etc., into the ventilators. Doing so might cause the air conditioning not to function normally.

Ventilators

Changing the position of air flowing from the front ventilators

E00700302757

To change the position and amount of air flowing from the front ventilators, turn the mode selection dial.

7

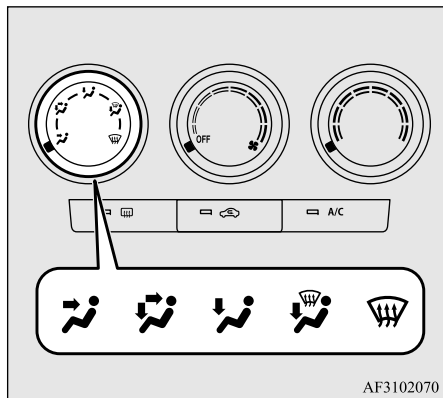

7-4 For pleasant driving



The mode selection and air flowing from the front ventilators

These symbols are used in the next several illustrations to demonstrate the quantity of air coming from the front ventilators.



→: Small amount of air from the ventilators

↔: Medium amount of air from the ventilators

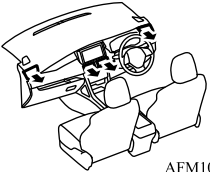
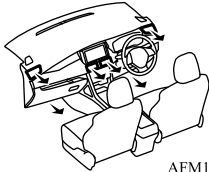
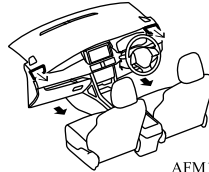

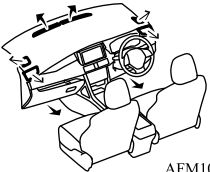
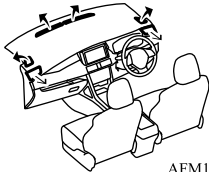

➔: Large amount of air from the ventilators

 Face position	 Foot/Face position	 Foot position
 <p style="text-align: center;">AFM102391</p>	 <p style="text-align: center;">AFM102375</p>	 <p style="text-align: center;">AFM102388</p>

7

 Foot/Demister position	 Demister position
 <p style="text-align: center;">AFM102405</p>	 <p style="text-align: center;">AFM102418</p>

NOTE

- With the mode selection dial between the “” and “” positions, air flows mainly to the upper part of the passenger compartment. With the mode selection dial between the “” and “” positions, air flows mainly to the leg area.

Manual air conditioning

Manual air conditioning

E00731101161

The air conditioning can only be used while the engine is running.

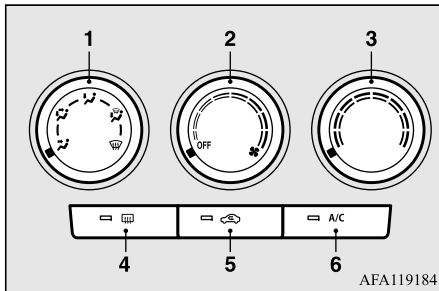

- 1- Mode selection dial → P.7-4
- 2- Blower speed selection dial → P.7-6
- 3- Temperature control dial → P.7-7
- 4- Rear window demister switch → P.5-44
- 5- Air selection switch → P.7-7
- 6- Air conditioning switch → P.7-7

● Usage

- Changing the position of air flowing from the ventilators → P.7-4
- Demisting of the windscreen and door windows → P.7-6
- Adjusting the blower speed → P.7-6
- To stop the fan → P.7-7

7-6 For pleasant driving

- Adjusting the temperature control → P.7-7
- Cooling → P.7-8
- Heating → P.7-8
- Switching the air conditioning system ON/OFF → P.7-7
- Switching outside air and recirculated air → P.7-7
- Driving in polluted outside air conditions → P.7-8

Demisting of the windscreen and door windows

E00776400050

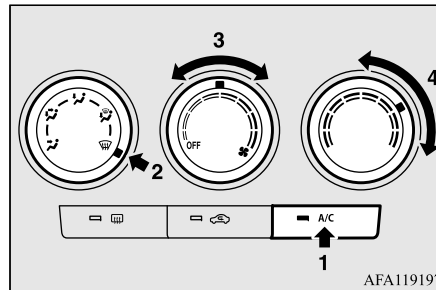

1. Press the air conditioning switch to turn it on.
2. Set the mode selection dial to the “windshield” position.

3. Select your desired blower speed by turning the blower speed selection dial clockwise or anticlockwise.
4. Set the temperature rather high by using the temperature control dial.

⚠ CAUTION

- For safety, make sure you have a clear view through all the windows.
- Do not set the temperature to the max. cool position. Cool air will blow against the window glasses and prevent demisting.

📖 NOTE

- When demisting quick, set the blower to the maximum speed and the temperature to the highest position.
- To demist the door windows effectively, direct the air flowing of the side ventilators towards the door windows.
- When the mode selection dial is set to the “windshield” position, the air selection will automatically be set to outside air.

Adjusting the blower speed

E00771500069

Select the blower speed by turning the blower speed selection dial clockwise or anticlockwise.

The blower speed will gradually increase as the dial is turned clockwise.

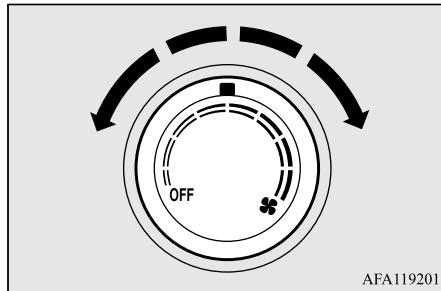

To stop the fan

E0077210062

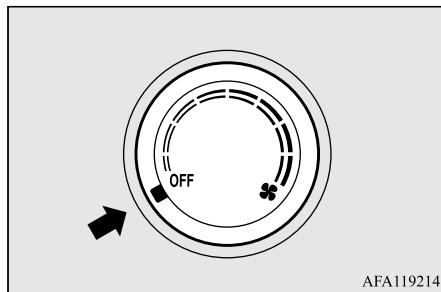

Turn the blower speed selection dial to the "OFF" position.

Adjusting the temperature control

E0077160060

The temperature control dial is used to select the desired air temperature. Turn the temperature control dial clockwise to make the air warmer. Turn it anticlockwise to make the air cooler.

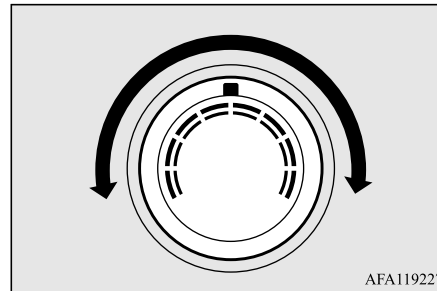

Switching the air conditioning system ON/OFF

E0077590045

Press the switch to turn the air conditioning on, the indicator lamp (A) will come on. Press the switch again to switch it off.

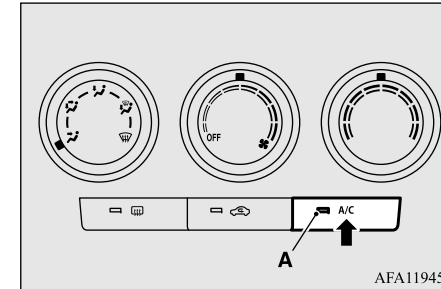

Switching outside air and recirculated air

E0077190063

To change the air selection, simply press the air selection switch.

- Outside air: Indicator lamp (A) is OFF
Outside air is introduced into the passenger compartment.
- Recirculated air: Indicator lamp (A) is ON
Air is recirculated inside the passenger compartment.

Rear air conditioning

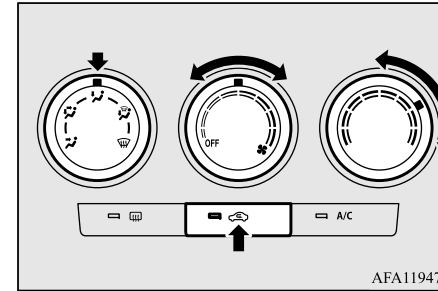
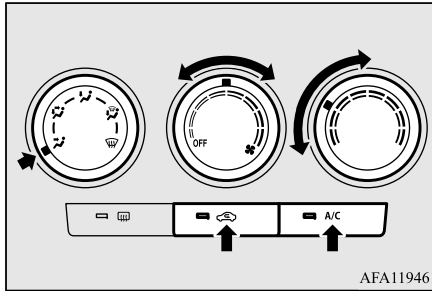
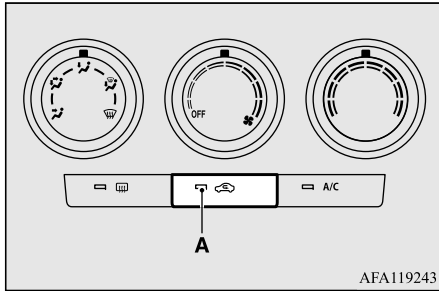

7

CAUTION

- Normally, use the outside position to keep the windscreen and side windows clear and quickly remove fog or frost from the windscreen.
If high cooling performance is desired, or if the outside air is dusty or otherwise contaminated, use the recirculation position. Switch to the outside position periodically to increase ventilation so that the windows do not become fogged up.
- Use of the recirculation position for an extended time may cause the windows to fog up.

Cooling

E0077180062

Select dials and switches as shown in the illustration according to your purpose.

CAUTION

- If high cooling performance is desired, set air selection switch to the recirculation position and the temperature control dial all the way to the left.
Switch to the outside position periodically to increase ventilation so that the windows do not become fogged up.

Heating

E0077570043

Select dials and switch as shown in the illustration according to your purpose.

Driving in polluted outside air conditions

E00775200064

If the outside air is dusty or otherwise contaminated when driving through a tunnel or in a traffic jam, press the air selection switch to set the air selection to recirculated air. Refer to “Switching outside air and recirculated air” on page 7-7.

Rear air conditioning

E007701287

The rear air conditioning can be used while the manual air conditioning is turned on. Refer to “Cooling” on page 7-8.

1. Turn the temperature control dial to turn on the manual air conditioning.

2. Select your desired blower speed by turning the blower speed selection dial of the rear air conditioning clockwise or anti-clockwise.

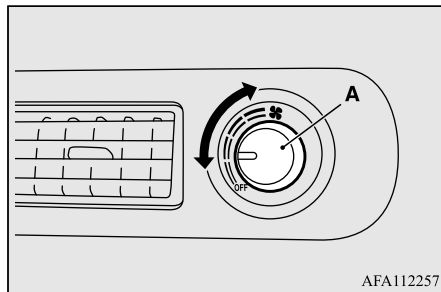

A- Blower speed selection dial

When the engine is stopped or the manual air conditioning is not turned on, the rear air conditioning fan will operate without cooling.

Air purifier

E00708401861

An air filter has been incorporated into this air conditioning so that dirt and dust are cleaned from the air.

Replace the air filter periodically as its ability to clean the air will be reduced as it collects pollen and dirt. For the maintenance interval, refer to the "SERVICE BOOKLET".

NOTE

- Operation in certain conditions such as driving on a dusty road and frequent use of the air conditioning can lead to reduction of service life of the filter. When you feel that the airflow is lower than normal or when the windscreen or windows start to fog up easily, replace the air filter. We recommend you to have it checked.

AM/FM radio/CD player with AUX*

E00708503866

The audio system can only be used when the ignition switch or the operation mode is in ON or ACC.

NOTE

- For vehicles equipped with the Keyless operation system, if the operation mode is left in ACC, the accessory power will automatically turn off after a certain period of time and you will no longer be able to use the audio system. The accessory power comes on again if the engine switch is operated with it in the "ACC" position. Refer to "ACC power auto-cutout function" on page 6-12.

NOTE

- If a cellular phone is used inside the vehicle, it may create noise from the audio equipment. This does not mean that anything is wrong with your audio equipment. In such a case, use the cellular phone at a place as far away as possible from the audio equipment.
- If foreign objects or water get into the audio equipment, or if smoke or a strange odour comes from it, immediately turn off the audio system. We recommend you to have it checked. Never try to repair it by yourself. Avoid continuous usage without inspection by a qualified person.

7

Important Points on Usage

E00735501118

iPod/iPhone Playback Function*

- This product supports audio playback from iPod/iPhone devices, however differing versions mean that playback cannot be guaranteed.
- Please be aware that depending on the iPod/iPhone model or version, operation may differ.

How to Clean

E00735701149

- If the product becomes dirty, wipe with a soft cloth.

Handling of Discs

- If very dirty, use a soft cloth dipped in neutral detergent diluted in water, and then wrung out. Do not use benzene, thinners, or other chemical wipes. This may harm the surface.

Trademarks

E00735801456

- Product names and other proper names are the trademarks or registered trademarks of their respective owners.
- Furthermore, even if there is no specific denotation of trademarks or registered trademarks, these are to be observed in their entirety.



“Made for iPod”, “Made for iPhone” mean that an electronic accessory has been designed to connect specifically to iPod or iPhone, respectively, and has been certified by the developer to meet Apple performance standards.

iPhone, iPod, iPod classic, iPod nano, and iPod touch are trademarks of Apple Inc., registered in the U.S. and other countries. Apple is not responsible for the operation of this device or its compliance with safety and regulatory standards.

NOTE

- iPod and iTunes licensing allows individual users to privately reproduce and play non-copyrighted material as well as material that may be legally copied and reproduced. Infringement of copyright is prohibited.

Supported models

- iPhone5S
- iPhone5c
- iPhone5
- iPhone4S
- iPhone4
- iPhone3GS
- iPhone3G
- iPhone
- iPod Nano (3rd Generation ~ 7th Generation)
- iPod Touch (1st Generation ~ 5th Generation)
- iPod Classic

Handling of Discs

E00735901255

This explains care that should be taken in the handling of discs.

Important Points on Handling

- Fingerprints or other marks on the read surface of the disc may result in its content being more difficult to read. When holding the disc, grip both edges, or one edge and the centre hole, in order that the read surface is not touched.
- Do not affix paper or stickers, or otherwise damage the disc.
- Do not forcefully insert a disc if another is already within the device. This can result in damage to discs, or malfunction.

Cleaning

- Periodically clean the read surface of the disc. When cleaning, do not wipe in a circular motion. Instead, wipe gently outwards from the centre of the disc to the outer edge.
- New discs may have burring around the outer edge or in the hole in the centre. Ensure you check for these. If there are burrs, these may lead to faulty operation, therefore ensure these are removed.

Important Points on Storage

- When not using discs, ensure these are kept in cases, and stored out of direct sunlight.

- If discs are not going to be used for a long period of time, remove these from the product.

Disc Playback Environment

In cold environments such as in mid-winter when the interior of the vehicle is cold, turning the heater on and immediately trying to use the product may cause condensation (water droplets) to form on the disc and internal optical components, and this may prevent the product from operating correctly. In these conditions, remove the disc, and wait a short time before use.





Copyright

Actions such as unauthorised reproduction, broadcast, public performance, or rental of discs that comprise other than personal use are prohibited by law.

Types of Disc That Can Be Played

E00736001224

The following marks are printed on the disc label, package, or jacket.

Type	Size	Maximum playing time	Comments
CD-DA 	12 cm	74 minutes	—
CD-TEXT 	12 cm	74 minutes	—
CD-R/RW  	12 cm	—	•Disc containing MP3, WMA, AAC files

Discs That May Not Be Played

- Playback of discs other than those described in “Types of Disc That Can Be Played” is not guaranteed.
- 8 cm discs may not be used.
- Do not insert irregularly-shaped discs (for example, heart-shaped), as these may result in malfunction. Additionally, discs that have transparent portions may not be played.

- Discs that have not been finalized cannot be played.
- Even if recorded using the correct format on a recorder or computer, application software settings and environments; disc peculiarities, damage, or marking; or dirt or condensation on the lens inside the product may render the disc unplayable.
- Depending on the disc, some functions may not be used, or the disc may not be played.
- Do not use discs with cracks or warps.
- If the disc has stickers affixed, remains from removed stickers, or affixed adhesive, then do not use the disc.
- Discs that have decorative labels or stickers may not be used.

7

Nonstandard CDs

This product will play audio CDs, however please be aware of the following points regarding CD standards.

- Ensure that you use discs with  on the label surface.
- Playback of other than standard CDs is not guaranteed. Even if the audio can be played, the audio quality cannot be guaranteed.
- When playing other than standard CDs, the following may occur.

Audio Files (MP3/WMA/AAC)

- There may be noise during playback.
- There may be jumping in the audio.
- The disc may not be recognized.
- The first track may not be played.
- It may take longer than usual before start of playback of tracks.
- Playback may start from within the track.
- Some parts may not be played.
- Tracks may freeze during playback.
- Tracks may be displayed erroneously.

7

Audio Files (MP3/WMA/AAC)

E00736101238

This product can play MP3/WMA/AAC format audio files recorded on CD-ROM, CD-R/RW, and USB devices.

There are limitations on the files and media that can be used, therefore read the following prior to recording MP3/WMA/AAC format audio files on discs or USB devices.

Additionally, ensure you read the owner's manuals for your CD-R/RW drive and the writing software, and ensure these are used correctly.

If the MP3/WMA/AAC format audio files includes title information or other data, then this can be displayed.

CAUTION

- Actions such as copying audio CDs or files and either distributing these to others for free or for charge, or uploading files via the Internet or other means to servers is an infringement of the law.
- Do not append the file extensions “.mp3”, “.wma”, or “.m4a”, to other than MP3/WMA/AAC format files. Playing discs with these types of files recorded upon them may cause the files to be incorrectly identified for playback, which may lead to loud noise, resulting in speaker damage or accident.

NOTE

- Depending on the condition of the disc recorder or recording software used, correct playback may not be possible. In these cases, refer to the owner's manual for your product or software.
- Depending on your computer's operating system, version, software, or settings, files may not have a file extension appended. In these cases, append the file extensions “.mp3”, “.wma”, or “.m4a” when copying the files.
- Files larger than 2GB in size cannot be played back.

Folder Structure

E00736301139

Up to 8 folder levels can be recognized.

You can create a folder structure as in Genre - Artist - Album - Track (MP3/WMA/AAC format audio files) for management of tracks.

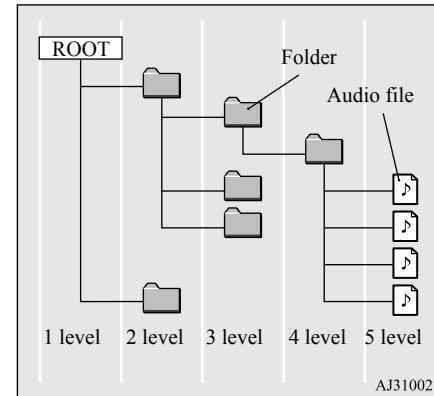

Audio Files (MP3/WMA/AAC)

Name	Specification	Explanation	
Format specifications	ISO9660	Level 1	Maximum 8 character file name, and 3 character file extension. (single-byte alphanumeric capital letters, numerals, “_” may be used)
	ISO9660 extension	Joliet	Files names up to a maximum 64 characters can be used.
Multisession	Not supported (only first session supported)		
Maximum number of levels	8 levels (if the root is the 1st level)		
Maximum folder number (including root)	CD	255 folders	
	USB	100 folders	

Name	Specification	Explanation
Maximum file number (total number on media)	CD	509 files
	USB	10,000 files (Up to 100 files can be stored in one folder.)
File name and folder name restrictions	Maximum 64 bytes (for Unicode, 32 characters), files/ folders with file/ folder names longer than this will not be displayed or played.	
USB supported formats	The recommended file system is FAT32. 1 partition only	

NOTE

- The order in which folders and audio files are displayed on this product may be different to how they are displayed on a computer.

What Is MP3?

E00736401084

MP3 is an abbreviation of “MPEG-1 Audio Layer 3”. MPEG is an abbreviation of “Motion Picture Experts Group”, and this is a

video compression standard used in video CDs, etc.

MP3 is one of the audio compression methods contained in the MPEG audio standard, and reduces the quality of sounds that are beyond the auditory resolution of the human ear and that are hidden by louder sounds, thus creating high-quality data with a lower data size.

Because this can compress CD audio to approximately 1/10 its original data size without perceptible loss, approximately 10 CDs can be written to a single CD-R/RW disc.

7

CAUTION

- MP3 files different to the standards at right may not be played correctly, or file/folder names may not be displayed correctly.

Standards for MP3 Files That Can Be Played

Specifications for MP3 files that can be played are as below.

Item	Details
Specification	MPEG-1 AUDIO LAYER3
	MPEG-2 AUDIO LAYER3

Audio Files (MP3/WMA/AAC)

7

Item	Details
Sampling frequency [kHz]	MPEG-1: 32/44.1/48
	MPEG-2: 16/22.05/24
Bit rate [kbps]	MPEG-1: 32 to 320
	MPEG-2: 8 to 180
VBR (variable bit rate)	Support
Channel mode	Stereo/ Joint stereo/ Dual channel/ Monaural
File extension	mp3
Supported tag information	ID3 tag Ver. 1.0, Ver. 1.1, Ver. 2.2, Ver. 2.3, Ver. 2.4 (ISO-8859-1, UTF-16 (Unicode)), Titles, Artist name, Album name
Maximum number of characters that can be indicated on the display	64 characters

What Is WMA?

E00736601073

WMA is an abbreviation of Windows Media Audio, and this is an audio compression format from Microsoft. This is a compression

7-14 For pleasant driving

format that has a higher compression ratio than MP3.

NOTE

- Microsoft, Windows Media, and Windows are registered trademarks of Microsoft Corporation (USA) and in other countries.

CAUTION

- WMA supports digital rights management (DRM). This product cannot play WMA files protected using this system.
- WMA files different to the standards at right may not be played correctly, or file/folder names may not be displayed correctly.
- “Pro”, “Lossless”, and “Voice” are not supported.

Standards for WMA Files That Can Be Played

Specifications for WMA files that can be played are as below.

Item	Details
Specification	Windows Media Audio Version 7.0/8.0/9.0
Sampling frequency [kHz]	32/44.1/48

Item	Details
Bit rate [kbps]	32 to 192
VBR (variable bit rate)	Support
Channel mode	Stereo/Monaural
File extension	wma
Supported tag information	WMA tags Title name, Artist name, Album name
Maximum number of characters that can be indicated on the display	64 characters

What Is AAC?

E00736801088

AAC is an abbreviation of Advanced Audio Coding, and this is an audio compression standard used in “MPEG-2” and “MPEG-4”. This features 1.4x the compression of MP3, with comparable audio quality.

CAUTION

- AAC supports digital rights management (DRM). This product cannot play AAC files protected using this system.

⚠ CAUTION

- AAC files different to the standards at right may not be played correctly, or file/folder names may not be displayed correctly.

Standards for AAC Files That Can Be Played

Specifications for AAC files that can be played are as below.

Item		Details
Specification		Advanced Audio Coding MPEG4/AAC-LC MPEG2/AAC-LC
Sampling frequency [kHz]	MPEG4	8/11.025/12/16/22.05/24/32/44.1/48
	MPEG2	8/11.025/12/16/22.05/24/32/44.1/48
Bit rate [kbps]	MPEG4	16 to 320
	MPEG2	16 to 320
VBR (variable bit rate)		Support
Channel mode		Stereo/Monaural
File extension		m4a

Item	Details
Supported tag information	AAC tags or ID3 tags Title, Artist name, Album name
Maximum number of characters that can be indicated on the display	64 characters

Important Points on Safety for the Customer

E00737001276

This product features a number of pictorial indications as well as points concerning handling so that you can use the product correctly and in a safe manner, as well as prevent injury or damage to yourself, other users, or property.

⚠ WARNING

- The driver should not pay close attention to the display while driving. This may prevent the driver looking where they are going, and cause an accident.

⚠ WARNING

- The driver should not perform complicated operations while driving. Performing complicated operations while driving may prevent the driver looking where they are going, and cause an accident. Therefore stop the vehicle in a safe location before performing such operations.
- Do not use during malfunctions, such as when no sound is audible. This may lead to accident, fire, or electric shock.
- Ensure water or other foreign objects do not enter the product. This may lead to smoking, fire, electric shock, or malfunction.
- Do not insert foreign objects into the disc slot. This may lead to fire, electric shock, or malfunction.
- In the event of abnormalities occurring when foreign objects or water enter the product, resulting in smoke or a strange smell, immediately stop using the product, and consult an authorised MITSUBISHI MOTORS dealer. Continuing to use the product may result in accident, fire, or electric shock.
- Do not disassemble or modify the product. This may lead to malfunction, fire, or electric shock.

Operation Keys

WARNING

- During thunderstorms, do not touch the antenna or the front panel. This may lead to electrical shock from lightning.

CAUTION

- Do not block ventilation holes or heat sinks on the product. Blocking ventilation holes or heat sinks may prevent heat from escaping from within the product, leading to fire or malfunction.
- Do not turn the volume up to the extent that you cannot hear sounds from outside the vehicle while driving. Driving without being able to hear sounds from outside the vehicle may result in an accident.
- Do not insert your hand or fingers into the disc slot. This may result in injury.

Operation Keys

E00737101277

Turn the Power ON/ OFF

E00737201249

1. Press the SEL•PWR•VOL key.

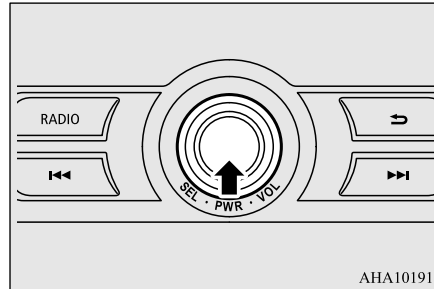

1. Turn the power on, and resume playback from the previous status.
2. Hold down the SEL•PWR•VOL key. Turn the power OFF.

NOTE

- Hold down the steering MODE button to also turn the audio function ON/OFF.

Adjust Volume

E00737301152

1. Turn the SEL•PWR•VOL key to adjust the volume.

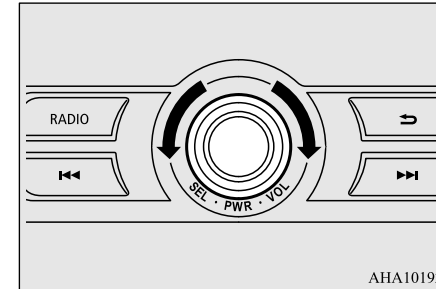

- Turn the SEL•PWR•VOL key clockwise to increase, and counter-clockwise to decrease the volume.

NOTE

- The maximum value for volume is “49”, and the minimum is “0”.
- The initial setting for volume is “17”.

Insert/Eject Discs

E00737401179

1. Insert the disc into the disc slot with the label surface up.

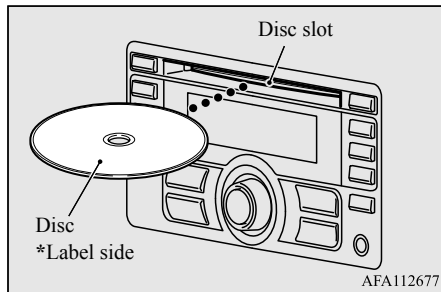

Push the disc in a certain amount, and the product will pull the disc in, and playback will start.

2. Press the ▲ key.

This will eject the disc from the product, so remove the disc.

⚠ CAUTION

- When replacing discs, first ensure that the vehicle is stopped in an area in which stopping is permitted.
- Do not insert your hand, fingers, or foreign objects into the disc slot. This may lead to injury, smoking, or fire.
- 8 cm CDs are not supported.

Operation Keys

Explanation of Buttons

E00737501460

This explains names and functions of each part.

7

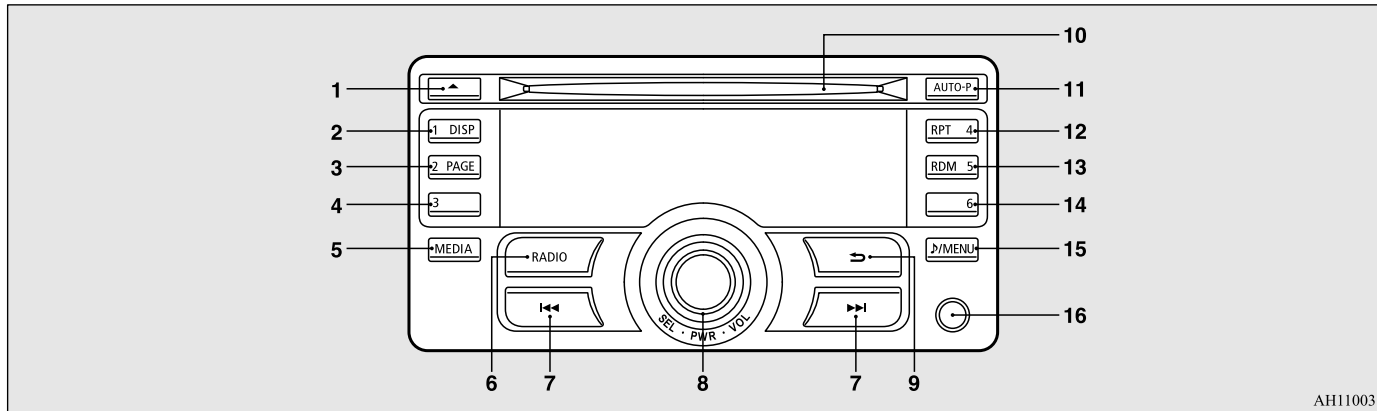

AH1100313

1- ▲ key

Use to eject a disc.

2- 1DISP key

Switch the content of the display.

For radio, use as preset key 1.

3- 2PAGE key

Display the content page forward.

For radio, use as preset key 2.

4- 3key

For radio, use as preset key 3.

5- MEDIA key

Each time this is pressed, the audio source switches in the order “CD”, “USB/iPod”, and “AUX”.

6- RADIO key

Switch the radio and the band.

7- ◀▶ key/ ▶▶ key

For audio, press to select audio track/file and hold down to rewind/fast forward;

for radio, select radio station.

8- SEL·PWR·VOL key

Adjust the volume, and turn the power ON/OFF. Additionally, adjust audio quality and select items.

9- ⏮ key

Return to the previous operation.

10- Disc slot

11- AUTO-P key

Auto preset the radio.

7-18 For pleasant driving

- 12- 4RPT key
For audio, press to turn repeat playback mode on/off; for radio, use as preset key 4.
- 13- 5RDM key
For audio, press to turn random playback mode on/off; for radio, use as preset key 5.
- 14- 6key
For radio, use as preset key 6.
- 15- /MENU key
Switch to Menu mode.
- 16- Auxiliary Audio connector (mini-jack)
Connect a commercially-available audio device.

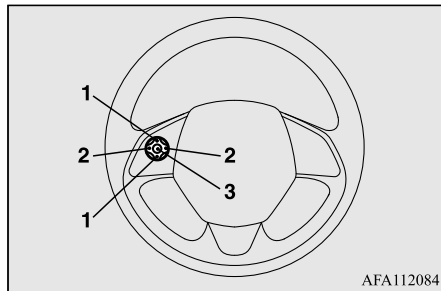

Steering wheel audio remote control switches

E00737601937



AFA112084

- 1- Volume up/down switch
Adjust audio functions volume.

- 2-  button,  button
Select CD and other audio source tracks and radio stations.
Hold down to fast forward and rewind.
- 3- MODE button
Hold down to turn the audio function ON/OFF. Additionally, each time this is pressed, this switches the audio source.
The order of switching is as shown below.

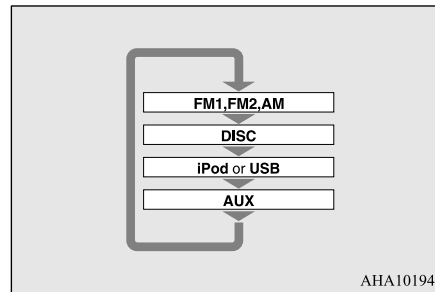

AHA101947

Listen to Radio

E00737701286

This explains how to listen to AM and FM radio broadcasts.

To Listen to the Radio



Press the RADIO key to switch the band.





Switch between AM and FM bands.
The selected band is indicated on the display.

NOTE

- Each time the RADIO key is pressed, this switches in the order “FM1”, “FM2”, and “AM”.

Manual/Seek Station Selection

Press the  key or the  key to the frequency to listen to.

 key	Increases the frequency being received.
 key	Reduces the frequency being received.
 key (hold down)	Release the button to start seek station selection, and when a station is received, scanning stops.
 key (hold down)	

Preset Memory

Register the broadcast station in advance, and select this at a later time.

- 1. Tune in to the frequency to register.

Listen to CDs

2. Hold down any of the keys from the 1DISP key to the 6 key.

A “Beep” sounds, and the preset key is registered.

NOTE

- The preset memory can register a maximum of 6 stations for each band.
- If a preset key that already has a station registered is selected, then this is overwritten with the new preset.
- Pressing the preset key will select the previously registered frequency.

Auto Preset

The top 6 stations with a strong signal can be automatically registered in order with preset keys in the AUTO-P mode.

Hold down the AUTO-P key.

Switch to the AUTO-P mode, and start automatic station selection.

After completion of operations, the product will receive the station registered in the preset key [1].

CAUTION

- Please be aware that the formerly-registered frequency in the memory will be overwritten.

NOTE

- Pressing the preset key will select the previously registered frequency.
- Each time the AUTO-P key is pressed, this switches between normal reception and AUTO-P mode.
- In the AUTO-P mode, manual/seek station selection, as well as scan operation is also possible.
- When strong signal is less than 6 stations, the minimum signal is registered in the remaining preset keys.

Listen to CDs

E00737801261

This explains how to listen to audio CDs (CD-DA/CD-TEXT).

Play CDs

Insert the disc.

Insert a disc to automatically start playback.
→ “Insert/Eject Discs” (P.7-16)

If a disc is already within the product, press the MEDIA key to switch to CD as the source.

Select the Track

Press the ◀◀ key or ▶▶ key to select the track.

This enables selection of the next or previous track.

Fast Forward or Rewind

Hold down the ◀◀ key or ▶▶ key.

Fast forward/rewind is possible.

Switch Playback Mode

Repeat playback and random playback are possible.

Repeat Playback (RPT)

Press the 4RPT key.

Repeat playback of the track currently being played.

NOTE

- Pressing again will cancel.
- Ejecting will cancel this.

Random Playback (RDM)

Press the 5RDM key.

Play the tracks on the disc in a random order.

NOTE

- Pressing again will cancel.
- Ejecting will cancel this.

Search Tracks

This enables search of the track while playing music.

1. Press the SEL•PWR•VOL key.
2. Turn the SEL•PWR•VOL key to select the track.
3. Press the SEL•PWR•VOL key.
This plays the selected track.

Listen to MP3s/WMA/AACs

E00737901259

This explains how to listen to audio files on a disc.

To Listen to MP3s/WMA/AACs

Insert the disc.

Insert a disc to automatically start playback. → “Insert/Eject Discs” (P.7-16)
If a disc is already within the product, press the MEDIA key to switch to CD as the source.

NOTE

- Depending on the file structure, it may take some time to read the contents of the disc.

Select the Track (File)

Press the ◀◀ key or ▶▶ key to select the track.

This enables selection of the next or previous track.

Fast Forward or Rewind

Hold down the ◀◀ key or ▶▶ key.

Fast forward/rewind is possible.

Switch Playback Mode

Repeat playback and random playback are possible.

Repeat Playback (RPT)

Press the 4RPT key.

Repeat playback of the track currently being played.

NOTE

- Pressing the 4RPT key two times will cancel.
- Ejecting will cancel this.

Folder Repeat Playback

Press the 4RPT key during repeat playback of a track.

Repeat playback of the tracks within the folder currently being played.

Listen to an iPod*

NOTE

- Pressing again will cancel.
- Ejecting will cancel this.
- Even if the file is selected, folder repeat playback will not be cancelled.

Random Playback (RDM)

Press the 5RDM key.

7

Play the tracks in the folder in a random order.

NOTE

- Pressing the 5RDM key two times will cancel.
- Ejecting will cancel this.

Folder Random Playback

Press the 5RDM key during playback of the tracks in the folder in a random order.

Play all tracks in folders on the disc in a random order.

NOTE

- Pressing again will cancel.

Search Tracks

Search folders and files, and select a track.



1. Press the SEL•PWR•VOL key.
2. Turn the SEL•PWR•VOL key to select the folder.
3. Press the SEL•PWR•VOL key.

Files within the selected folder are displayed.

4. Turn the SEL•PWR•VOL key to select the file.
5. Press the SEL•PWR•VOL key.

This plays the selected file (track).

NOTE

- While the folder is selected, press the  key to cancel track search mode.
- If there is no operation for 10 seconds after selecting the folder, then track search mode will be cancelled.
- While the file is selected, press the  key to return to the previous operation.
- While the file is selected, hold down the  key to cancel track search mode.
- Disc operations such as selecting a track will cancel track search mode.

Listen to an iPod*

E00738001606

By connecting commercially-available iPod/iPhone devices to this product, you can play tracks on these through the product.

CAUTION

- Do not leave the iPod/iPhone unattended in the vehicle.
- Never hold these devices in your hand to operate while driving, as this is dangerous.
- No indemnification for data loss resulting when the iPod/iPhone is connected to the product will be possible.
- Depending on how the devices are handled, audio files being damaged or lost, therefore it is recommended that data be backed up.

NOTE

- Depending on the generation, model, or software version of the iPod/iPhone, playback on this product may not be possible. (→P.7-10) Additionally, playback as explained in this document may not be possible.
- Usage of iPod/iPhone hardware with the latest software version is recommended.
- Regarding how to connect the iPod/iPhone, refer to “How to connect an iPod” on page 7-32.

NOTE

- When connecting the iPod/iPhone, use a commercially-available iPod connection cable.
- Set up the device in order that no unsafe actions, such as plugging in the connection cable are taken while driving.
- When inserting and removing the iPod/iPhone, for safety's sake first stop the vehicle.
- Depending on the status of the iPod/iPhone, it may take some time until the device is recognized, or playback starts.
- Depending on the iPod/iPhone, the button functions on the product may not operate while the iPod/iPhone is connected.
- iPod/iPhone specifications and settings may mean that connection is not possible, or result in differences in operation or display.
- Depending on audio data in the iPod/iPhone, track information may not be displayed correctly.
- Depending on the status of the vehicle and device, the iPod/iPhone may not be played after starting the engine.
- Data containing copyright information may not be played back.
- It is recommended that the iPod/iPhone equaliser settings be set to flat.
- Operate the iPod/iPhone while connected to this product.
- If an iPod/iPhone does not operate correctly, then remove the iPod/iPhone from the product, reset, then reconnect.

Play iPod

Press the MEDIA key to set the USB (iPod) as the source.

The selected source is indicated on the display.

Select the Track (File)

Press the ◀◀ key or ▶▶ key to select the track.

This enables selection of the next or previous track.

Fast Forward or Rewind

Hold down the ◀◀ key or ▶▶ key.

Fast forward/rewind is possible.

Switch Playback Mode

Repeat playback and shuffle playback are possible.

Repeat Playback (RPT)

Press the 4RPT key.

Repeat playback of the track currently being played.

NOTE

- Pressing again will cancel.

Shuffle Playback (RDM)

Press the 5RDM key.

Play tracks in the category currently being played in a random order.

NOTE

- Pressing the 5RDM key two times will cancel.

Album Shuffle Playback

Press the 5RDM key during playback of the album in a random order.

Play the album in a random order (tracks in any order on the album).

Listen to Audio Files on a USB Device*

NOTE

- Pressing again will cancel.



Search Tracks

Search categories or track names, and select a track.

7

1. Press the SEL•PWR•VOL key.
2. Turn the SEL•PWR•VOL key to select the category.
3. Press the SEL•PWR•VOL key. Categories or tracks within the selected category are displayed.
4. Turn the SEL•PWR•VOL key to select the category or track.
5. Press the SEL•PWR•VOL key.
Repeat steps 1 to 4, and search for tracks.
Select the track, and press the SEL•PWR•VOL key to play.

NOTE

- While the category (1st level) is selected, press the  key to cancel track search mode.
- If there is no operation for 10 seconds after selecting the category, then track search mode will be cancelled.
- While the track is selected, press the  key to return to the previous operation.

NOTE

- While the track is selected, hold down the  key to cancel track search mode.
- iPod operations such as selecting a track will cancel track search mode.

Listen to Audio Files on a USB Device*

E00736501623

By connecting commercially-available USB devices such as USB memory to this product, you can play audio files on these through the product.

CAUTION

- Do not leave the USB device unattended in the vehicle.
- Never hold these devices in your hand to operate while driving, as this is dangerous.
- Do not use hard discs, card readers, or memory readers, as damage may occur to these or to the data contained therein. If these are erroneously connected, then turn the ignition switch to the “LOCK” position or put the operation mode in OFF, then remove.
- Because of the risk of data loss, it is recommended that files be backed up.
- No guarantee is made as regards damage to the USB device, nor regarding loss or damage to data contained therein.

CAUTION

- Depending on how the devices are handled, audio files being damaged or lost, therefore it is recommended that data be backed up.

NOTE

- Digital audio players that support the mass storage class specifications can be connected.
- Regarding how to connect USB devices, refer to “How to connect a USB memory device” on page 7-31.
- When connecting a USB device, use a connection cable. Failure to use a connection cable when connecting may place undue load on, or damage the USB connector.
- Set up the device in order that no unsafe actions, such as plugging in the connection cable are taken while driving.
- When inserting and removing the USB device, for safety’s sake first stop the vehicle.
- Do not insert other than audio devices into the USB port. Damage to the device or equipment may result.
- Depending on the status of the USB device, it may take some time until the device is recognized, or playback starts.
- Depending on the USB device, the button functions on the product may not operate while the USB device is connected.

 **NOTE**

- USB device specifications and settings may mean that connection is not possible, or result in differences in operation or display.
- Depending on audio data in the USB device, track information may not be displayed correctly.
- Depending on the status of the vehicle and device, the iPod/iPhone may not be played after starting the engine.
- Data containing copyright information may not be played back.
- This product can play MP3, WMA, and AAC format audio files.
- Depending on the type of USB device, usage may not be possible, or functions that can be used may be restricted.
- The recommended file system for USB memory is FAT32.
- The maximum supported capacity for USB memory is 32GB.
- Operate the USB device containing recorded audio files while connected to this product.

Playback of Audio Files on a USB Device

Press the MEDIA key to set

USB as the source. The selected source is indicated on the display.

Select the Track (File)

Press the ◀◀ key or ▶▶ key to select the track.

This enables selection of the next or previous track.

Fast Forward or Rewind

Hold down the ◀◀ key or ▶▶ key.

Fast forward/rewind is possible.

Switch Playback Mode

Repeat playback and random playback are possible.

Repeat Playback (RPT)

Press the 4RPT key.

Repeat playback of the track currently being played.

 **NOTE**

- Pressing the 4RPT key two times will cancel.

Folder Repeat Playback

Press the 4RPT key during repeat playback of a track.

Repeat playback of the tracks within the folder currently being played.

 **NOTE**

- Pressing again will cancel.
- Even if the file is selected, folder repeat playback will not be cancelled.

Folder Random Playback (RDM)

Press the 5RDM key.

Play tracks in the folder currently being played in a random order.

 **NOTE**

- Pressing the 5RDM key two times will cancel.

All Folder Random Playback

Press the 5RDM key during playback of the tracks in the folder in a random order.



Use AUX*

Play the tracks in all folders in a random order.

NOTE

- Pressing again will cancel.
- Even if the file is selected, all folder random playback will not be cancelled.

NOTE

- While the file is selected, press the  key to return to the previous operation.
- While the file is selected, hold down the  key to cancel track search mode.
- Operations such as selecting a track will cancel track search mode.

CAUTION

- Connect an audio device with external sound input mode canceled, or with the sound turned down.
- Even if not inserted, the product will switch to AUX, therefore take care with volume levels when not inserted.

Search Tracks

7

Search folders and files, and select a track.

1. Press the SEL•PWR•VOL key.
2. Turn the SEL•PWR•VOL key to select the folder.
3. Press the SEL•PWR•VOL key.
Files within the selected folder are displayed.
4. Turn the SEL•PWR•VOL key to select the file.
5. Press the SEL•PWR•VOL key.
This plays the selected file (track).

NOTE

- While the folder is selected, press the  key to cancel track search mode.
- If there is no operation for 10 seconds after selecting the folder, then track search mode will be cancelled.

Use AUX*

E00736901210

By connecting external input cables and AUX devices to this product, you can play tracks on these devices through the product.

Press the MEDIA key to switch to the AUX mode.

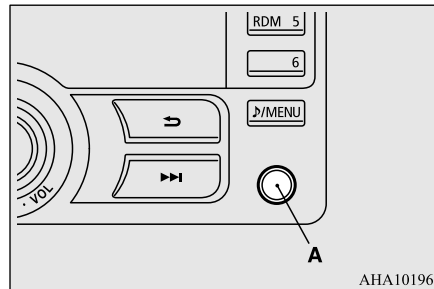

A- Auxiliary Audio connector (mini-jack)

NOTE

- Depending on the audio device to be connected, noise may be emitted.
- For power, use the battery power source included in the audio device to be connected. Using the connected audio device while charging through the cigarette lighter socket in the vehicle may lead to noise being emitted through the speakers.
- If no audio devices are connected, then do not select the external sound input mode. If external sound input mode is selected while no audio devices are connected, then sound may be emitted through the speakers.

Display Indicator

E00738101232

This explains content of the display indicator.

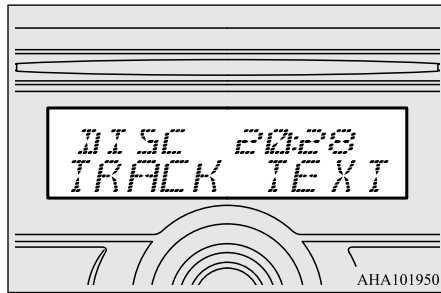

Change the Display Mode

E00738501278

You can change the content of the display indicator.

Press the 1DISP key to switch the display content.

Each time the 1DISP key is pressed, the display content changes.

CAUTION

- The operation of changing display contents may impede safe driving, therefore check safety before operation.

NOTE

- Up to 10 characters may be displayed at one time. To display 11 or more characters, press the 2PAGE key, and subsequent characters will be displayed.

During CD-DA playback

This switches in the order “Track No. + playtime”, “Disc text” and “Track text”.

NOTE

- If there is no artist text information to display, then “Track No. + playtime” is displayed.
- If there is no album text information to display, then “DISC TEXT” is displayed.
- If there is no song text information to display, then “TRACK TEXT” is displayed.

During MP3/WMA/AAC Playback

This switches in the order “Track No. + Playtime”, “Folder no/File no”, “Folder text”, “File text”, “Artist text”, “Album text” and “Song text”.

NOTE

- If there is no artist text information to display, then “ARTIST” is displayed.
- If there is no album text information to display, then “ALBUM” is displayed.
- If there is no song text information to display, then “SONG” is displayed.

During iPod Playback

E00738901155

7

During other than Podcast playback, this switches in the order “Track No. + playtime”, “Artist text”, “Album text” and “Song text”.

During Podcast playback, this switches in the order “Track No. + playtime”, “Podcast name”, “Episode name” and “Release date”.

NOTE

- If there is no artist text information to display, then “ARTIST” is displayed.
- If there is no album text information to display, then “ALBUM” is displayed.
- If there is no song text information to display, then “SONG” is displayed.

Audio Quality and Volume Balance Adjustment

E00738201419

Change audio quality settings.

For pleasant driving 7-27

Time Setting

Adjust Audio Quality and Volume Balance

1. Press the **▶**/MENU key.
2. Turn the SEL•PWR•VOL key to select adjustment items and press the SEL•PWR•VOL key.
Turning the SEL•PWR•VOL key counter-clockwise or clockwise, the adjustment items switch as shown below.
BASS↔TREBLE↔FADER↔BAL-ANCE
3. Turn the SEL•PWR•VOL key to adjust the adjustment items selected.

Adjustment items	Turn counter-clockwise	Turn clockwise
BASS	-5~0 (Decrease low frequency volume)	0~+5 (Increase low frequency volume)
TREBLE	-5~0 (Decrease high frequency volume)	0~+5 (Increase high frequency volume)
FADER	R11~0 (Emphasise REAR)	0~F11 (Emphasise FRONT)

Adjustment items	Turn counter-clockwise	Turn clockwise
BAL-ANCE	L11~0 (Emphasise LEFT)	0~R11 (Emphasise RIGHT)

Time Setting

E00770700077

This explains how to set time.

1. Hold down the **▶**/MENU key.
2. Turn the SEL•PWR•VOL key to select “CLOCK MODE” or “CLOCK ADJUST MODE”.
3. Press the SEL•PWR•VOL key to complete.
The selected item is indicated on the display.

CLOCK MODE

This enables selection of the 12-hour clock or the 24-hour clock.

1. Turn the SEL•PWR•VOL key to select the 12-hour clock or the 24-hour clock.
2. Press the SEL•PWR•VOL key to complete and the clock display is changed.

CLOCK ADJUST MODE

Set the time manually.

1. Turn the SEL•PWR•VOL key to adjust the hour.
2. Press the SEL•PWR•VOL key to set the hour then shift to adjust the minutes.
3. Turn the SEL•PWR•VOL key to adjust the minutes.
4. Press the **▶**/MENU key.
This completes the adjustment.

Troubleshooting

E00738401349

Please check these items if a message appears on the display, or if you think something is not working properly.

If This Message Appears...

A message is displayed on this product according to the situation.

Mode	Message	Cause	Response
CD	DISC_ERROR	The disc is damaged and/or dirty.	Clean the read surface of the disc.
	EJECT_E	The disc cannot be ejected.	Wait a while before ejecting again. If the problem persists, consult an authorised MITSUBISHI MOTORS dealer.
	UNSUPPORT	Unsupported audio files have been played.	Confirm audio files that can be played. → “Audio files (MP3/WMA/AAC)” (P.7-12)
	PROTECT	Audio files protected by DRM (Digital Rights Management) have been played.	Use audio files without DRM (Digital Rights Management).
	COM_ERROR	Reading the contents of the CD has malfunctioned for some reason.	Turn the power OFF and wait a while. If the problem persists, consult an authorised MITSUBISHI MOTORS dealer.

7

Antenna*

7

Mode	Message	Cause	Response
USB	NO _ FILE	There are no audio files that can be played.	Confirm audio files that can be played. → “Audio files (MP3/WMA/AAC)” (P.7-12)
	DEVICE _ ERR	An unsupported USB device has been connected.	Confirm the USB device.
	BUS_POWER	There is high electrical current.	Confirm the USB device.
	UNSUPPORT	Unsupported audio files have been played.	Select audio files that can be played. → “Audio files (MP3/WMA/AAC)” (P.7-12)
	PROTECT	Audio files protected by DRM (Digital Rights Management) have been played.	Select audio files that can be played. → “Audio files (MP3/WMA/AAC)” (P.7-12)
	COM_ERROR	Reading the contents of the USB has malfunctioned for some reason.	Turn the power OFF and wait a while. If the problem persists, consult an authorised MITSUBISHI MOTORS dealer.
iPod	NO _ SONG	An iPod/iPhone not containing any tracks has been connected.	Connect an iPod/iPhone containing tracks.
	DEVICE _ ERR	Audio data in the iPod/iPhone cannot be read.	Confirm the iPod/iPhone that can be used. → “Trademarks” (P.7-10)
	BUS_POWER	There is high electrical current.	Confirm the USB device.
	AUT-ERROR	iPod/iPhone is not recognized correctly.	Confirm the iPod/iPhone.
	COM_ERROR	Reading the audio data in the iPod/iPhone has malfunctioned for some reason.	Turn the power OFF and wait a while. If the problem persists, consult an authorised MITSUBISHI MOTORS dealer.
	VER_ERROR	This iPod/iPhone software version is not supported.	Please change to a supported software version.

Antenna*

E00710502013

To remove

Turn the pole (A) anticlockwise.

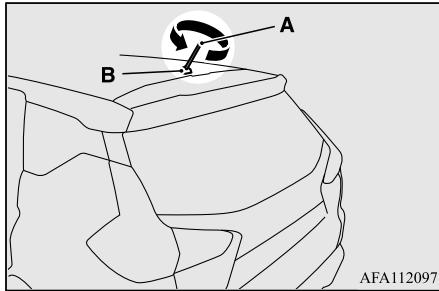

To install

Screw the pole (A) clockwise into the base (B) until it is securely retained.

NOTE

- Be sure to remove the pole antenna in the following cases:
 - When going into an automatic car wash.
 - When placing a car cover over the vehicle.
 - When driving into a structure that has a low ceiling.

Link System*

E00764501934

The Link System takes overall control of the devices connected via the USB input terminal

allowing the connected devices to be operated by using the switches in the vehicle. Refer to “USB input terminal” on page 7-31.

USB input terminal*

E00761901852

You can connect your USB memory device or iPod* to play music files stored in the USB memory device or iPod.

This section explains how to connect and remove a USB memory device or iPod.

See the following section for details on how to play music files.

Refer to “Listen to an iPod” on page 7-22.

Refer to “Listen to Audio Files on a USB Device” on page 7-24.

*: “iPod” is a registered trademark of Apple Inc. in the United States and other countries.

How to connect a USB memory device

E00762001805

1. Park your vehicle in a safe place and turn the ignition switch to the “LOCK” position or put the operation mode in OFF.

2. Open the USB input terminal cover (A) on the centre console.

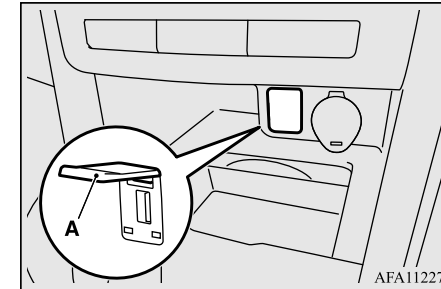

3. Connect a commercially available USB connector cable (C) to the USB memory device (B).

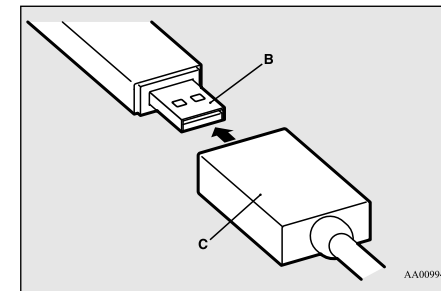

USB input terminal*

4. Connect the USB connector cable (C) to the USB input terminal (D).

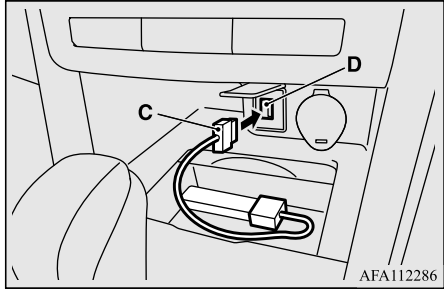

7

NOTE

- Do not connect the USB memory device to the USB input terminal directly. The USB memory device may be damaged.

5. To remove the USB connector cable, turn the ignition switch to the “LOCK” position or put the operation mode in OFF first and perform the installation steps in reverse.

CAUTION

- After removing the USB connector cable, be sure to close the terminal cover. Entry of foreign matter into the terminal may cause a malfunction.

How to connect an iPod

E00762101851

1. Park your vehicle in a safe place and turn the ignition switch to the “LOCK” position or put the operation mode in OFF.
2. Open the USB input terminal cover (A) on the centre console.

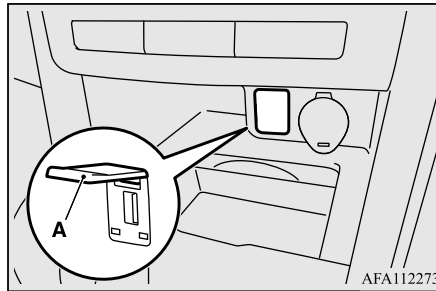

3. Connect the connector cable to the iPod.

NOTE

- Use a genuine connector cable from Apple Inc.

4. Connect the connector cable (B) to the USB input terminal (C).

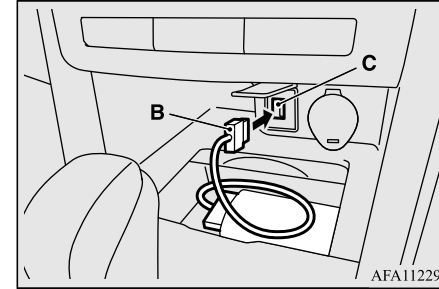

5. To remove the connector cable, turn the ignition switch to the “LOCK” position or put the operation mode in OFF first and perform the installation steps in reverse.

CAUTION

- After removing the USB connector cable, be sure to close the terminal cover. Entry of foreign matter into the terminal may cause a malfunction.

Types of connectable devices and supported file specifications

E00762201575

For details about the types of connectable devices and supported file specifications, refer to the following pages and manuals.

[For vehicles equipped with the AM/FM radio/CD player with AUX]

Refer to “Listen to an iPod” on page 7-22, “Listen to Audio Files on a USB Device” on page 7-24 and “Audio Files (MP3/WMA/AAC)” on page 7-12.

[For vehicles equipped with the Display audio]

Refer to the separate owner’s manual.

Sun visors

E00711202831

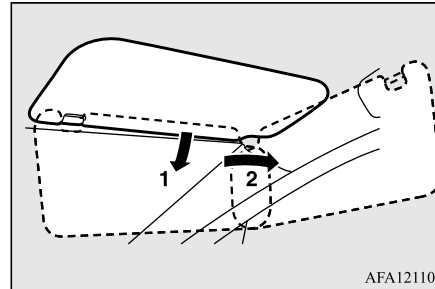

AFA121107

- 1- To eliminate front glare
- 2- To eliminate side glare

Vanity mirror

A vanity mirror is fitted to the back of the sun visor.

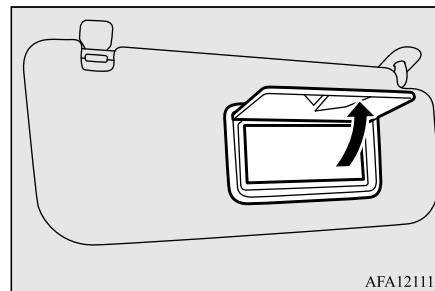

AFA121110

Ticket holder

The holder (A) is located on the back of the sun visor.

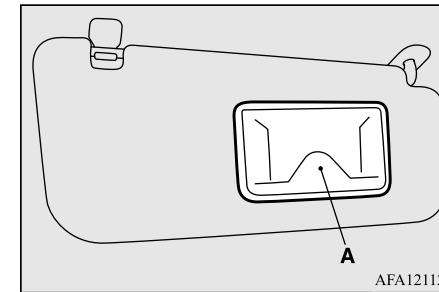

AFA121123

7

CAUTION

- Do not leave plastic cards in the ticket holder. Because the inside of the vehicle will become hot if the vehicle is parked in strong sunlight, the cards could deform or crack.

Accessory socket

Accessory socket

E00711603340

CAUTION

- Be sure to use a “plug-in” type accessory operating at 12 V and at 120 W or less. When using more than one socket at the same time, make sure that the electrical accessories are 12 V accessories and that the total power consumption does not exceed 120 W.
- Long use of the electric appliance without running the engine may run down the battery.
- When the accessory socket is not in use, be sure to close the lid or install the cap, because the socket might become clogged by foreign material and be short-circuited.

To use a plug-in type accessory, remove the cap, and insert the plug in the accessory socket.

NOTE

- Accessory sockets in 3 locations can be used at the same time.

The accessory socket can be used while the ignition switch or the operation mode is in ON or ACC.

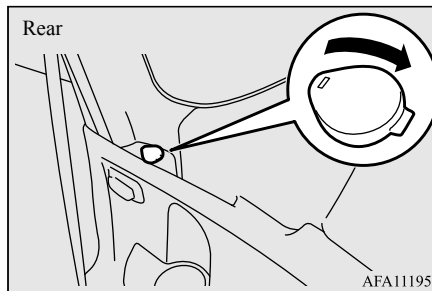
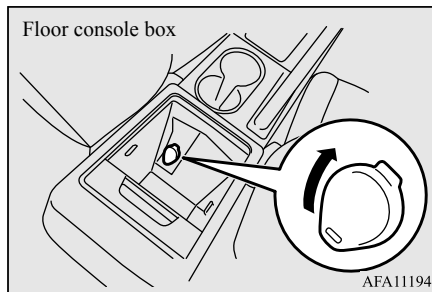
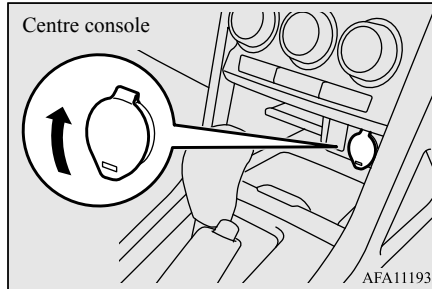

Room lamps

E00712003051

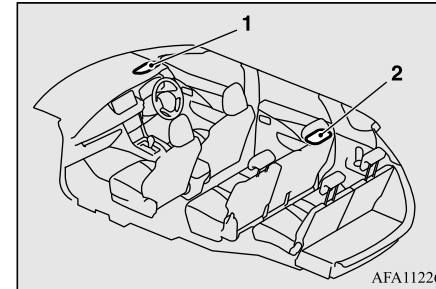

- 1- Room lamp (front)
- 2- Room lamp (rear)

NOTE

- If you leave the lamps on without running the engine, you will run down the battery. Before you leave the vehicle, make sure that all the lamps are off.

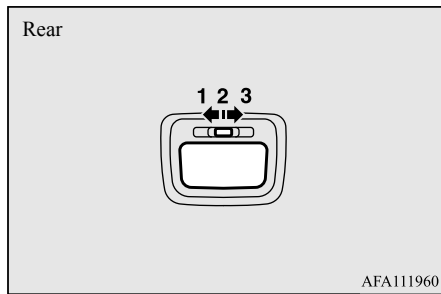
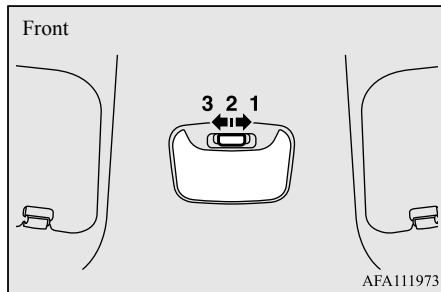

Position of lamp switch	On/off control
1- (☺)	The lamps illuminate regardless of whether a door or the tailgate is open or closed.

Position of lamp switch	On/off control
2- Door (●)	<p>Delayed off function</p> <p>The lamps illuminate when a door or the tailgate is opened. It goes off approximately 15 seconds after all doors and the tailgate are closed. However, the lamp goes off immediately with all doors and the tailgate closed in the following cases:</p> <ul style="list-style-type: none"> ● When the ignition switch is turned to the “ON” position or the operation mode is put in ON. ● When the central door lock function is used to lock the vehicle. ● When the keyless entry key or the keyless operation key is used to lock the vehicle. ● If the vehicle is equipped with the keyless operation system, when the keyless operation function is used to lock the vehicle.

Position of lamp switch	On/off control
	<p>Auto cut-out function</p> <p>If the lamps are left switched on with the ignition switch in the “LOCK” or “ACC” position or the operation mode is in OFF or ACC, and a door or the tailgate is opened, it goes off automatically after approximately 30 minutes. The lamp will illuminate again after it automatically goes off in the following cases:</p> <ul style="list-style-type: none"> ● When the ignition switch is turned to the “ON” position or the operation mode is put in ON. ● When the keyless entry system or the keyless operation system is operated. ● When all doors and the tailgate are closed.
3- OFF (○)	The lamps go off regardless of whether a door or the tailgate is open or closed.

Storage spaces

NOTE

- When the ignition key is removed or the operation mode is put in OFF while the doors and the tailgate are closed, the lamp illuminates and after approximately 15 seconds it goes off.
- The time until the lamp goes off (delayed off) can be adjusted. For details, please consult an authorised MITSUBISHI MOTORS dealer.
- The auto cut-out function cannot be operated when the front room lamp switch is in the  position. Also, this function can be deactivated. For details, please consult an authorised MITSUBISHI MOTORS dealer.

7

Storage spaces

E00713103684

CAUTION

- Never leave lighters, canned carbonated beverage, and spectacles in the cabin when parking the vehicle in hot sunshine. The cabin will become extremely hot, so lighters and other flammable items may catch fire and unopened drink cans may rupture. Also, spectacles with plastic lenses or materials could deform or crack.
- Keep the lids on storage spaces closed while driving the vehicle. A lid or the contents of a storage space could otherwise cause injuries.

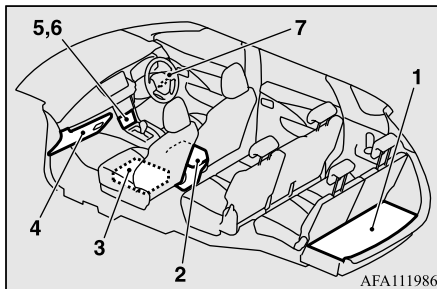

- 1- Luggage floor box
- 2- Floor console box
- 3- Passenger's seat under tray
- 4- Glove box
- 5- Instrument panel lower tray
- 6- Instrument panel lower secret box
- 7- Driver's side instrument panel lower box

Glove box

E00726201395

To open, pull the lever (A).

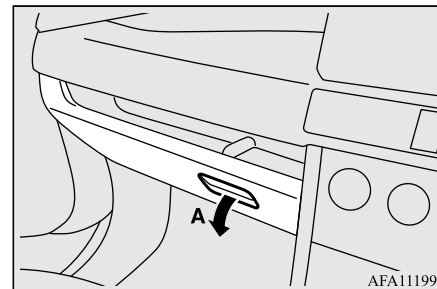

Driver's side instrument panel lower box

E00777400057

To open, pull the lever (A).

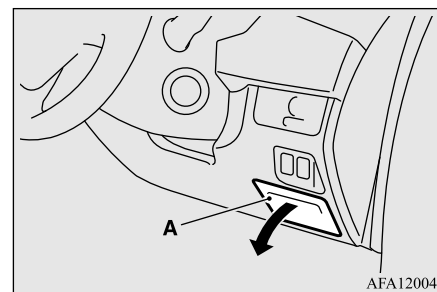

Instrument panel lower tray

E00777500032

The instrument panel lower tray is on the centre console part.

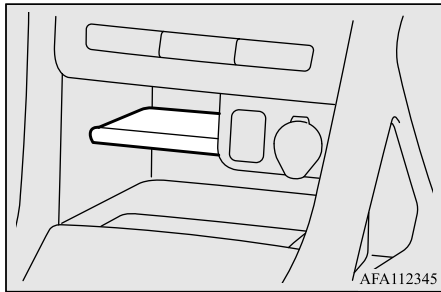

NOTE

- Pull the partition (A) of the instrument panel lower tray rearward to remove it. Store the removed partition carefully so that it is not lost.

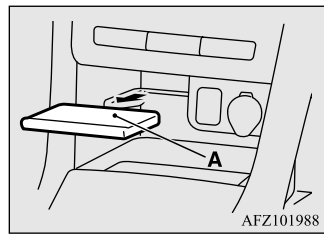

Instrument panel lower secret box

E00777600033

The instrument panel lower secret box is a small storage compartment with a cover that is located on the bottom of the centre console. To open the instrument panel lower secret box, place your finger on the cover handle (A) of the cover and push.

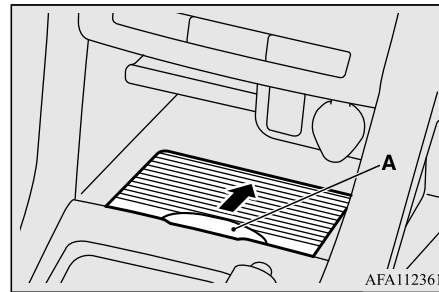

NOTE

- Cables for USB devices can pass through the opening (B) near the cover handle (A).

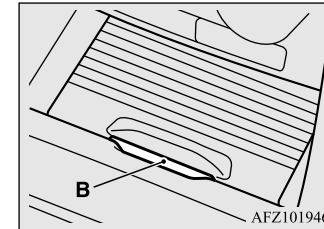

- Do not use the instrument panel lower secret box as an ashtray. This could cause a fire or the tray will be damaged.

7

Floor console box

E00723302608

To open the floor console box, place your finger on the handle (A) of the cover and push slowly.

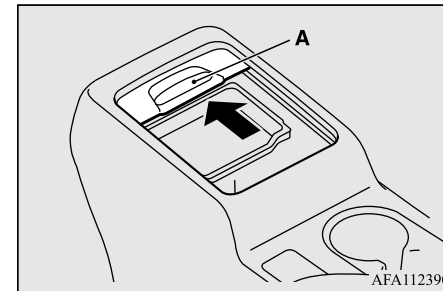

Storage spaces

NOTE

- The tray (B) can be removed. The removed tray can be stored in the floor console box.

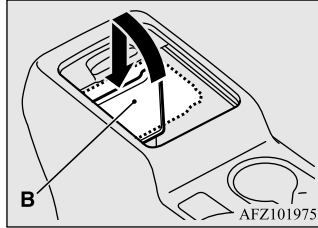

7

Luggage floor box

E00718702037

The box for storing articles is located inside the luggage compartment.

To use the box, raise the luggage floor board. Pull the strap (A) upward to lift the luggage floor board.

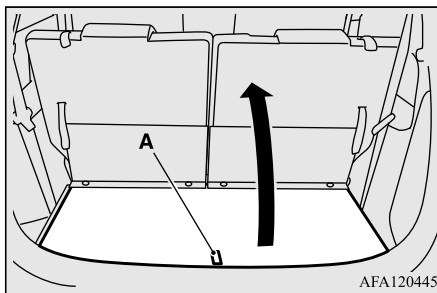

The spaces on the left and right sides of the luggage floor box can be used to store small items.

Passenger's seat under tray

E00725701058

To use this tray, lift it slightly and pull it forward.

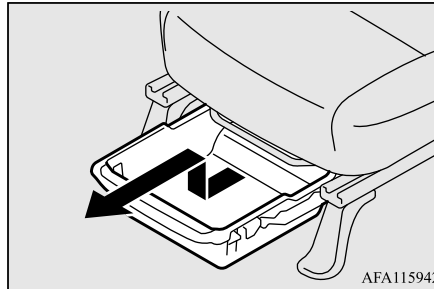

NOTE

- When using the tray from the rear seat, lift the tray slightly and pull it rearward.

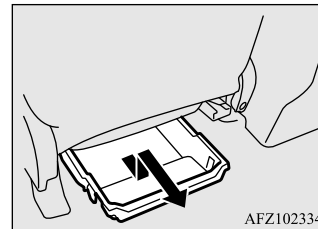

Removing and installing the tray

To remove the tray, pull the tray forward until it stops, and then pull it out from the rails while pushing the left and right hooks securing the tray to the rails.

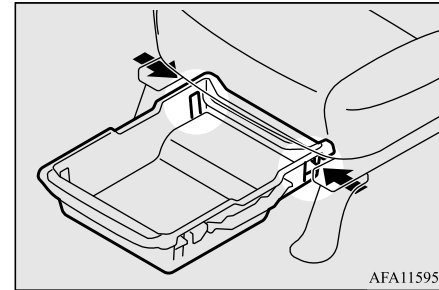

To install the tray, align the left and right hooks with the rails, and then slide the tray onto the rails.

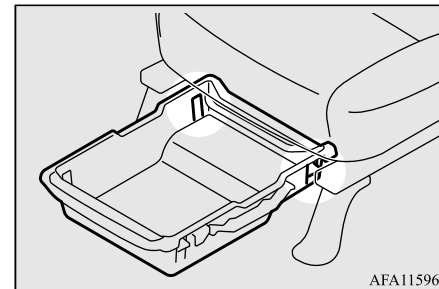

NOTE

- The tray can be removed and installed from the front or rear of the passenger seat.

CAUTION

- Be sure to push the tray in until it is locked in place so that it does not open while you are driving.
- Do not place items with a total weight of 2 kg or more in the tray. The items could fly out of the tray during sudden braking, resulting in an accident.
- Do not open or close the tray while driving. Otherwise, an accident could result.

Drink holder

E00714502587

WARNING

- Do not spray water or spill beverages inside the vehicle. If the switches, wires, or electrical components become wet, they could malfunction or cause a vehicle fire. If you accidentally spill a beverage, wipe up as much liquid as possible and immediately consult an authorised MITSUBISHI MOTORS dealer.

CAUTION

- Do not drink beverages while driving. This is distracting and could cause an accident.

For the front seat

The drink holder is located between the front seats.

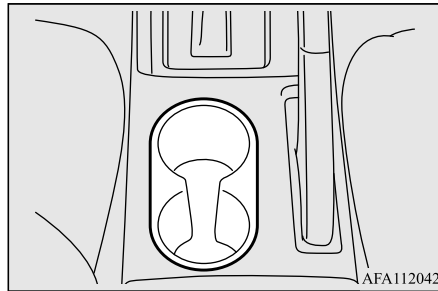

For the third seat

E00719001173

The drink holder is located at the both side of the third seat.

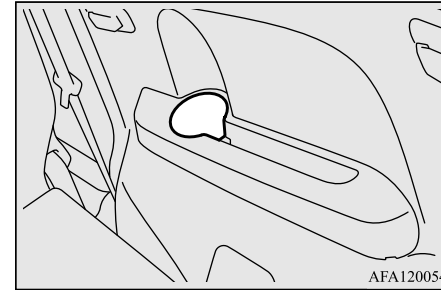

Bottle holder

E00718201716

WARNING

- Do not spray water or spill beverages inside the vehicle. If the switches, wires, or electrical components become wet, they could malfunction or cause a vehicle fire. If you accidentally spill a beverage, wipe up as much liquid as possible and immediately consult an authorised MITSUBISHI MOTORS dealer.

CAUTION

- Do not drink beverages while driving. This is distracting and could cause an accident.
- Drinks could be spilled by the vibration and jolts while driving. If the spilt drink is very hot, you could be burnt.

Convenient hook

There are bottle holders located on both sides of front and rear doors.



7

NOTE

- Do not store cup or drink can in the bottle holder.
- Tightly close the cap on drink bottles before storing them.
- Some bottles may be too big or the wrong shape to fit in the holder.

Convenient hook

E00732901397

Light items of luggage can be hung from the hook.

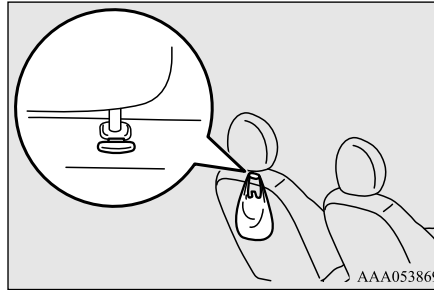

CAUTION

- Do not hang heavy luggage (more than approximately 5 kg) on the hook. Doing so could cause damage to the hook.

Assist grips

E00732801514

The assist grips (located above the doors on the headliner) are not designed to support body weight. They are intended for use only while seated in the vehicle.

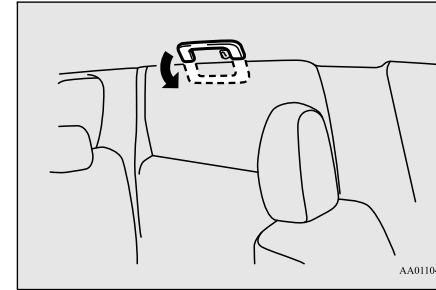

CAUTION

- Do not use the assist grips when getting into or out of the vehicle. The assist grips could detach causing you to fall.

Coat hook

E00725601813

There is a coat hook on the second seat assist grip of the both side.

Coat hook

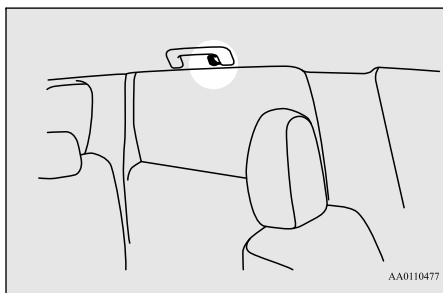

7

For pleasant driving 7-41



For emergencies

If the vehicle breaks down	8-2
If the operation mode cannot be changed to OFF (vehicles equipped with the keyless operation system)	8-2
Emergency starting	8-2
Engine overheating	8-3
Tools and jack	8-5
How to change a tyre	8-6
Towing	8-12
Operation under adverse driving conditions	8-15

If the vehicle breaks down

If the vehicle breaks down

E00800102479

If the vehicle breaks down on the road, move it to the shoulder and use the hazard warning flashers and/or the warning triangle etc. Refer to “Hazard warning flasher switch” on page 5-41.

If the engine stops/fails

8

Vehicle operation and control are affected if the engine stops. Before moving the vehicle to a safe area, be aware of the following:

- The brake booster becomes inoperative and the pedal effort will increase. Press down the brake pedal harder than usual.
- Since the power steering system is no longer operative, the steering wheel feels heavy when turning it.

If the operation mode cannot be changed to OFF (vehicles equipped with the keyless operation system)

E00804900468

If the operation mode cannot be changed to OFF, perform the following procedure.

8-2 For emergencies

1. Move the selector lever to the “P” (PARK) position, and then change the operation mode to OFF.
2. One of the other causes could be low battery voltage. If this occurs, the keyless entry system, keyless operation function, and steering lock will also not operate. Contact an authorised MITSUBISHI MOTORS dealer.

Emergency starting

E00800504839

If the engine cannot be started because the battery is partially or fully discharged, the battery from another vehicle can be used with jumper cables to start the engine.

WARNING

- To start the engine using jumper cables from another vehicle, perform the correct procedures according to the instruction below. Incorrect procedures could result in a fire or explosion or damage to the vehicles.
- Keep sparks, cigarettes and flames away from the battery because the battery may produce an explosion.

CAUTION

- Do not attempt to start the engine by pulling or pushing the vehicle. It could damage your vehicle.
- Check the other vehicle. It must have a 12-volt battery. If the other system isn't 12-volt, shorting can damage both vehicles.
- Use the proper cables suitable for the battery size to prevent overheating of the cables.
- Check the jumper cables for damage and corrosion before use.
- Always wear protective eye goggles when working near the battery.
- Keep the battery out of the reach of children.

1. Get the vehicles close enough so the jumper cables can reach, but be sure the vehicles aren't touching each other.
2. Turn off all lamps, heater and other electrical loads.
3. Set the parking brake firmly on each vehicle. Put an A/T or CVT in “P” (PARK) or a M/T in “N” (Neutral). Stop the engine.

WARNING

- Turn off the ignition on both vehicles beforehand. Make sure that the cables or your clothes cannot be caught by the fan or drive belt. Personal injury could result.

4. Make sure battery electrolyte is at the proper level.

Refer to “Battery” on page 10-8.

⚠ WARNING

- If electrolyte fluid is not visible, or appears to be frozen, Do Not Attempt Jump Starting!

A battery might rupture or explode if the temperature is below the freezing point or if it is not filled to the proper level.

- Electrolyte is corrosive diluted sulphuric acid.

If electrolyte (battery acid) comes into contact with your hands, eyes, clothes or the painted surface of your vehicle, it should be thoroughly flushed with water. If electrolyte gets in your eyes, flush them with water immediately and thoroughly, and get prompt medical attention.

5. Connect one end of one jumper cable ① to the positive (+) terminal of the discharged battery (A), and the other end ② to the positive (+) terminal of the booster battery (B).

Connect one end of the other jumper cable ③ to the negative (-) terminal of the booster battery, and the other end ④ to the appointed position (shown in the illustration) of the vehicle with the discharged battery at the point farthest from the battery.

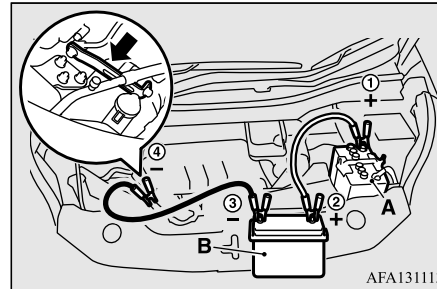

⚠ WARNING

- Make sure that the connection ④ is made to the appointed position (shown in the illustration). If the connection is made directly to the negative (-) side of the battery, the inflammable gases generated from the battery might catch fire and explode.
- When connecting the jumper cables, do not connect the positive (+) cable to the negative (-) terminal. Otherwise sparks might cause explosion of the battery.

⚠ CAUTION

- Use care not to get the jumper cable caught in the cooling fan or other rotating part in the engine compartment.

Engine overheating

6. Start the engine in the vehicle which has the booster battery, let the engine idle a few minutes, then start the engine in the vehicle with the discharged battery.

⚠ CAUTION

- Keep the engine of the vehicle giving assistance running.

7. After the engine is started, disconnect the cables in the reverse order and keep the engine running for several minutes.

📖 NOTE

- If the vehicle is put in motion without fully charging the battery, it might cause the loss of the smooth engine operation and the anti-lock brake warning lamp to illuminate. Refer to “Anti-lock brake system (ABS)” on page 6-29.



8

Engine overheating

E00800604524

When the engine is overheating, the warning will be displayed in the instrument cluster as follows.

Engine overheating

- The information screen in the multi-information display will be interrupted and the engine coolant temperature warning display will appear. Also “” will blink. (TFT colour LCD)
- “” will blink. (Mono-tone LCD)

If this occurs, take the following corrective measures:

1. Stop the vehicle in a safe place.
2. Check whether steam is coming from the engine compartment.

8

[If steam does not come from the engine compartment]

With the engine still running, raise the bonnet to ventilate the engine compartment.

[If steam is coming from the engine compartment]

Stop the engine, and when the steam stops, raise the bonnet to ventilate the engine compartment. Restart the engine.

WARNING

- Do not open the bonnet while steam is coming from the engine compartment. It could cause steam or hot water to spurt out, causing burns. Hot water could spurt out even when there is no steam coming out, and some parts will be very hot. Be very careful when opening the bonnet.
- Be careful of hot steam, which could be blowing off the reserve tank cap.
- Do not attempt to remove the radiator cap while the engine is hot.

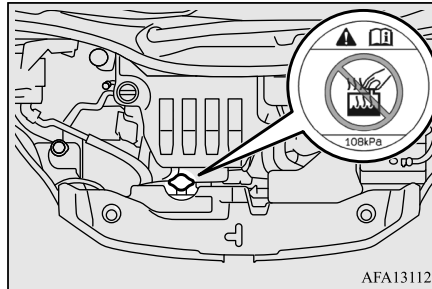

3. Confirm that the cooling fan (A) is turning.

[If the cooling fan is turning]

After the high coolant temperature warning has gone off, stop the engine.

[If the cooling fan is not turning]

Stop the engine immediately and contact an authorised MITSUBISHI MOTORS dealer for assistance.



*: Front of the vehicle

WARNING

- Be careful not to get your hands or clothes caught in the cooling fan.
- Because the resistor (B) may be hot even if the cooling fan has stopped, do not touch the resistor. Burns could result.

4. Check the coolant level in the reserve tank (C).

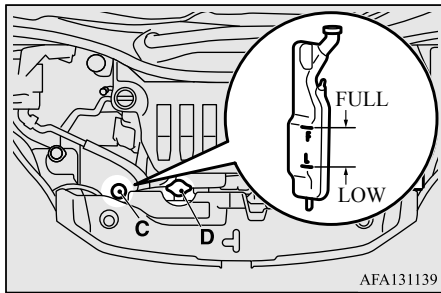

5. Add coolant to the radiator and/or reserve tank if necessary. (Refer to the “Maintenance” section.)

⚠ WARNING

- Make sure that the engine has cooled down before removing the radiator cap (D), because hot steam or boiling water otherwise will gush from the filler port and may scald you.

⚠ CAUTION

- Do not add coolant while the engine is hot. Suddenly adding cold coolant could damage the engine. Wait for the engine to cool down, then add coolant a little at a time.

6. Examine the radiator hoses for coolant leakage and the drive belt for looseness or damage.

If there is anything wrong with the cooling system or drive belt, we recommend you to have it checked and repaired.

Tools and jack

E00800902839

Storage

The tools and jack are stowed on the right side of the luggage area. The storage location of the tools and jack should be remembered in case of an emergency.

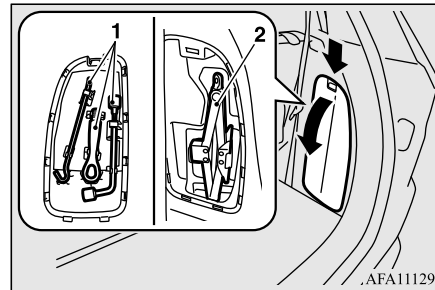

- 1- Tools
- 2- Jack

Tools

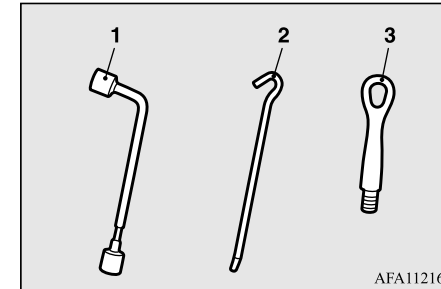

- 1- Wheel nut wrench
- 2- Jack bar
- 3- Towing hook

8

Jack

To remove

1. Remove the jack lid.
2. Retract the jack and remove it from its installation fitting (A).

How to change a tyre

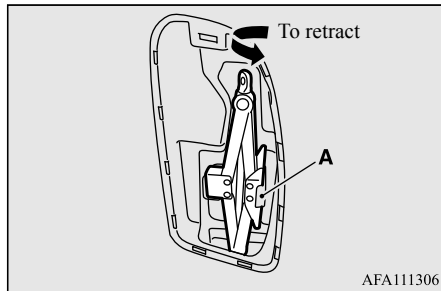

8 To store

1. Retract the jack, then return it to its original position.
2. Extend the jack and firmly secure it, then install the jack lid.

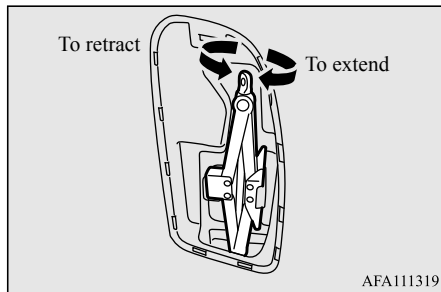

How to change a tyre

E00801204383

Before changing a tyre, first stop your vehicle in a safe, flat location.

1. Park the vehicle on level and stable ground, free of loose pebbles, etc.
2. Set the parking brake firmly.
3. Move the selector lever to the “P” (PARK) position and stop the engine.
4. Turn on the hazard flashers and set up a warning triangle, flashing signal lamp, etc., at an adequate distance from the vehicle, and have all your passengers leave the vehicle.
5. To prevent the vehicle from rolling when jacking up the vehicle, place chocks or blocks (A) at the tyre that is diagonally opposite from the tyre (B) you are changing.

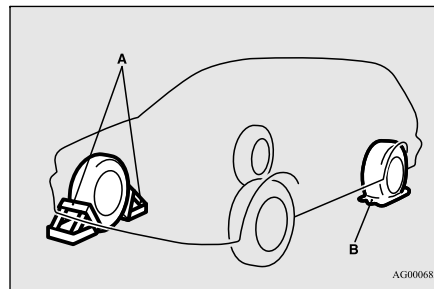

WARNING

- Be sure to apply chocks or blocks to the correct tyre when jacking up the vehicle. If the vehicle moves while jacked up, the jack could slip out of position, leading to an accident.

NOTE

- The chocks shown in the illustration do not come with your vehicle. It is recommended that you keep ones in the vehicle for use if needed.
- If chocks are not available, use stones or any other objects that are large enough to hold the wheel in position.

6. Get the jack bar and wheel nut wrench ready. Refer to “Tools and jack” on page 8-5.

Spare wheel information

E00803602114

The spare wheel is stored under the floor of the luggage area.

Check the air pressure of the spare tyre frequently and make sure it is ready for emergency use at any time.

Maintaining the spare wheel at the highest specified air pressure will ensure that it can always be used under any conditions

(city/high-speed driving, varying load weight, etc.).

⚠ CAUTION

- The pressure should be periodically checked and maintained at the specified pressure while the tyre is stowed. Driving with an insufficient tyre pressure can lead to an accident. If you have no choice but to drive with an insufficient tyre pressure, keep your speed down and inflate the tyre to the correct pressure as soon as possible. (Refer to “Tyre inflation pressures” on page 10-11.)

To remove the spare wheel

E00803501927

1. Open the tailgate and open the luggage floor board (A).

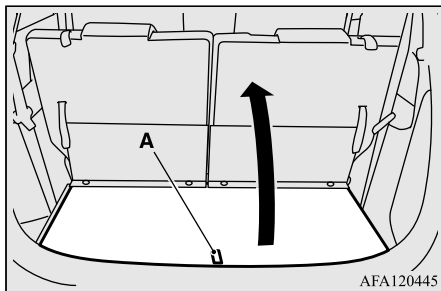

2. Remove the tyre hanger installation bolt cover (B).

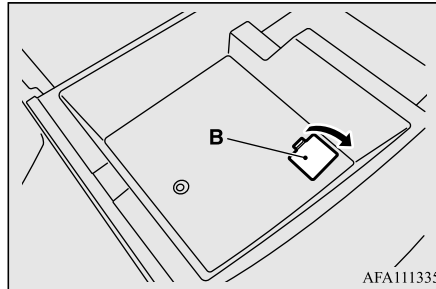

3. First, hold the wheel nut wrench as shown in the illustration (C) and loosen the tyre hanger installation bolt. Then, when it becomes easier to loosen the bolt, hold the wheel nut wrench as shown in the illustration (D) and continue to loosen the bolt.

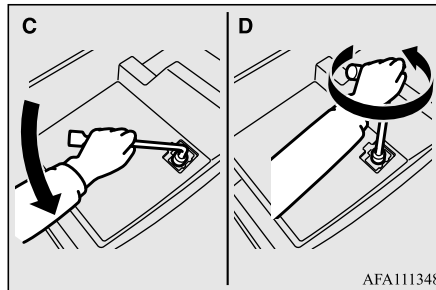

⚠ CAUTION

- Be careful as you loosen the tyre hanger installation bolt. If you loosen it too far, the hook may come out and let the spare wheel fall.

4. Lift up the tyre hanger (E) at the section indicated by the arrow in the diagram, remove it from the hook (F), lower it, and then take the tyre off the tyre hanger.

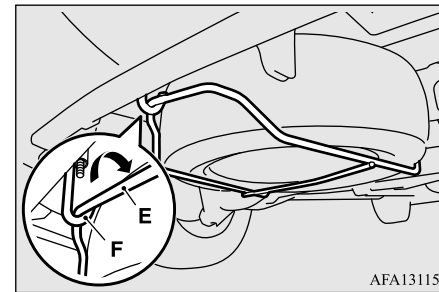

8

⚠ CAUTION

- When removing the tyre hanger from the hook or hanging it back on the hook, hold the tyre hanger carefully so that it does not drop on your feet.

How to change a tyre

NOTE

- Put the spare wheel under the vehicle body near the jack. This makes it safer if the jack slips out of position.

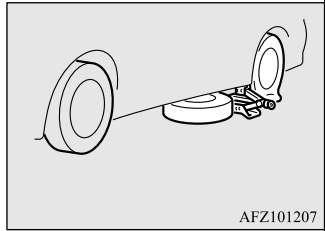

8

To change a tyre

E00803202905

1. Loosen the wheel nuts a quarter turn with the wheel nut wrench. Do not remove the wheel nuts yet.

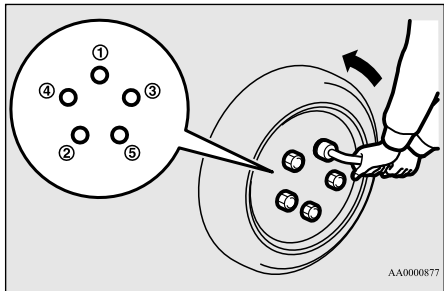

2. Place the jack under one of the jacking points (A) shown in the illustration. Use the jacking point closest to the tyre you wish to change.

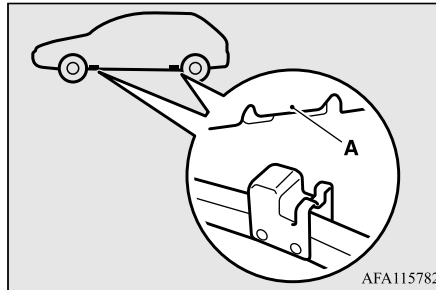

WARNING

- Set the jack only at the positions shown here. If the jack is set at a wrong position, it could dent your vehicle or the jack might fall over and cause personal injury.
- Do not use the jack on a tilted or soft surface. Otherwise, the jack might slip and cause personal injury. Always use the jack on a flat, hard surface. Before setting the jack, make sure there are no sand or pebbles under the jack base.

3. Rotate the jack by hand until the flange portion (B) fits in the groove (C) at the top of the jack.

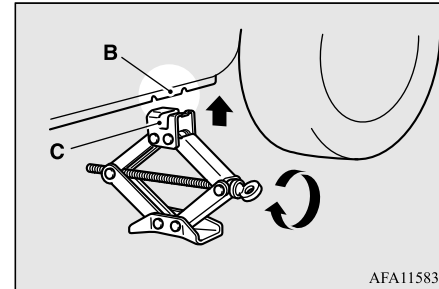

4. Insert the jack bar (D) into the wheel nut wrench (E). Then put the end of the jack bar into the shaft's jack end, as shown in the illustration. Slowly rotate the wheel nut wrench until the tyre is raised slightly off the ground surface.

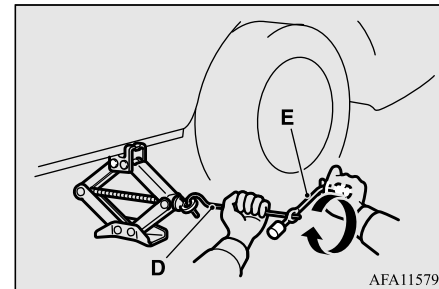

⚠ WARNING

- Stop jacking up the vehicle as soon as the tyre is raised off the ground. It is dangerous to raise the vehicle any higher.
- Do not get under your vehicle while using the jack.
- Do not bump the raised vehicle or leave it sitting on the jack for a long time. Both are very dangerous.
- Do not use a jack except the one that came with your vehicle.
- The jack should not be used for any purpose other than to change a tyre.
- No one should be in your vehicle when using the jack.
- Do not start or run the engine while your vehicle is on the jack.
- Do not turn the raised wheel. The tyres still on the ground could turn and make your vehicle fall off the jack.

5. Remove the wheel nuts with the wheel nut wrench, then take the wheel off.

⚠ CAUTION

- Handle the wheel carefully when changing the tyre, to avoid scratching the wheel surface.

6. Clean out any mud, etc. on the hub surface (F), hub bolts (G) or in the installation holes (H) in the wheel, and then mount the spare tyre.

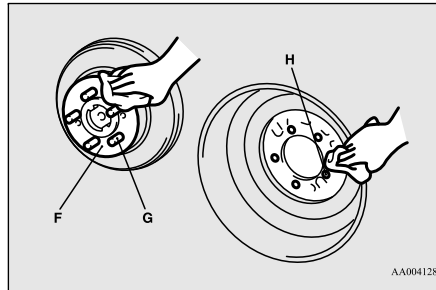

⚠ WARNING

- Mount the spare wheel with the valve stem (I) facing outboard. If you cannot see the valve stem (I), you have installed the wheel backwards. Operating the vehicle with the spare wheel installed backwards can cause vehicle damage and result in an accident.

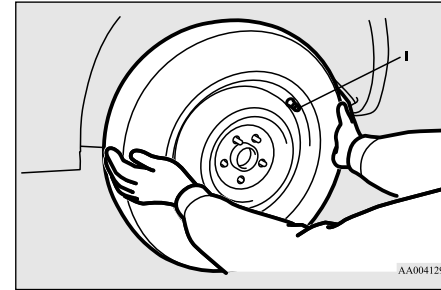

7. Finger-tighten the wheel nuts.

⚠ CAUTION

- Never apply oil to either the wheel bolts or the nuts or they will tighten too much.

Vehicle with the tapered nuts

- Tighten the wheel nuts until the tapered parts of the wheel nuts make light contact with the seats of the wheel holes and the wheel is not loose.

8

How to change a tyre

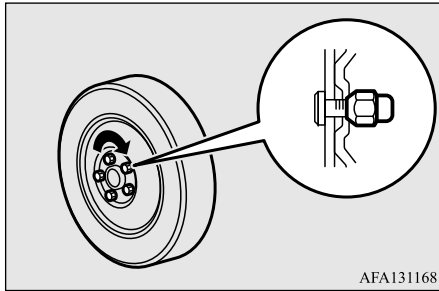

8

Vehicle with the flange nuts

- Tighten the wheel nuts until the flanges of the wheel nuts touch the wheel and the wheel is not loose.

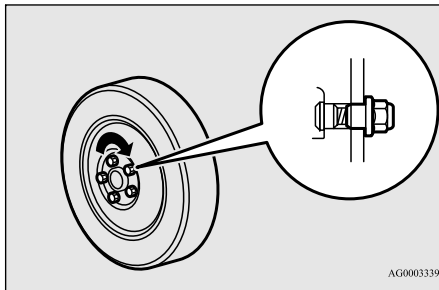

NOTE

- If all four aluminium wheels are changed to steel wheels, use tapered nuts.

8. Lower the vehicle slowly by rotating the wheel nut wrench anticlockwise until the tyre touches the ground.

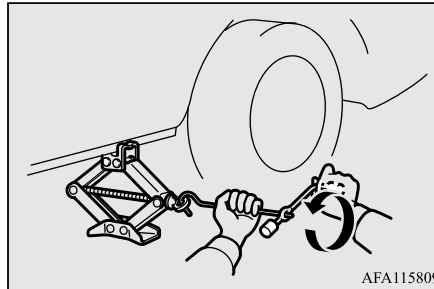

9. Tighten the nuts in the order shown in the illustration until each nut has been tightened to the torque listed here.

Tightening torque 88 to 108 N•m

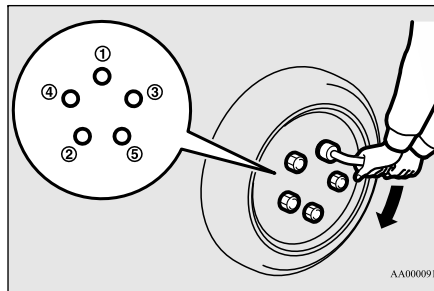

CAUTION

- Never use your foot or a pipe extension for extra force in the wheel nut wrench. If you do so, you will tighten the nut too much.

10. Lower and remove the jack, then store the jack, flat tyre, and chocks. Have your damaged tyre repaired as soon as possible.
11. Check your tyre inflation pressure at the next gas station. The correct tyre pressures are shown on the driver's door label. See the illustration.

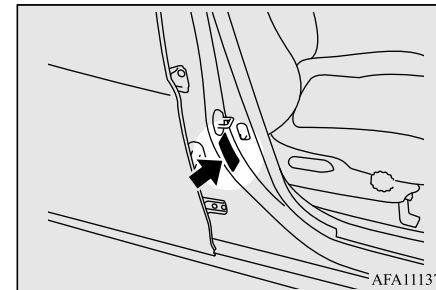

CAUTION

- After changing the tyre and driving the vehicle approximately 1000 km, retighten the wheel nuts to make sure that they have not come loose.

⚠ CAUTION

- If the steering wheel vibrates when driving after changing the tyre, we recommend you to have the tyres checked for balance.
- Do not mix one type of tyre with another or use a different size from the one listed. This would cause early wear and poor handling.

To store the spare wheel

E00803701802

1. Put the tyre on the centre of the tyre hanger, with the wheel surface facing upwards.

⚠ CAUTION

- Storing the tyre with the wheel surface facing down may damage the wheel or tyre hanger. If you find any damage on a spare tyre, do not use the tyre and contact an authorised MITSUBISHI MOTORS dealer.

2. Lift up the tyre hanger (A) and hang it on the hook (B).

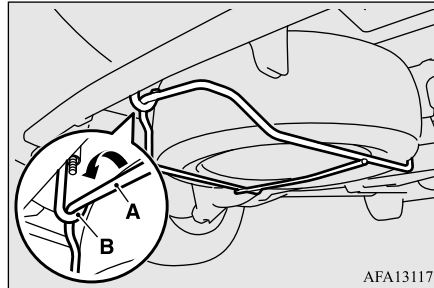

⚠ CAUTION

- Do not attach the hook to any part of the tyre hanger other than the correct position. Otherwise the hook could damage the vehicle body, or the tyre could fall while driving and cause an accident.

3. Open the tailgate.

First, hold the wheel nut wrench as shown in the illustration (C) and tighten the tyre hanger installation bolt. Then, hold the wheel nut wrench as shown in the illustration (D) and tighten the bolt securely.

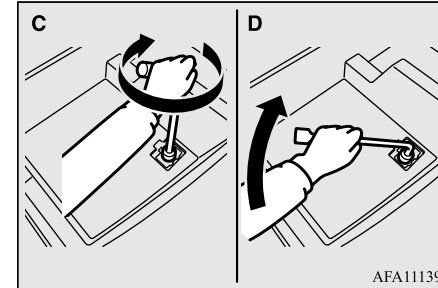

⚠ CAUTION

- After storing the spare wheel, check that the tyre hanger is securely locked in place. If the tyre hanger is not securely locked in place, it could come loose and fall while you are driving and cause an accident.
- When removing the tyre hanger from the hook or hanging it back on the hook, hold the tyre hanger carefully so that it does not drop on your feet.

4. Install the tyre hanger installation bolt cover.
5. Close the luggage floor board.

To store the tools and jack

E00803801278

Reverse the removing procedure when storing the jack, jack bar and wheel nut wrench. Refer to “Tools and jack” on page 8-5.

Towing

Towing

E00801506641

If your vehicle needs to be towed

If towing is necessary, we recommend you to have it done by your authorised MITSUBISHI MOTORS dealer or a commercial tow truck service.

8

In the following cases, transport the vehicle using a tow truck.

- The engine runs but the vehicle does not move, or an abnormal noise is produced.
- Inspection of the vehicle's underside reveals that oil or some other fluid is leaking.

If a wheel gets stuck in a ditch, do not try to tow the vehicle.

Please contact an authorised MITSUBISHI MOTORS dealer or a commercial tow truck service for assistance.

Only when you cannot receive a towing service from an authorised MITSUBISHI MOTORS dealer or commercial tow truck service, tow your vehicle carefully in accordance with the instructions given in "Emergency towing" in this part.

8-12 For emergencies

The regulations concerning towing may differ from country to country. It is recommended that you obey the regulations of the area where you are driving your vehicle.

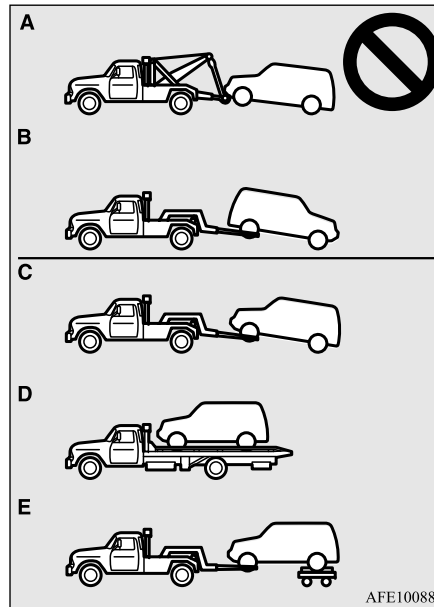

Towing the vehicle by a tow truck

⚠ CAUTION

- This vehicle must not be towed by a tow truck using sling lift type equipment (Type A) as illustrated. Using a sling lift will damage the bumper and front end.
- Do not tow the vehicle with the driving wheels on the ground (Type B) as illustrated. This could result in the driving system damage.
- If the transmission is malfunctioning or damaged, transport the vehicle with the driving wheels on a carriage (Type C, D or E) as illustrated.
- If the vehicle is towed with the operation mode in ON and only the front wheels raised off the ground (Type C), the ASC may operate, resulting in an accident. When towing the vehicle with the front wheels raised, keep the operation mode in ACC or OFF.

Towing with front wheels off the ground (Type C)

Release the parking brake.

Place the selector lever in the "N" (NEUTRAL) position.

Emergency towing

E00804201194

If towing service is not available in an emergency, your vehicle may be temporarily towed by a rope secured to the towing hook. In case of your vehicle is to be towed by another vehicle or your vehicle tows another vehicle, pay careful attention to the following points.

If your vehicle is to be towed by another vehicle

1. Take out the towing hook and jack bar. Refer to "Tools and jack" on page 8-5.
2. Cover the end of the jack bar (A) with cloth and use it to remove the lid from the front bumper.

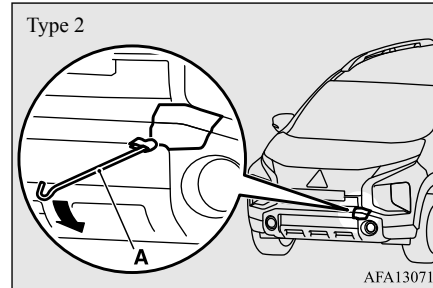
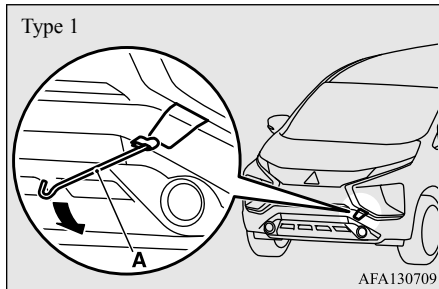

3. Use the jack bar to firmly attach the towing hook.

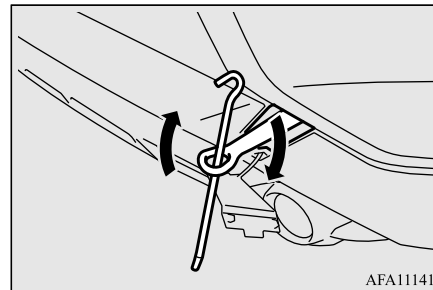

4. Secure the tow rope to the front towing hook.

NOTE

- Using any part other than the designated towing hook could result in damage to vehicle body.

NOTE

- Using a wire rope or metal chain can result in damage to the vehicle body. It is best to use a non-metallic rope. If you use a wire rope or metal chain, wrap it with cloth at any point where it touches the vehicle body.
- Use care that the tow rope is kept as horizontal as possible. An angled tow rope can damage the vehicle body.
- Secure the tow rope to the same side towing hook, to keep the tow rope as straight as possible.

5. Keep the engine running.

If the engine is not running, perform the following operation to unlock the steering wheel.

[Except for vehicles with the keyless operation system]

Turn the ignition switch to the "ON" position.

[For vehicles with the keyless operation system]

Put the operation mode in ON.

8

WARNING

- When the engine is not running, the brake booster and power steering system do not operate. This means higher brake depression force and higher steering effort are required. Therefore, vehicle operation is very difficult.

Towing

8

⚠ CAUTION

- Do not leave the ignition switch in the “LOCK” position or the operation mode in OFF. The steering wheel will lock, causing loss of control.

6. Place the selector lever in the “N” (NEUTRAL) position.
7. Turn on the hazard warning lamps if required by law. (Follow the local driving laws and regulations)
8. During towing make sure that close contact is maintained between the drivers of both vehicles, and that the vehicles travel at low speed.

⚠ WARNING

- Avoid sudden braking, acceleration and steering wheel movements; such driving operation could cause damage to the towing hook or towing rope. People in the vicinity could be injured as a result.
- When going down a long slope, the brakes may overheat, reducing effectiveness. Have your vehicle transported by a tow truck.

⚠ CAUTION

- The person in the vehicle being towed must pay attention to the brake lamps of the towing vehicle and make sure the rope never becomes slack.
- When a vehicle is to be towed by another vehicle with all wheels on the ground, make sure that the towing speed and distance given below are never exceeded, avoiding damage to the transmission.

Towing speed: 40 km/h
Towing distance: 40 km

For the towing speed and the towing distance, follow the local driving laws and regulations.

9. When finished towing, remove the towing hook, and stow it in the specified location. Refer to “Tools and jack” on page 8-5. When installing the bumper lid, align the hook with the cut out area on the vehicle, and firmly insert.

If your vehicle tows another vehicle

Remove the bumper lid on the rear bumper, and then install the towing hook (C) and use it for towing. The instructions are the same as

for “If your vehicle is to be towed by another vehicle”.

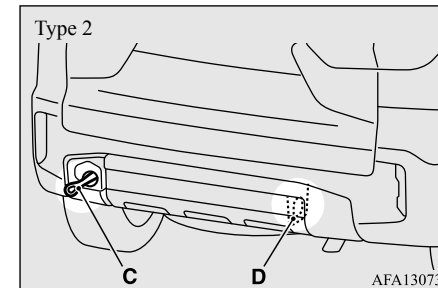
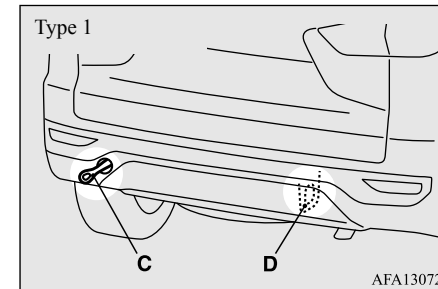

📖 NOTE

- Do not use the tie-down hook (D) for towing. This hook is provided only for the purpose of transporting the vehicle itself. Using any part other than the designated towing hook (C) could result in damage to vehicle body.

Operation under adverse driving conditions

NOTE

- Do not tow a vehicle heavier than your own vehicle.

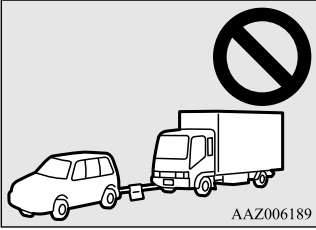

AAZ006189

Operation under adverse driving conditions

E00801704287

On a flooded road

- If water enters the brake discs, such as when driving through puddles, the brakes may temporarily become ineffective. In such cases, lightly depress the brake pedal to see if the brakes operate properly. If they do not, lightly depress the pedal several times while driving in order to dry the brake pads.
- When driving in rain or on a road with many puddles a layer of water may form between the tyres and the road surface.

This reduces a tyre's frictional resistance on the road, resulting in loss of steering stability and braking capability.

To cope with this, observe the following items:

- Drive your vehicle at a slow speed.
- Do not drive on worn tyres.
- Always maintain the specified tyre inflation pressures.

CAUTION

- Do not drive on flooded roads, through deep puddles, and so on. If you inevitably had to run on a flooded road and the vehicle was exposed to water, be sure to have your vehicle inspected by an authorised MITSUBISHI MOTORS dealer.

On a snow-covered or frozen road

- Avoid high-speed operation, sudden acceleration, abrupt brake application and sharp cornering.

CAUTION

- Do not press the accelerator pedal rapidly. If the wheels break free of the ice, the vehicle could suddenly start moving and possibly cause an accident.

On a bumpy or rutted road

Drive as slow as possible when driving on bumpy or rutted roads.

- Depressing the brake pedal during travel on snowy or icy roads may cause tyre slippage and skidding. When traction between the tyres and the road is reduced the wheels may skid and the vehicle cannot readily be brought to a stop by conventional braking techniques. Braking will differ, depending upon whether you have anti-lock brake system (ABS). As your vehicle is equipped with ABS, brake by pressing the brake pedal hard, and keeping it pressed.
- Allow extra distance between your vehicle and the vehicle in front of you, and avoid sudden braking.
- Accumulation of ice on the braking system can cause the wheels to lock. Pull away from a standstill slowly after confirming safety around the vehicle.

Operation under adverse driving conditions

CAUTION

- The impact on tyres and/or wheels when driving on a bumpy or rutted road can damage the tyre and/or wheel.

Vehicle care

Vehicle care precautions9-2
Cleaning the interior of your vehicle9-2
Cleaning the exterior of your vehicle9-3

Vehicle care precautions

Vehicle care precautions

E00900102034

In order to maintain the value of your vehicle, it is necessary to perform regular maintenance using the proper procedures.

Always maintain your vehicle in compliance with any environmental pollution control regulations.

Carefully select the materials used for washing, etc., to be sure that they do not contain corrosives.

If in doubt, we recommend you to consult a specialist for the selection of these materials.

9

CAUTION

- Cleaning products can be dangerous. Always follow the instructions of the cleaning product supplier.
- To avoid damage, never use the following to clean your vehicle.
 - Petrol
 - Paint Thinner
 - Benzine
 - Kerosene
 - Turpentine
 - Naphtha
 - Lacquer Thinner
 - Carbon Tetrachloride
 - Nail Polish Remover
 - Acetone

Cleaning the interior of your vehicle

E00900201878

After cleaning the interior of your vehicle with water, cleaner or similar, wipe and dry in a shady, well-ventilated area.

NOTE

- To clean the inside of the tailgate window, always use a soft cloth and wipe the window glass along the demister heater element so as not to cause damage.

CAUTION

- Do not use organic substances (solvents, benzine, kerosene, alcohol, petrol, etc.) or alkaline or acidic solutions. These chemicals can cause discolouring, staining or cracking of the surface. If you use cleaners or polishing agents, make sure their ingredients do not include the substances mentioned above.

Plastic, vinyl leather, fabric and flocked parts

E00900301619

1. Lightly wipe these off with a soft cloth soaked in a mild soap and water solution.

2. Dip cloth in fresh water and wring it out well. Using this cloth, wipe off the detergent thoroughly.

NOTE

- Do not use cleaners, conditioners, and protectants containing silicones or wax. Such products can cause discolouring and, when applied to the instrument panels or other parts, may cause reflections on the windscreen and obscure vision. Also, if such products get on the switches of the electrical accessories, it may lead to failure of these accessories.
- Do not use synthetic fiber or dry cloth. They can cause discolouring or damaging the surface.
- Do not place a deodorizer on the instrument panel or near lamps and instruments. The ingredients for deodorizer can cause discolouring or cracking.

Upholstery

E00900501233

1. To maintain the value of your new vehicle, handle the upholstery carefully and keep the interior clean.

Use a vacuum cleaner and brush to clean the seats. If stained, vinyl and synthetic leather should be cleaned with an appropriate cleaner. Cloth fabrics can be cleaned with either upholstery cleaner or a mild soap and water solution.

2. Clean the carpeting with a vacuum cleaner and remove any stains with carpet cleaner. Oil and grease can be removed by lightly dabbing with a clean colourfast cloth and stain remover.

Genuine leather*

E00900602042

1. To clean, lightly wipe the leather with a soft cloth soaked in a mild soap and water solution.
2. Dip cloth in fresh water and wring it out well. Using this cloth, wipe off the detergent thoroughly.
3. Apply leather protecting agent to the genuine leather surface.

NOTE

- If genuine leather is wet with water or is washed in water, wipe off water as quickly as possible with a dry, soft cloth. If left damp, mildew may grow.
- Organic solvents such as benzine, kerosene, alcohol and petrol, acid or alkaline solvents may discolour the genuine leather surface. Be sure to use neutral detergents.

NOTE

- Remove dirty patches or oil substances quickly as they can stain genuine leather.
- The genuine leather surface may harden and shrink if it is exposed to direct rays of the sun for long hours. When your vehicle is parked, place it in the shade as much as possible.
- When the temperature of the vehicle interior rises in summer, vinyl products left on the genuine leather seat may deteriorate and stick to the seat.

Cleaning the exterior of your vehicle

E00900701293

If the following is left on your vehicle, it may cause corrosion, discolouration and stains, wash the vehicle as soon as possible.

- Seawater, road deicing products.
- Soot and dust, iron powder from factories, chemical substance (acids, alkalis, coal-tar, etc.).
- Droppings from birds, carcasses of insects, tree sap, etc.

Washing

E00900904502

Chemicals contained in the dirt and dust picked up from the road surface can damage

Cleaning the exterior of your vehicle

the paint coat and body of your vehicle if left in prolonged contact.

Frequent washing and waxing is the best way to protect your vehicle from this damage. This will also be effective in protecting it from environmental elements such as rain, snow, salt air, etc.

Do not wash the vehicle in direct sunlight. Park the vehicle in the shade and spray it with water to remove dust. Next, using an ample amount of clean water and a car washing brush or sponge, wash the vehicle from top to bottom.

Use a mild car washing soap if necessary. Rinse thoroughly and wipe dry with a soft cloth. After washing the vehicle, carefully clean the joints and flanges of the doors, bonnet and other sections where dirt is likely to remain.

CAUTION

- When washing the under side of your vehicle or wheel, be careful not to injure your hands.
- Refrain from excessively using a car wash as its brushes may scratch the paint surface, causing it to lose its gloss. Scratches will be especially visible on darker coloured vehicles.

Cleaning the exterior of your vehicle

9

CAUTION

- Never spray or splash water on the electrical components in the engine compartment. Doing so could have an adverse effect on the engine startability. Exercise caution also when washing the underbody; be careful not to spray water into the engine compartment.
- Some types of hot water washing equipment apply high pressure and heat to the vehicle. They may cause heat distortion and damage to the vehicle resin parts and may result in flooding of the vehicle interior. Therefore;
 - Maintain a distance of approximately 70 cm or more between the vehicle body and the washing nozzle.
 - When washing around the door glass, hold the nozzle at a distance of more than 70 cm and at right angles to the glass surface.
- After washing the vehicle, drive the vehicle slowly while lightly depressing the brake pedal several times in order to dry out the brakes. Leaving the brakes wet could result in reduced braking performance. Also, there is a possibility that they could freeze up or become inoperative due to rust, rendering the vehicle unable to move.

CAUTION

- Using an automatic car wash, pay attention to the following items, referring to the owner's manual or consulting a car wash operator. If the following procedure is not followed, it could result in damage to your vehicle.
 - The outside rear-view mirrors are retracted.
 - The pole antenna is removed. For details, refer to "Antenna: To remove" on page 7-30.
 - The wiper arms are secured in place with tape.
 - If your vehicle is equipped with a roof rails, consult a car wash operator before using the car wash.

During cold weather

The salt and other chemicals spread on the roads in some areas in winter can have a harmful effect on the vehicle body. You should therefore wash the vehicle as often as possible in accordance with our care-instructions. It is recommended to have a preservative applied and the underfloor protection checked before and after the cold weather season.

After washing your vehicle, wipe off all water drops from the rubber parts around the doors to prevent the doors from freezing.

NOTE

- To prevent freezing of the weatherstripping on the doors, bonnet, etc., they should be treated with silicone spray.

Waxing

E00901002115

Waxing the vehicle will help prevent the adherence of dust and road chemicals to the paintwork. Apply a wax solution after washing the vehicle, or at least once every three months to assist displacing of water.

Do not wax your vehicle in direct sunlight. You should wax after the surfaces have cooled.

For information on how to use wax refer to the owner's manual of the wax.

CAUTION

- Waxes containing high abrasive compounds should not be used.

Polishing

E00901101236

The vehicle should only be polished if the paintwork has become stained or lost its lustre. Do not polish parts with a mat coating and the plastic bumpers. Doing so could cause stains or damage the finish.

Cleaning plastic parts

E00901301980

Use a sponge or chamois leather. If a car wax adheres on a grey or black rough surface of the bumper, moulding or lamps, the surface becomes white. In such a case, wipe it off using lukewarm water and soft cloth or chamois leather.

CAUTION

- Do not use a scrubbing brush or other hard tools as they may damage the plastic part surface.
- Do not bring the plastic parts into contact with petrol, light oil, brake fluids, engine oils, greases, paint thinners, and sulphuric acid (battery electrolyte) which may crack, stain or discolour the plastic parts. If they touch the plastic parts, wipe them off with soft cloth, chamois or the like and an aqueous solution of neutral detergent then immediately rinse the affected parts with water.

Chrome parts

E00901401268

In order to prevent spots and corrosion of chrome parts, wash with water, dry thoroughly, and apply a special protective coating. This should be done more frequently in winter.

Aluminium wheels*

E00901501780

1. Remove dirt using a sponge while sprinkling water on the wheels.
2. Use neutral detergent on any dirt that cannot be removed easily with water. Rinse off the neutral detergent after washing the wheels.
3. Dry the wheels thoroughly using a chamois leather or a soft cloth.

CAUTION

- Do not use a brush or other hard implement on the wheels. Doing so could scratch the wheels.
- Do not use any cleaner that contains an abrasive substance or is acidic or alkaline. Doing so could cause the coating on the wheels to peel or become discoloured or stained.
- Do not directly apply hot water using a steam cleaner or by any other means.
- Contact with seawater and road deicer can cause corrosion. Rinse off such substances as soon as possible.

Window glass

E00901601390

The window glass can normally be cleaned using only a sponge and water. Glass cleaner can be used to remove oil, grease, insect carcasses, etc. After washing

the glass, wipe it dry with a clean, dry, soft cloth. Never use a cloth that is used for cleaning a painted surface to clean a window. Wax from the painted surface could get on the glass and lower glass transparency and visibility.

NOTE

- To clean the inside of the rear window, always use a soft cloth and wipe the window glass along the demister heater element so as not to cause damage.

Wiper blades

E00901701229

Use a soft cloth and glass cleaner to remove grease, dead insects, etc., from the wiper blades. Replace the wiper blades when they no longer wipe properly. (Refer to page 10-13.)

Engine compartment

E00902101594

Clean the engine compartment at the beginning and end of winter. Pay particular attention to flanges, crevices and peripheral parts where dust containing road chemicals and other corrosive materials might collect.

Cleaning the exterior of your vehicle

If salt and other chemicals are used on the roads in your area, clean the engine compartment at least every three months.

Never spray or splash water on the electrical components in the engine compartment, as this may cause damage.

Do not bring the nearby parts, the plastic parts and so on into contact with sulphuric acid (battery electrolyte) which may crack, stain or discolour them.

If they are in contact, wipe off with soft cloth, chamois or the like and an aqueous solution of neutral detergent then immediately rinse the affected parts with plenty of water.

Maintenance

Service precautions	10-2
Catalytic converter	10-3
Bonnet	10-3
Engine oil	10-4
Engine coolant	10-5
Washer fluid	10-6
Brake fluid	10-7
Battery	10-8
Tyres	10-10
Wiper blade rubber replacement	10-13
General maintenance	10-14
Fusible links	10-15
Fuses	10-15
Replacement of lamp bulbs	10-19

Service precautions

Service precautions

E01000103097

Adequate care of your vehicle at regular intervals serves to preserve the value and appearance as long as possible.

Maintenance items as described in this owner's manual can be performed by the owner.

We recommend you to have the periodic inspection and maintenance performed by an authorised MITSUBISHI MOTORS dealer or another specialist.

In the event a malfunction or a problem is discovered, we recommend you to have it checked and repaired. This section contains information on inspection maintenance procedures that you can do yourself. Follow the instructions and cautions for each of the various procedures.

10



A- Cooling fan

B- Caution label
C- Resistor

WARNING

- When checking or servicing the inside of the engine compartment, make sure the engine is switched off and has had a chance to cool down.
- If it is necessary to do work in the engine compartment with the engine running, be especially careful that your clothing, hair, etc., does not become caught by the cooling fan, drive belts, or other moving parts.
- After performing the maintenance work, make sure that no tools or cloths are left behind in the engine compartment. If they are left behind, a fire or damage to the vehicle may occur.
- The cooling fan can turn on automatically even if the engine is not running. Turn the ignition switch to the "LOCK" position or put the operation mode in OFF to be safe while you work in the engine compartment.
- Because the resistor (C) may be hot even if the cooling fan has stopped, do not touch the resistor. Burns could result.
- Do not smoke, cause sparks or allow open flames around fuel or battery. The fumes are flammable.
- Be extremely cautious when working around the battery. It contains poisonous and corrosive sulphuric acid.

WARNING

- Do not get under your vehicle with just the body jack supporting it. Always use automotive jack stands.
- Improper handling of components and materials used in the vehicle can endanger your personal safety. We recommend you to consult a specialist for necessary information.

Check items of engine compartment are located as shown in the figure below.

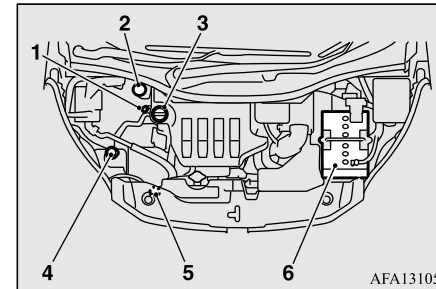

1. Engine oil level gauge
2. Brake fluid reservoir
3. Engine oil cap
4. Washer fluid reservoir
5. Engine coolant reservoir
6. Battery

Catalytic converter

E01000202730

The exhaust gas scavenging devices used with catalytic converter are extremely efficient for the reduction of noxious gases. The catalytic converter is installed in the exhaust system.

It is important to keep the engine properly tuned to ensure proper catalyst operation and prevent possible catalyst damage.

⚠ WARNING

- As with any vehicle, do not park or operate this vehicle in areas where combustible materials such as dry grass or leaves can come in contact with a hot exhaust since a fire could occur.
- Paint should not be applied to the catalytic converter.

📖 NOTE

- Use fuel of the type recommended in "Fuel selection" on page 2-2.

Bonnet

E01000304810

To open

1. Pull the release lever towards you to unlock the bonnet.

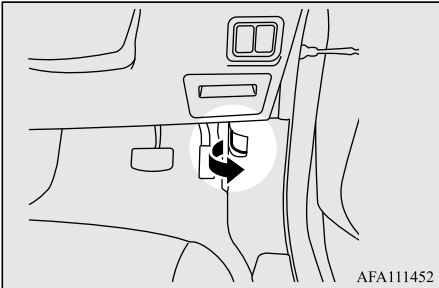

AFA111452

2. Raise the bonnet while pressing the safety lock.

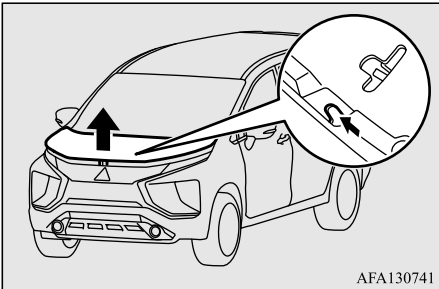

AFA130741

📖 NOTE

- Only open the bonnet when the wipers are in the original position. In any other position, the wipers could damage the paint or bonnet.

3. Support the bonnet by inserting the support bar in its slot.

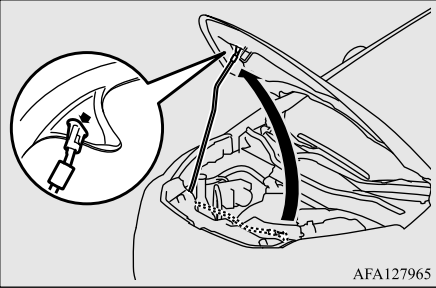

AFA127965

⚠ CAUTION

- Note that the support bar may disengage the bonnet if the open bonnet is lifted by a strong wind.
- After inserting the support bar into the slot, make sure the bar supports the bonnet securely from falling down on to your head or body.

Engine oil

To close

1. Unlatch the support bar and clip it in its holder.
2. Slowly lower the bonnet to a position approximately 20 cm above the closed position, then let it drop.
3. Make sure the bonnet is securely locked by softly lifting the centre of the bonnet.

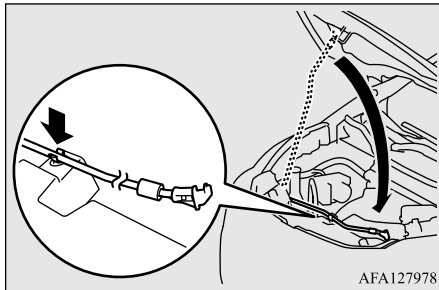

10

CAUTION

- Be careful that hands or fingers are not trapped when closing the bonnet.
- Before driving, make sure that the bonnet is securely locked. An incompletely locked bonnet can suddenly open while driving. This can be extremely dangerous.

NOTE

- If this does not close the bonnet, release it from a slightly higher position.
- Do not press down firmly on the bonnet as doing so could damage it.

Engine oil

E01000405498

To check and refill engine oil

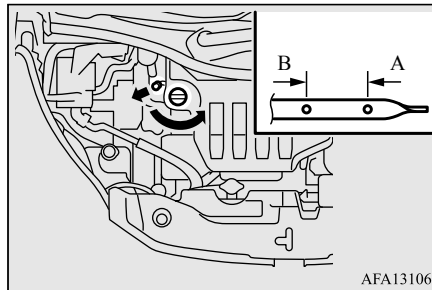

- A: Minimum level
B: Maximum level

The engine oil used has a significant effect on the engine's performance, service life and startability. Be sure to use oil of the recommended quality and appropriate viscosity. All engines consume a certain amount of oil during normal operation. Therefore, it is

important to check the oil level at regular intervals or before starting a long trip.

1. Park the vehicle on a horizontal surface.
2. Switch off the engine.
3. Wait a few minutes.
4. Remove the dipstick and wipe it with a clean cloth.
5. Reinsert the dipstick as far as it goes.
6. Remove the dipstick and confirm that the oil level is between the marks (A) and (B).
7. If the oil level is less than the level indicated by the mark (A), remove the cap and add enough oil to raise the level to between the marks (A) and (B).
8. After adding oil, close the cap securely.
9. Confirm the oil level by repeating step 4 to 6.

NOTE

- To avoid engine damage, do not overfill by exceeding the mark (B).
- Be sure to use the specified engine oil and do not mix various types of oil.
- When the oil level is checked in step 6 above, check it on a low side of the dipstick because it is different in appearance of oil level in the two sides of the dipstick.
- The engine oil will deteriorate rapidly if the vehicle is subjected to severe conditions, requiring earlier oil replacement. Please refer to the maintenance schedule.

NOTE

- For handling of used engine oils, refer to “Used engine oils safety instructions” on page 2-6.

Recommended engine oil viscosity

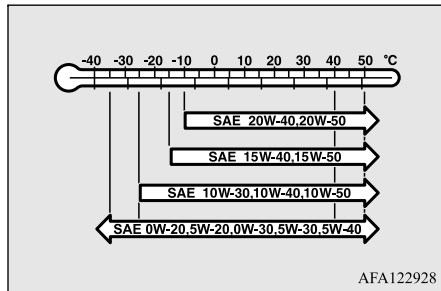

- Select engine oil of the proper SAE viscosity number according to the atmospheric temperature. SAE 0W-20, 5W-20, 0W-30, 5W-30, and 5W-40 engine oils can only be used if they meet ACEA A3/B3, A3/B4 or A5/B5 and API SG (or higher) specifications.
- Use engine oil conforming to the following classification:
 - API classification: “For service SG” or higher
 - ILSAC certificated oil

- ACEA classification: “For service A1/B1, A3/B3, A3/B4, or A5/B5”

NOTE

- Use of additives is not recommended since they may reduce the effectiveness of additives already included in the engine oil. It may result in failure of the mechanical assembly.
- If those classifications are not available, contact an authorised MITSUBISHI MOTORS dealer.

Engine coolant

E01000503727

To check the coolant level

A transparent coolant reserve tank (A) is located in the engine compartment. The coolant level in this tank should be kept between the “L” (LOW) and “F” (FULL) marks when measured while the engine is cold.

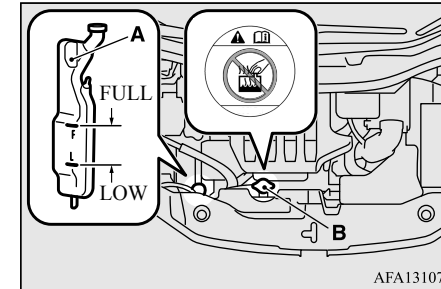

To add coolant

The cooling system is a closed system and normally the loss of coolant should be very slight. A noticeable drop in the coolant level could indicate leakage. If this occurs, have the system checked at an authorised MITSUBISHI MOTORS dealer as soon as possible.

If the level should drop below the “L” (LOW) level on the reserve tank, open the lid and add coolant.

Also, if the reserve tank is completely empty, remove the radiator cap (B) and add coolant until the level reaches the filler neck.

10

Washer fluid

⚠ WARNING

- Do not open the radiator cap (B) while the engine is hot. The coolant system is under pressure and any hot coolant escaping could cause severe burns.

Anti-freeze

The engine coolant contains an ethylene glycol anti-corrosion agent. Some parts of the engine are cast aluminium alloy, and periodic changing of the engine coolant is necessary to prevent corrosion of these parts.

10

Use “MITSUBISHI MOTORS GENUINE SUPER LONG LIFE COOLANT PRE-MIUM” or equivalent*.

*: similar high quality ethylene glycol based non-silicate, non-amine, non-nitrate and non-borate coolant with long life hybrid organic acid technology

MITSUBISHI MOTORS GENUINE Coolant has excellent protection against corrosion and rust formation of all metals including aluminium and can avoid blockages in the radiator, heater, cylinder head, engine block, etc.

Because of the necessity of this anti-corrosion agent, the coolant must not be replaced with plain water even in summer. The required

concentration of anti-freeze differs depending on the expected ambient temperature.

Above -35 °C: 50 % concentration of anti-freeze

Below -35 °C: 60 % concentration of anti-freeze

⚠ CAUTION

- Do not use alcohol or methanol anti-freeze or any engine coolants mixed with alcohol or methanol anti-freeze. The use of an improper anti-freeze can cause corrosion of the aluminium components.
- Do not use water to adjust the concentration of coolant.
- Concentrations exceeding 60 % will result in a reduction of both the anti-freeze and cooling performance thus adversely affecting the engine.
- Do not top up with water only.
Water by itself reduces the rust-protective and anti-freeze qualities of the coolant and has a lower boiling point. It can also cause damage to the cooling system if it should freeze. Do not use tap water, as it can cause corrosion and rust formation.

During cold weather

If the temperatures in your area drop below freezing, there is the danger that the coolant

in the engine or radiator could freeze and cause severe damage to the engine and/or radiator. Add a sufficient amount of anti-freeze to the coolant to prevent it from freezing.

The concentration should be checked before the start of cold weather and anti-freeze added to the system if necessary.

Washer fluid

E01000702517

Open the washer fluid reservoir cap and check the level of washer fluid.

If the level is low, replenish the container with washer fluid.

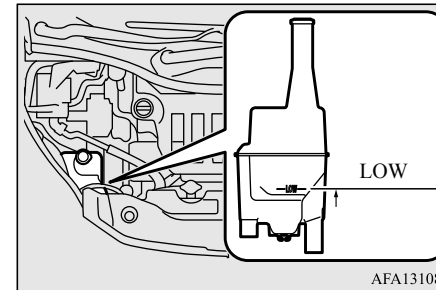

CAUTION

- Do not use any fluid other than water or washer fluid. Also, do not use soapy water, engine anti-freeze, or other liquid instead of washer fluid. Other liquids could cause streaking on the vehicle's painted surfaces, damage the washer pump, or clog the nozzle, leading to the washer fluid not spraying.

NOTE

- The washer fluid container serves the wind-screen and rear window.
- If the washer fluid level in the washer fluid reservoir is at the LOW mark, you can replenish with approximately 2 litres of washer fluid.

During cold weather

To ensure proper operation of the washers at low temperatures, use a fluid containing an anti-freezing agent.

Brake fluid

E01000802055

To check the fluid level

The fluid level must be between the "MAX" and "MIN" marks on the reservoir.

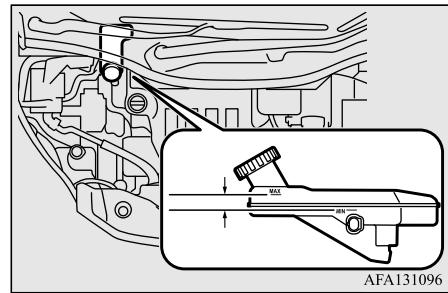

The fluid level is monitored by a float. When the fluid level falls below the "MIN" mark, the brake warning lamp lights up. The fluid level falls slightly with wear of the brake pads, but this does not indicate any abnormality.

The fluid in the master cylinder should be checked when doing other work under the bonnet. The brake system should also be checked for leaks at the same time.

If the fluid level falls markedly in a short length of time, it indicates leaks from the brake system.

If this occurs, we recommend you to have the vehicle checked.

Fluid type

Use brake fluid conforming to DOT3 or DOT4 from a sealed container. The brake fluid is hygroscopic. Too much moisture in the brake fluid will adversely affect the brake system, reducing the performance.

WARNING

- Take care in handling brake fluid as it is harmful to the eyes, may irritate your skin and will damage to painted surfaces. Wipe up spills immediately. If brake fluid gets on your hands or in your eyes, flush immediately with clean water. Follow up with a doctor as necessary.

CAUTION

- Use only the specified brake fluid. Do not mix or add different brand of brake fluid to prevent chemical reaction. Do not let any petroleum-based fluid touch, mix with, or get into the brake fluid. This will damage the seals.

Battery

⚠ CAUTION

- Keep the reservoir tank cap closed to prevent the brake fluid from deteriorating except maintenance.
- Make sure that the projection on the filler cap is pointing rearward as shown in the illustration when the cap is closed.

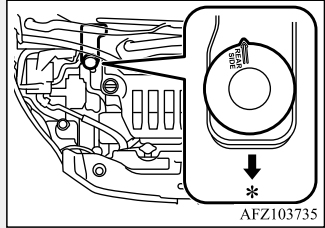

10

*: Front of the vehicle

- Clean the filler cap before removing and close the cap securely after maintenance.

Battery

E01001203981

The condition of the battery is very important for quick starting and to keep the vehicle's electrical system working properly. Regular inspection and care are especially important in cold weather.

📖 NOTE

- After replacing the battery, the electronic control system data for the automatic transmission, etc., will be erased. As a result, shift shocks may occur. Shift shocks will become smoother after several changes in speed.

Battery precautions

⚠ WARNING

- Note operating instructions



When you handle the battery, carefully observe the following cautions for safety.

- No smoking, no naked flames, no sparks



Keep sparks, cigarettes, and flames away from the battery because the battery could explode. Also, do not short-circuit the battery terminals. Doing so could create sparks.

⚠ WARNING

- Shield eyes



Always wear protective eye goggles when working near the battery. Battery electrolyte contains sulphuric acid, so getting it in your eyes is dangerous.

- Battery acid



Battery electrolyte contains sulphuric acid, so you must wear gloves and eye protection when handling the battery.

If battery electrolyte gets in your eyes or on your skin, rinse it away with clean water and immediately see a doctor.

If you accidentally swallow battery electrolyte, immediately see a doctor.

If battery electrolyte splashes on your clothing or on the vehicle, rinse it off with lots of water.

- Explosive gas



The battery emits highly explosive hydrogen gas. Ventilate when charging the battery in an enclosed space.

⚠ WARNING

- Keep away from children



Keep it out of reach of children.

Checking battery electrolyte level

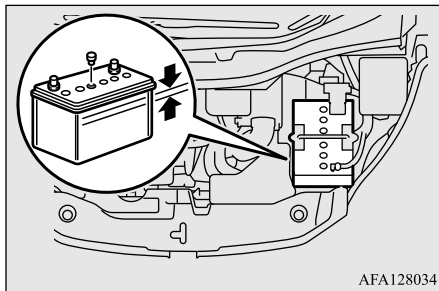

The electrolyte level must be between the specified limit on the outside of the battery. Replenish with distilled water as necessary. The inside of the battery is divided into several compartments; remove the cap from each compartment and fill to the upper mark. Do not top up beyond the upper mark because spillage during driving could cause damage.

Check the electrolyte level at least once every four weeks, depending on the operating conditions.

If the battery is not used, it will discharge by itself with time.

Check it once every four weeks and charge with low current as necessary.

During cold weather

The capacity of the battery is reduced at low temperatures. This is an inevitable result of its chemical and physical properties. This is why a very cold battery, particularly one that is not fully charged will only deliver a fraction of the starter current which is normally available.

We recommend you to have the battery checked before the start of cold weather and, if necessary, have it charged or replaced.

This does not only ensure reliable starting, but a battery which is kept fully charged also has a longer life.

Disconnection and connection

To disconnect the battery cable, stop the engine, first disconnect the negative (-) terminal and then the positive (+) terminal. When connecting the battery, first connect the posi-

tive (+) terminal and then the negative (-) terminal.

📖 NOTE

- Open the terminal cover (A) before disconnecting or connecting the positive (+) terminal of the battery.
- Loosen the nut (B), and then disconnect the battery cable from the positive (+) terminal.

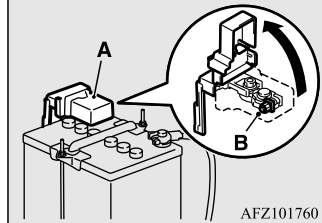

AFZ101760

10

⚠ WARNING

- Keep sparks, cigarettes, and flames away from the battery because the battery could explode.
- The battery electrolyte is extremely caustic. Do not allow it to come in contact with your eyes, skin, clothing, or the painted surfaces of the vehicle. Spilt electrolyte should be flushed immediately with ample amounts of water. Irritation to eyes or skin from contact with electrolyte requires immediate medical attention.

Tyres

WARNING

- **Ventilate when charging or using the battery in an enclosed space.**

CAUTION

- Keep it out of reach of children.
- Never disconnect the battery when the ignition switch is in the “ON” position or the operation mode in ON. Doing so could damage electric components.
- Never short-circuit the battery. This could cause it to overheat and be damaged.
- If the battery is to be quick-charged, first disconnect the battery cables.
- In order to prevent a short circuit, be sure to disconnect the negative (-) terminal first.
- Always wear protective eye goggles when working near the battery.
- Do not bring the nearby parts, the plastic parts and so on into contact with sulphuric acid (battery electrolyte) which may crack, stain or discolour them.

If they are in contact, wipe off with soft cloth, chamois or the like and an aqueous solution of neutral detergent then immediately rinse the affected parts with plenty of water.

NOTE

- Keep the terminals clean. After the battery is connected, apply terminal protection grease. To clean the terminals, use lukewarm water.
- Check to see if the battery is securely installed and cannot be moved during travel. Also check each terminal for tightness.
- When the vehicle is to be left unused for a long period of time, remove the battery and store it in a place where the battery fluid will not freeze. The battery should be stored only in a fully charged condition.

Tyres

E01001301526

WARNING

- **Driving with tyres that are worn, damaged or improperly inflated can lead to a loss of control or blow out of the tyres which can result in a collision with serious or fatal injury.**

Tyre inflation pressures

E01001404847

Tyre size	1–5 persons + cargo		6–7 persons + cargo	
	Front	Rear	Front	Rear
185/65R15 88H	2.3 bar (33 PSI) [230 kPa]	2.3 bar (33 PSI) [230 kPa]	2.3 bar (33 PSI) [230 kPa]	2.8 bar (41 PSI) [280 kPa]
205/55R16 91V	2.1 bar (30 PSI) [210 kPa]	2.1 bar (30 PSI) [210 kPa]	2.1 bar (30 PSI) [210 kPa]	2.6 bar (38 PSI) [260 kPa]
205/55R17 91V	2.1 bar (30 PSI) [210 kPa]	2.1 bar (30 PSI) [210 kPa]	2.1 bar (30 PSI) [210 kPa]	2.6 bar (38 PSI) [260 kPa]

Check the tyre inflation pressure of all the tyres while they are cold; if insufficient or excessive, adjust to the specified value. After the tyre inflation pressure has been adjusted, check the tyres for damage and air leaks. Be sure to put caps on the valves.

NOTE

- The tyres that can be installed on your vehicle are shown on the driver's door label. For details, contact an authorised MITSUBISHI MOTORS dealer.

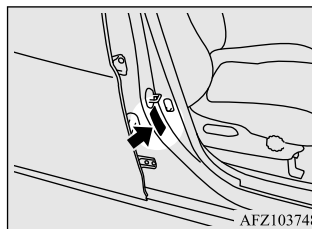

10

Wheel condition

E01001802140

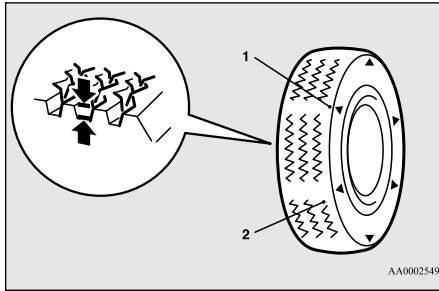

- 1- Location of the tread wear indicator
- 2- Tread wear indicator

10

Check the tyres for cuts, cracks and other damage. Replace the tyres if there are deep cuts or cracks. Also check each tyre for pieces of metal or pebbles.

The use of worn tyres can be very dangerous because of the greater chance of skidding or hydroplaning. The tread depth of the tyres must exceed 1.6 mm in order for the tyres to meet the minimum requirement for use.

Tread wear indicators will appear on the surface of the tyre as the tyre wears, thereby indicating that the tyre no longer meets the minimum requirement for use. When these wear indicators appear, the tyres must be replaced with new ones.

Replacing tyres and wheels

E01007201888

⚠ CAUTION

- Avoid using different size tyres from the one listed and the combined use of different types of tyres, as this can affect driving safety. Refer to “Tyres and wheels” on page 11-7.
- Even if a wheel has the same rim size and offset as the specified type of wheel, its shape may prevent it from being fitted correctly. We recommend you to consult a specialist before using wheels that you have.

Tyre rotation

E01001902763

Tyre wear varies with vehicle conditions, road surface conditions and individual driver’s driving habits. To equalise the wear and help extend tyre life, it is recommended to rotate the tyres immediately after discovery of abnormal wear, or whenever the wear difference between the front and rear tyres is recognisable.

When rotating tyres, check for uneven wear and damage. Abnormal wear is usually caused by incorrect tyre pressure, improper wheel alignment, out of balance wheel, or severe braking. Consult an authorised

MITSUBISHI MOTORS dealer to determine the cause of irregular tread wear.

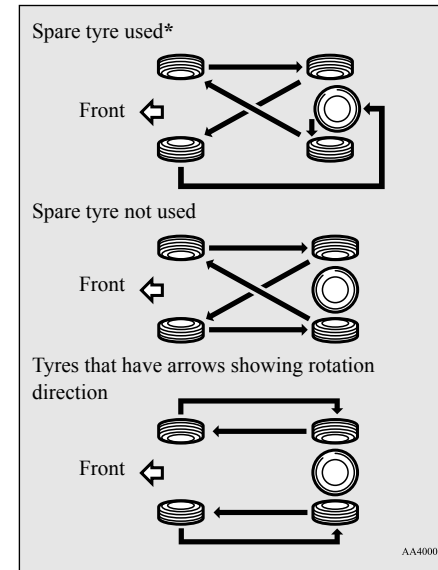

*: If the spare tyre wheel differs from the standard tyre wheel, do not perform tyre rotation using a spare wheel.

CAUTION

- If the tyres have arrows (A) indicating the correct direction of rotation, swap the front and rear tyres on the left-hand side of the vehicle and the front and rear tyres on the right-hand side of the vehicle separately. Keep each tyre on its original side of the vehicle. When fitting the tyres, make sure the arrows point in the direction in which the wheels will turn when the vehicle moves forward. Any tyre whose arrow points in the wrong direction will not perform to its full potential.

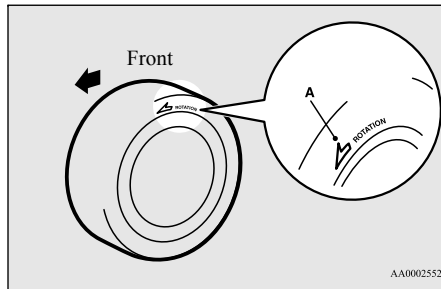

CAUTION

- Avoid the combined use of different types of tyres. Using different types of tyres can affect vehicle performance and safety.

Wiper blade rubber replacement

E01002601685

Windscreen wiper blades

1. Lift the wiper arm off the windscreen.
2. Pull the wiper blade until its stopper (A) disengages from the hook (B). Pull the wiper blade further to remove it.

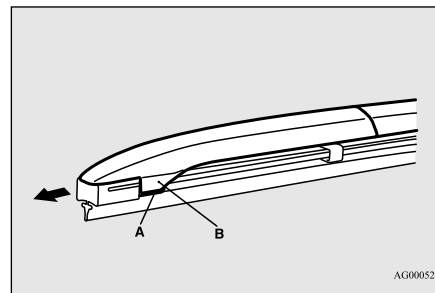

AG0005274

CAUTION

- Do not allow the wiper arm to fall onto the windscreen. This could damage the glass.

3. Attach the retainers (C) to a new wiper blade.

Refer to the illustration to ensure that the retainers are correctly aligned as you attach them.

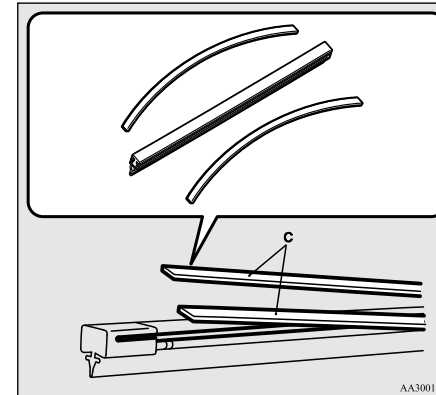

AA3001992

4. Insert the wiper blade into the arm, starting with the opposite end of the blade from the stopper. Make sure the hook (B) is fitted correctly in the grooves in the blade.

10

NOTE

- If retainers are not supplied with the new wiper blade, use the retainers from the old blade.

5. Push the wiper blade until the hook (B) engages securely with the stopper (A).

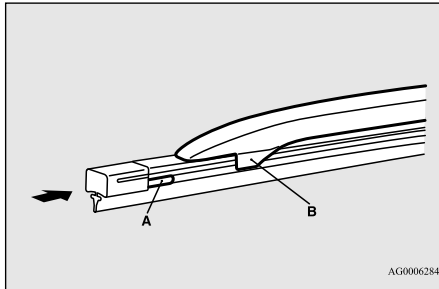

Rear window wiper blade

10

1. Lift the wiper arm off the window glass.
2. Pull the wiper blade downward to disengage it from the stopper (A) at the end of the wiper arm. Pull the wiper blade further to remove it.
3. Slide a new wiper blade through the hook (B) on the wiper arm.

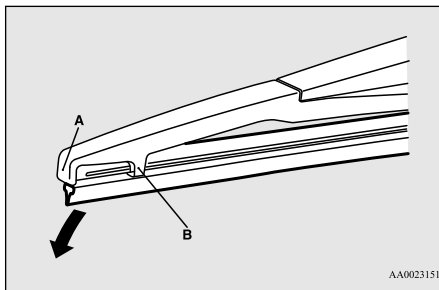

CAUTION

- Do not allow the wiper arm to fall onto the windows glass; it could damage the glass.

4. Firmly insert the retainer (C) into the groove (D) in the wiper blade. Refer to the illustration to ensure that the retainers are correctly aligned as you insert them into the groove.

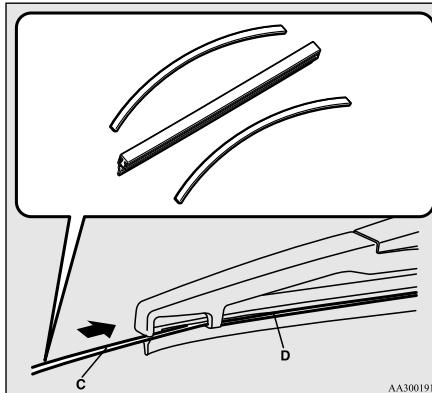

NOTE

- If a retainer is not supplied with the new wiper blade, use the retainer from the old blade.

General maintenance

E01002701703

Fuel, engine coolant, oil and exhaust gas leakage

Look under the body of your vehicle to check for fuel, engine coolant, oil and exhaust gas leaks.

WARNING

- If you see a suspicious fuel leak or if you smell fuel, do not operate the vehicle; call authorised MITSUBISHI MOTORS dealer for assistance.

Exterior and interior lamp operation

Operate the combination lamp switch to check that all lamps are functioning properly. If the lamps do not illuminate, the probable cause is a blown fuse or defective lamp bulb. Check the fuses first. If there is no blown fuse, check the lamp bulbs. For information regarding the inspection and replacement of the fuses and the bulbs, refer to “Fuses” on page 10-15 and “Replacement of lamp bulbs” on page 10-19.

If the fuses and bulbs are all OK, we recommend you to have your vehicle checked and repaired.

Meter, gauge and indicator/warning lamps operation

Start the engine and check the operation of all instruments, gauges and indicator and warning lamps.

If there is anything wrong, we recommend you to have your vehicle inspected.

Hinges and latches lubrication

Check all latches and hinges, and, if necessary, have them lubricated.

Fusible links

E01002901792

The fusible links will melt to prevent a fire if a large current attempts to flow through certain electrical systems.

In case of a melted fusible link, we recommend you to have your vehicle inspected.

For the fusible links, please refer to “Passenger compartment fuse location table” on page 10-16 and “Engine compartment fuse location table” on page 10-17.

WARNING

- Fusible links must not be replaced by any other device. Failing to fit the correct fusible link may result in fire in the vehicle, property destruction and serious or fatal injuries at any time.

Fuses

E01003003677

Fuse block location

To prevent damage to the electrical system due to short-circuiting or overloading, each individual circuit is provided with a fuse. There are fuse blocks in the passenger compartment and in the engine compartment.

Passenger compartment

The fuse block in the passenger compartment is located behind the glove box at the position shown in the illustration.

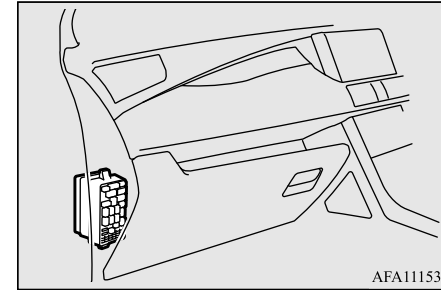

1. Open the glove box.
2. Pull the glove box fastener (A), then the fastener (B), in the directions of the arrows shown in the illustration to remove them.

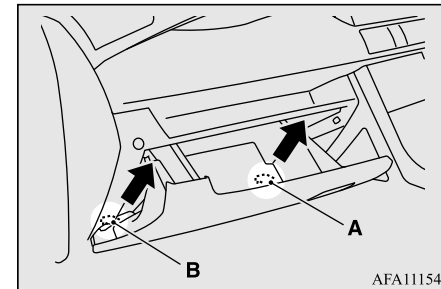

3. Slide the glove box at an angle to unhook the hook (C) on each side, and then pull out the glove box to remove it.

10

Fuses

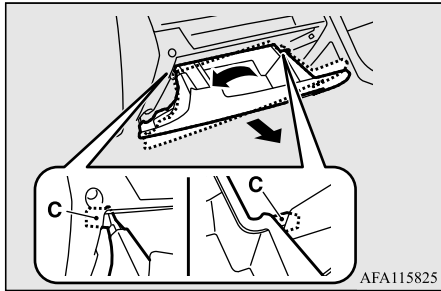

AFA115825

Engine compartment

In the engine compartment, the fuse block is located as shown in the illustration.

10

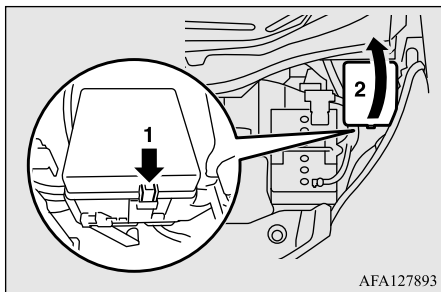

AFA127893

- 1- Press the tab.
- 2- Remove the cover.

Fuse load capacity

E01007702138

The fuse capacity and the names of electrical systems protected by the fuses are indicated on the back of the glove box and inside of the fuse block cover (inside of the engine compartment).

NOTE

- Spare fuses are provided in the fuse block of the engine compartment. Always use a fuse of the same capacity for replacement.

Passenger compartment fuse location table

E01007902244

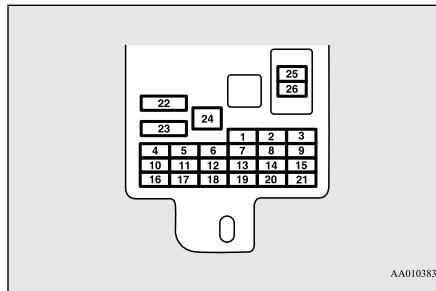

AA0103837

No.	Sym- bol	Electrical system	Capac- ities
1		Tail lamp (left)	7.5 A
2		Cigarette lighter	15 A
3		Ignition coil	10 A
4		Starter motor	7.5 A
5	—	—	—
6		Accessory socket	15 A
7		Tail lamp (right)	7.5 A
8		Outside rear-view mirrors	7.5 A
9		Engine control unit	7.5 A
10		Control unit	7.5 A
11		Rear fog lamp	10 A
12		Central door lock	15 A
13		Room lamp	15 A
14		Rear window wiper	15 A
15		Gauge	7.5 A
16		Relay	7.5 A
17		Rear cooler	10 A
18		Option	10 A
19		Demister switch Illumination	7.5 A

No.	Symbol	Electrical system	Capacities
20		Windscreen wiper	25 A
21		Reversing lamps	7.5 A
22		Demister	30 A
23		Heater	30 A
24	—	—	—
25		Radio	10 A
26		Electronic controlled unit	20 A

- Some fuses may not be installed on your vehicle, depending on the vehicle model or specifications.
- The table above shows the main equipment corresponding to each fuse.

Engine compartment fuse location table

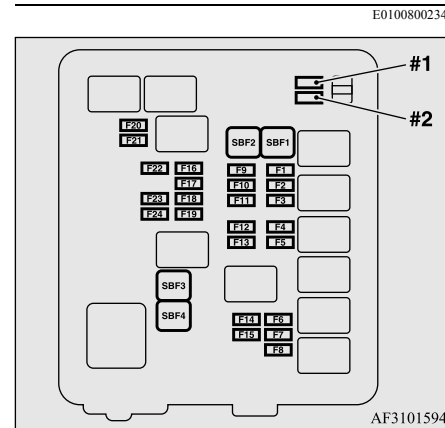





No.	Symbol	Electrical system	Capacity
SBF 1		Ignition switch	40 A*
SBF 2		Electric window control	30 A*
SBF 3		Anti-lock braking system	30 A*
SBF 4		Anti-lock braking system	40 A*
F1	—	—	—

No.	Symbol	Electrical system	Capacity
F2		Hazard warning flasher	10 A
F3		Starter	7.5 A
F4		Automatic transmission	15 A
F5	—	—	—
F6	—	—	—
F7	—	—	—
F8	—	—	—
F9		Alternator	7.5 A
F10		ETV	15 A
F11		Air conditioning	10 A
F12		Engine control	7.5 A
F13		Stop lamps (Brake lamps)	10 A
F14		Fuel pump	15 A
F15		ENG/POWER	15 A
F16	—	—	—
F17		Fog lamps	15 A
F18		Daytime running lamps	10 A

10

Fuses

10

No.	Symbol	Electrical system	Capacity
F19		Horn	10 A
F20		Headlamp low beam (right)	10 A
F21		Headlamp low beam (left)	10 A
F22	—	—	—
F23		Headlamp high beam (right)	10 A
F24		Headlamp high beam (left)	10 A
#1	—	Spare fuse	25 A
#2	—	Spare fuse	20 A

*: Fusible link

- Some fuses may not be installed on your vehicle, depending on the vehicle model or specifications.
- The table above shows the main equipment corresponding to each fuse.

The fuse block does not contain spare 7.5 A, 10 A, 15 A or 30 A fuses. If one of these fuses burns out, substitute with the following fuse.

7.5 A: Outside rear-view mirrors

10-18 Maintenance

10 A: Option

15 A: Cigarette lighter

30 A: Demister

When using a substitute fuse, replace with a fuse of the correct capacity as soon as possible.

Identification of fuse

E01008101477

Capacity	Colour
7.5 A	Brown
10 A	Red
15 A	Blue
20 A	Yellow
25 A	Natural (White)
30 A	Green (fuse type) /Pink (fusible link type)
40 A	Green (fusible link type)

Fuse replacement

E01007802054

1. Before replacing a fuse, always turn off the electrical circuit concerned and place the ignition switch in the "LOCK" position or put the operation mode in OFF.
2. Remove the fuse puller (A) from the inside of the fuse block in the engine compartment.

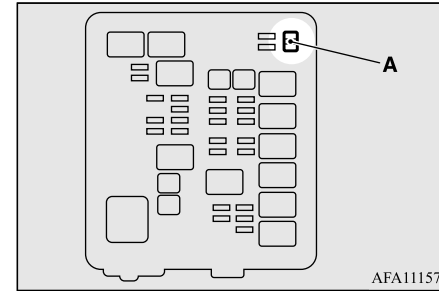

3. Referring to the fuse load capacity table, check the fuse pertaining to the problem.

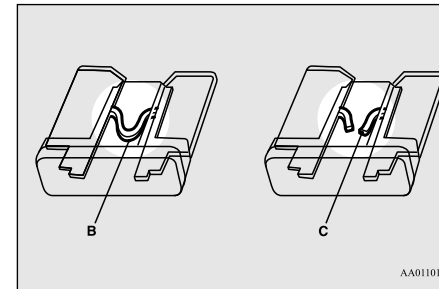

- B- Fuse is OK
C- Blown fuse

NOTE

- If any system does not function but the fuse corresponding to that system is normal, there may be a fault in the system elsewhere. We recommend you to have your vehicle checked.

4. Insert a new fuse of the same capacity by using the fuse puller into the same place the fuse block.

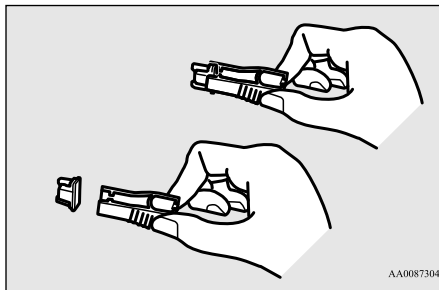

CAUTION

- If the newly inserted fuse blows again after a short time, we recommend you to have the electrical system checked to find the cause and rectify it.
- Never use a fuse with a larger capacity than specified or a substitute (such as a cable or foil). Doing so could cause the circuit wires to overheat and create a fire.

Replacement of lamp bulbs

E01003102264

Before replacing a bulb, ensure the lamp is off. Do not touch the glass part of the new bulb with your bare fingers; the skin oil left on the glass will evaporate when the bulb gets hot and the vapour will condense on the reflector and dim the surface.

CAUTION

- Do not install commercially available LED-type bulbs. Commercially available LED-type bulbs could adversely affect the operation of the vehicle, such as by preventing the lamps and other vehicle equipment from operating properly.
- Bulbs are extremely hot immediately after being turned off. When replacing a bulb, wait for it to cool sufficiently before touching it. You could otherwise be burnt.
- Handle halogen lamp bulb with care. The gas inside a halogen lamp bulb is highly pressurized, so dropping, knocking, or scratching a halogen lamp bulb can cause it to shatter.

CAUTION

- Never hold the halogen lamp bulb with a bare hand, dirty glove, etc. The oil from your hand could cause the bulb to break the next time the headlamps are operated. If the glass surface is dirty, it must be cleaned with alcohol, paint thinner, etc., and refit it after drying thoroughly.

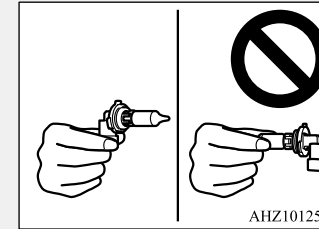

10

NOTE

- If you are unsure of how to carry out the work as required, we recommend you to consult a specialist.
- Be careful not to scratch the vehicle body when removing a lamp or lens.

Replacement of lamp bulbs

NOTE

- When it rains, or when the vehicle has been washed, the inside of the lens sometimes becomes foggy. This is the same phenomenon as when window glass mists up on a humid day, and does not indicate a functional problem.

When the lamp is switched on, the heat will remove the fog. However, if water gathers inside the lamp, we recommend you to have the lamp checked.

Bulb location and capacity

E01003201659

CAUTION

- When replacing a bulb, be sure to use a new bulb of the same type, wattage, and colour. If you install a different bulb, the bulb could malfunction or fail to come on and could lead to a vehicle fire.

10

Outside

E01003305919

Except for vehicles equipped with wheel lip moldings

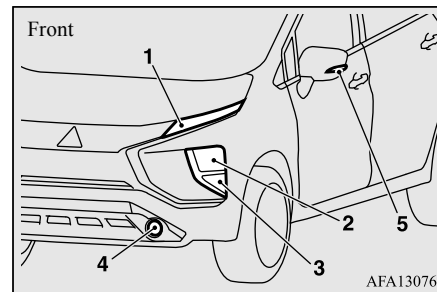

- 1- Position lamps: –
- 2- Headlamps: 60/55 W (H4)
- 3- Front turn-signal lamps: 21 W (PY21W)
- 4- Front fog lamps*: 19 W (H16)
- 5- Side turn-signal lamps: –

Vehicles equipped with wheel lip moldings

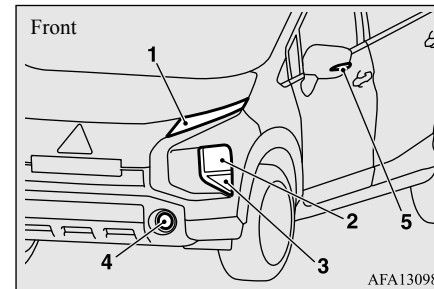

- 1- Position lamps: –
- 2- Headlamps: –
- 3- Front turn-signal lamps: 21 W (PY21W)
- 4- Front fog lamps: –
- 5- Side turn-signal lamps: –

Codes in parentheses indicate bulb types.

NOTE

- The following lamps use an LED instead of a bulb. If you need to repair or replace these lamps, contact an authorised MITSUBISHI MOTORS dealer.
 - Position lamps
 - Headlamps (LED type)
 - Front fog lamps (LED type)

NOTE

- Side turn-signal lamps

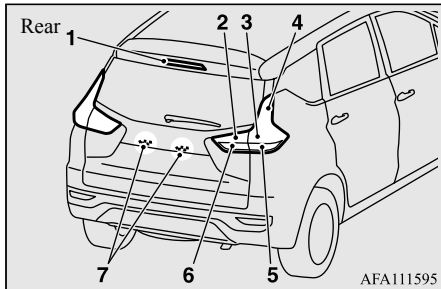

- 1- High mounted stop lamp: –
- 2- Tail lamps: –
- 3- Stop lamps: 21 W (W21W)
- 4- Tail lamps: –
- 5- Rear turn-signal lamps:
21 W (WY21W)
- 6- Reversing lamps: –
- 7- Licence plate lamps: 5 W (W5W)

Codes in parentheses indicate bulb types.

NOTE

- The following lamps use an LED instead of a bulb.
If you need to repair or replace these lamps, contact an authorised MITSUBISHI MOTORS dealer.
- High mounted stop lamp

NOTE

- Tail lamps
- Reversing lamps

Inside

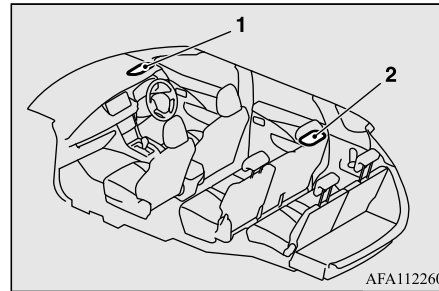

- 1- Room lamp (front): 8 W
- 2- Room lamp (rear): 8 W

Headlamps (halogen bulb)

E01009301740

1. Pull out the connector (A).

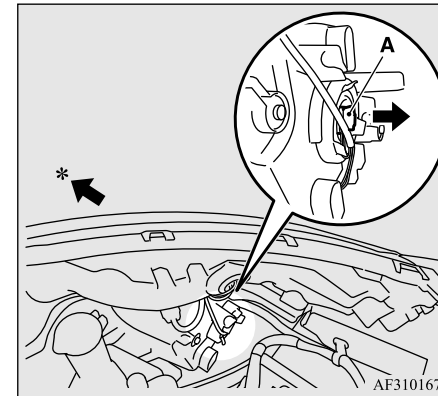

*: Front of the vehicle

2. Remove the sealing cover (B).

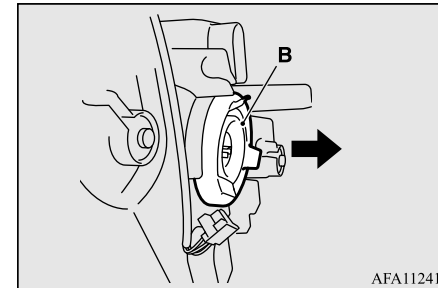

10

Replacement of lamp bulbs

- Unhook the spring (C), which secures the bulb, and then remove the bulb (D).

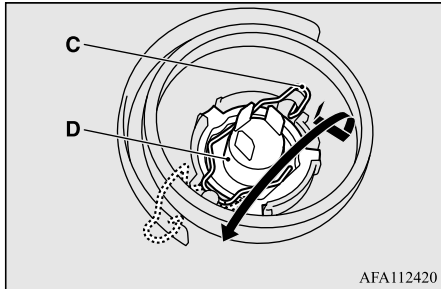

- To install the bulb, perform the removal steps in reverse.

10

NOTE

- When installing the sealing cover (B), make sure that the side of the cover with the arrow is facing up.

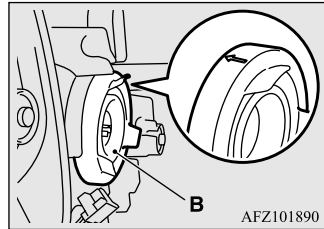

Front turn-signal lamps

E01003802607

- To create enough work space, turn the steering wheel all the way in the direction opposite to the side you wish to replace.
- Remove the bolts (A), and then remove the cover (B).

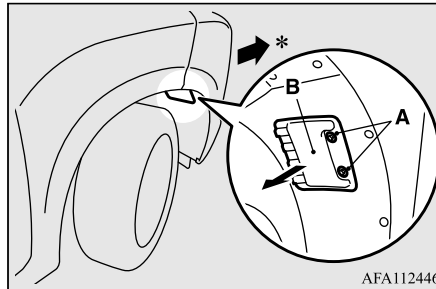

*: Front of the vehicle

- Turn the socket (C) anticlockwise to remove it.

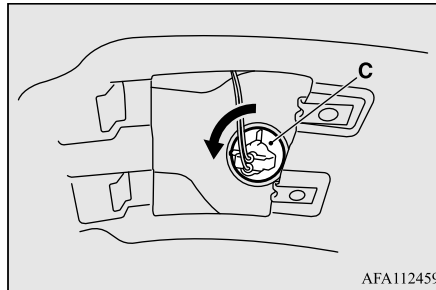

- Remove the bulb from the socket by turning it anticlockwise while pressing in.

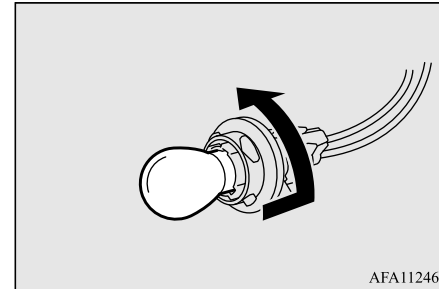

- To install the bulb, perform the removal steps in reverse.

NOTE

- When installing the cover, fit the projections (D) into the opening, and then tighten the bolts.

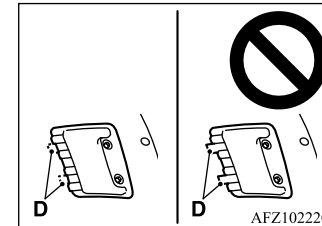

Front fog lamps (halogen bulb)*

E01004003906

1. Remove the bolt (A) on the bottom of the front bumper.

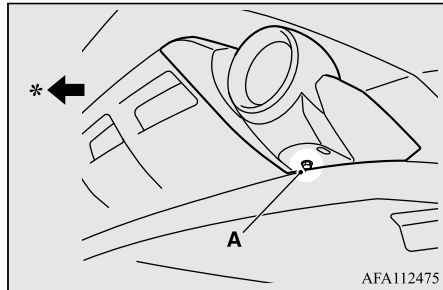

*: Front of the vehicle

2. Insert your hand in the bottom of the cover (B), release the 7 hooks indicated by the arrows in the illustration, and remove the cover.

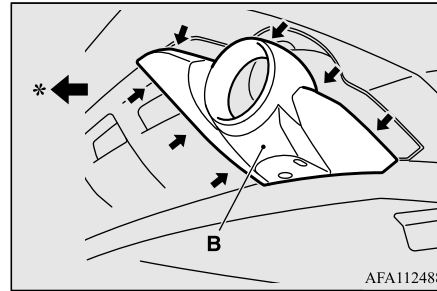

*: Front of the vehicle

3. Remove the 3 screws (C) and remove the lamp unit.

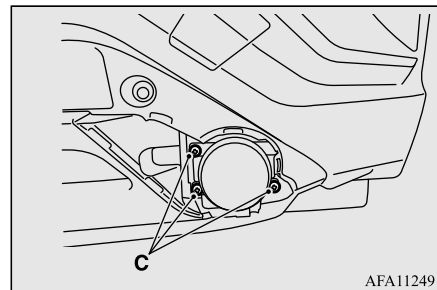

4. While holding down the tab (D), pull out the socket (E).

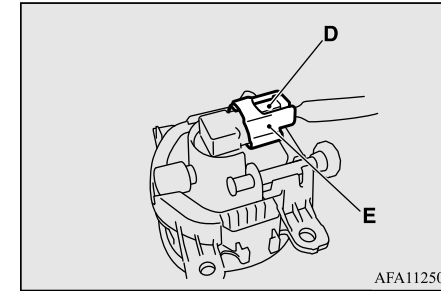

5. Turn the bulb (F) anticlockwise to remove it.

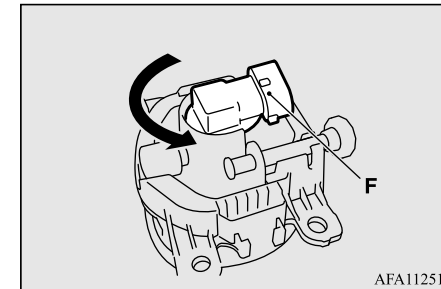

6. To install the bulb, perform the removal steps in reverse.

10

Rear combination lamps

E01004203012

1. Open the tailgate.

Replacement of lamp bulbs

- Remove the screws (A), and then move the lamp unit towards the rear of the vehicle to unfix the notch (B) and pins (C) of the lamp unit.

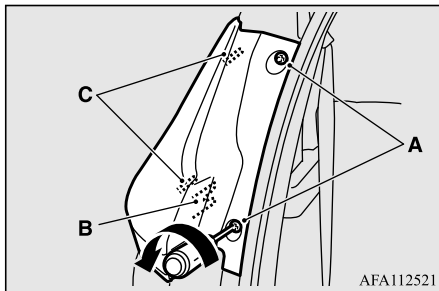

10

- When replacing the stop lamp bulb, remove the harness (D) from its holder.

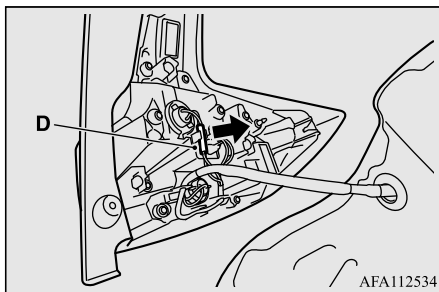

- Turn the socket anticlockwise and remove it, and then pull the bulb out of the socket.

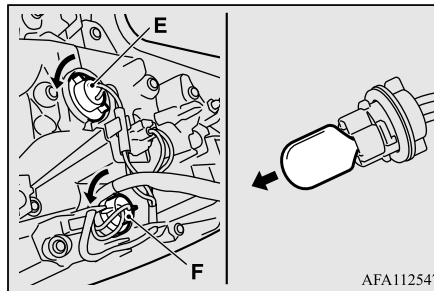

- E- Stop lamp
F- Rear turn-signal lamp

- To install the bulb, perform the removal steps in reverse.

NOTE

- When installing the lamp unit, fit the clip (G) on the body into the notch (H) in the lamp unit, and then push the entire lamp unit straight into the body.

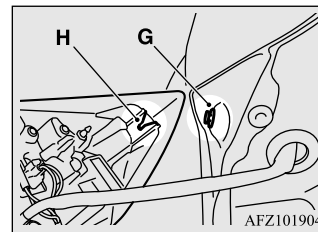

Licence plate lamps

E01004602370

- Remove while pressing the lamp unit (A) to the left side of the vehicle.

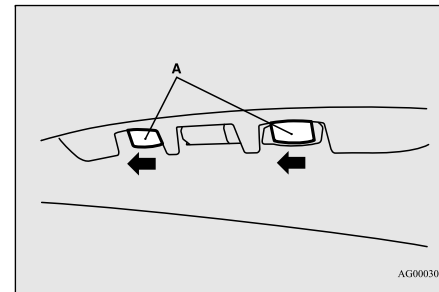

- Insert a minus screwdriver with the end covered with a cloth or other object to press the hook (B) aside and remove the lens.

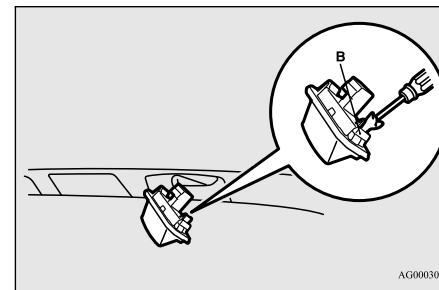

- Remove the bulb from the socket.

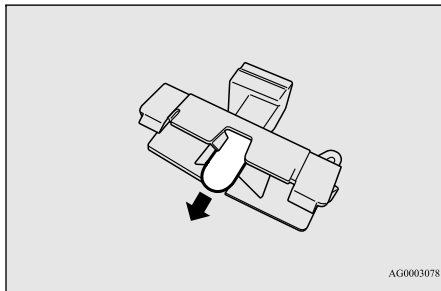

4. To install the bulb, perform the removal steps in reverse.

NOTE

- When installing the lamp unit, first insert the end of tab (C) and then align tab (D).

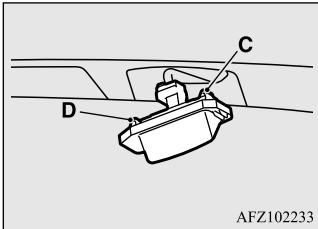

AFZ102233



Specifications

Vehicle labelling	11-2
Vehicle dimensions	11-3
Vehicle performance	11-6
Engine specifications	11-7
Electrical system	11-7
Tyres and wheels	11-7
Capacity	11-8

Vehicle labelling

Vehicle labelling

E01100105946

Vehicle identification number

The vehicle identification number is stamped on the floor under the right side of the front seat. It is visible by pulling back the carpet flap as shown in the illustration.

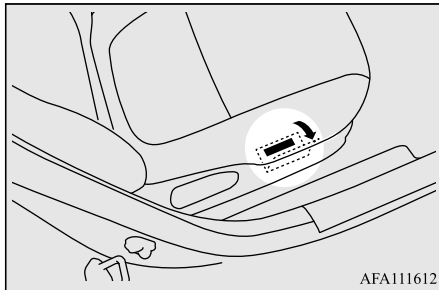

11

AFA111612

Engine model/number

The engine model and number are stamped on the engine cylinder block as shown in the illustration.

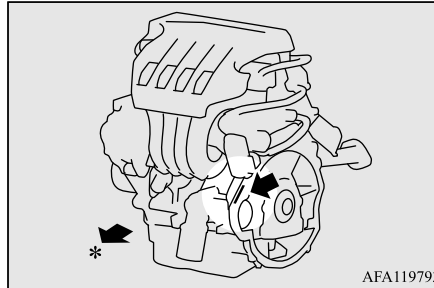

AFA119793

*: Front of the vehicle

Vehicle dimensions

E01100205530

Except for vehicles equipped with wheel lip moldings

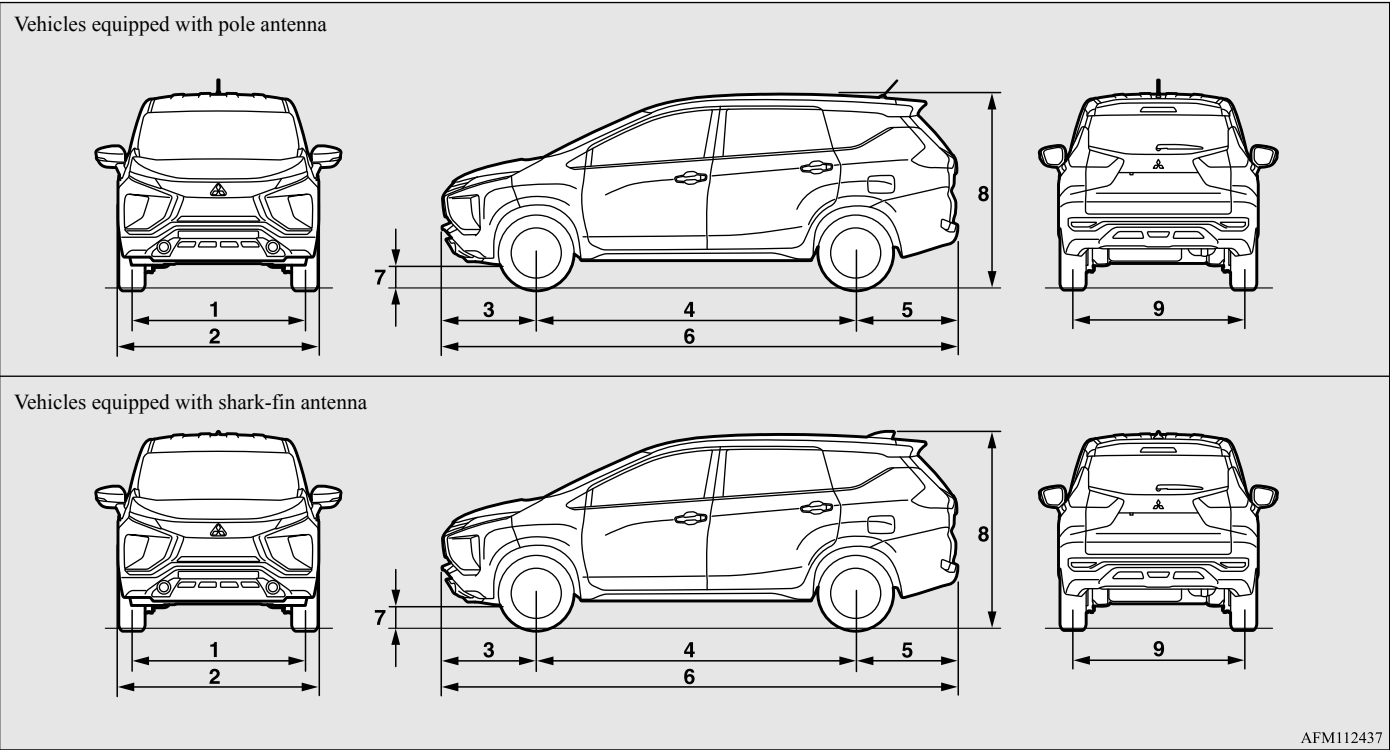

AFM112437

Vehicle dimensions

1	Front track		1,520 mm
2	Overall width		1,750 mm
3	Front overhang		820 mm
4	Wheel base		2,775 mm
5	Rear overhang		880 mm
6	Overall length		4,475 mm
7	Ground clearance (unladen)		200 mm ^{*1} , 205 mm ^{*2}
8	Overall height (unladen)	With pole antenna	1,695 mm ^{*1} , 1,700 mm ^{*2}
		With shark-fin antenna	1,725 mm ^{*1} , 1,730 mm ^{*2}
9	Rear track		1,510 mm
Minimum turning radius		Body	5.5 m
		Wheel	5.2 m

11

*¹: Vehicles equipped with 15 inch tyres

*²: Vehicles equipped with 16 inch tyres

Vehicles equipped with wheel lip moldings

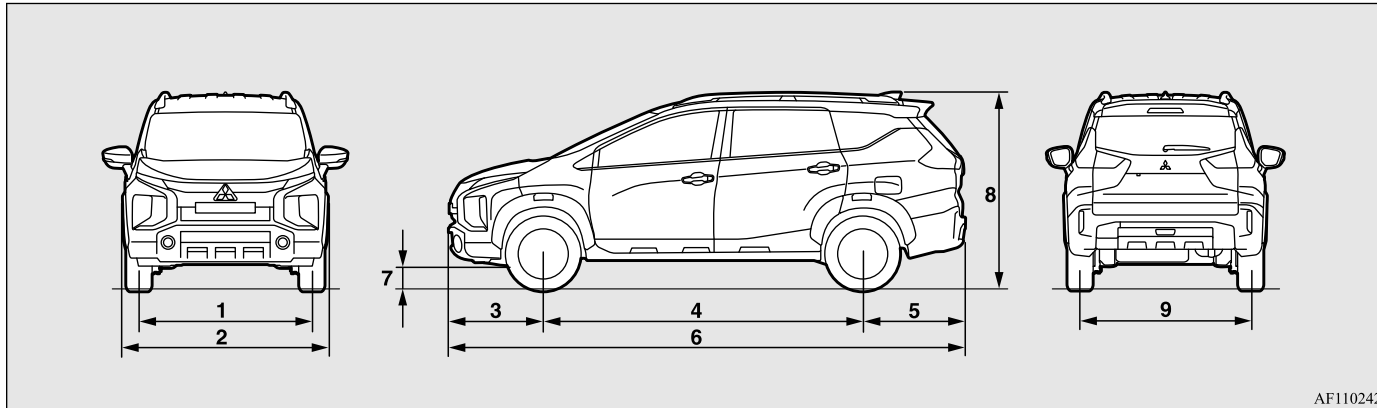

AF1102425

1	Front track	1,520 mm
2	Overall width	1,800 mm
3	Front overhang	825 mm
4	Wheel base	2,775 mm
5	Rear overhang	900 mm
6	Overall length	4,500 mm
7	Ground clearance (unladen)	225 mm
8	Overall height (unladen)	1,750 mm
9	Rear track	1,510 mm
Minimum turning radius	Body	5.5 m
	Wheel	5.2 m

Vehicle performance

NOTE

- The overall width varies depending on whether the vehicle is equipped with wheel lip moldings.
To determine whether your vehicle is equipped with wheel lip moldings, refer to “Exterior - front” on page 1-5.

Vehicle performance

E01100304622

Maximum speed	160 km/h
---------------	----------

Engine specifications

E01100604742

Engine model	4A91
No. of cylinders	4 in line
Total displacement	1,499 cc
Bore	75.0 mm
Stroke	84.8 mm
Camshaft	Double overhead
Mixture preparation	Electronic injection
Maximum output (EEC net)	77 kW/6,000 rpm
Maximum torque (EEC net)	141 N•m/4,000 rpm

Electrical system

E01100804643

Voltage	12 V
Battery	Type (JIS) 34B19L
Alternator capacity	95 A
Spark plug type	NGK LZFR5BI-11

11

Tyres and wheels

E01100905465

Tyre	185/65R15 88H	205/55R16 91V	205/55R17 91V
Wheel	Size	15x5 1/2J	16x6 1/2J 17x6 1/2J
	Offset (Inset)	46 mm	

Capacity

NOTE

- The tyres that can be installed on your vehicle are shown on the driver's door label, refer to "Tyre inflation pressures" on page 10-11. For details, contact an authorised MITSUBISHI MOTORS dealer.

Capacity

E01101308164

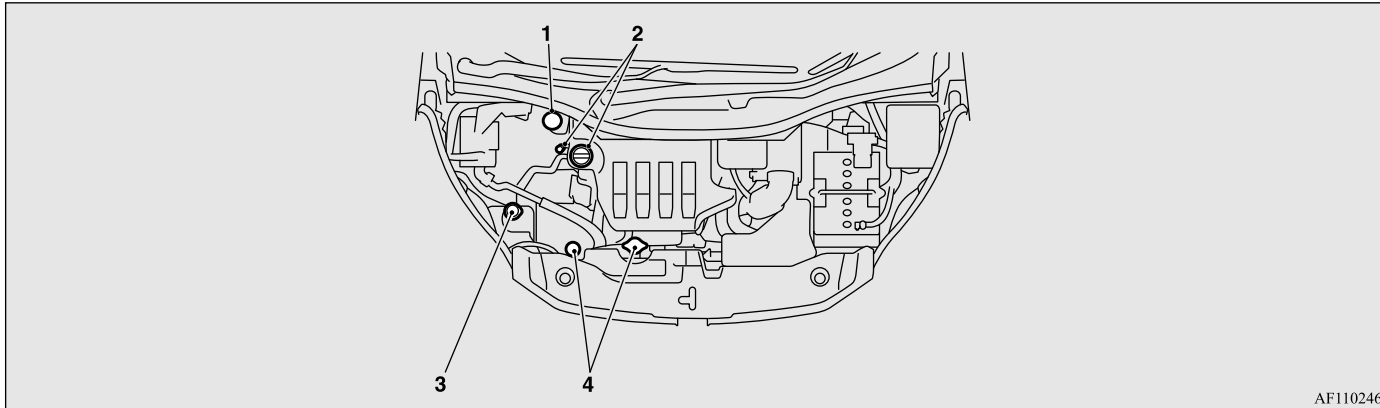

AF1102467

11

No.	Item	Quantity	Lubricants
1	Brake fluid	As required	Brake fluid DOT3 or DOT4
2	Oil pan	3.8 litres	Refer to page 10-4
	Oil filter	0.2 litre	
3	Washer fluid	2.5 litres	—
4	Engine coolant [includes 0.65 litre in the reserve tank]	5.0 litres	MITSUBISHI MOTORS GENUINE SUPER LONG LIFE COOLANT PREMIUM or equivalent*

Capacity

*: Similar high quality ethylene glycol based non-silicate, non-amine, non-nitrate and non-borate coolant with long life hybrid organic acid technology

No.	Item	Quantity	Lubricants
5	Automatic transmission fluid	4.9 litres	MITSUBISHI MOTORS GENUINE ATF-MA1

 **CAUTION**

- Use only the MITSUBISHI MOTORS GENUINE ATF-MA1.
Use of a different fluid could damage the transmission.

No.	Item	Quantity	Lubricants
6	Refrigerant (air conditioning)	595 - 635 g	HFC-134a

 **NOTE**

- Contact an authorised MITSUBISHI MOTORS dealer for details on charging the refrigerant of air conditioning.



ก.ล.น.ค.

เครื่องวิทยุคมนาคมนี้ ได้รับยกเว้น ไม่ต้องได้รับ
ใบอนุญาตให้มี ใช้อุปกรณ์วิทยุคมนาคม
หรือตั้งสถานีวิทยุคมนาคมตามประกาศ กสทช.
เรื่อง เครื่องวิทยุคมนาคม และสถานีวิทยุ
คมนาคมที่ได้รับยกเว้นไม่ต้องได้รับใบอนุญาต
วิทยุคมนาคม ตามพระราชบัญญัติวิทยุ
คมนาคม พ.ศ. 2498



nacc | โทรคมนาคม
กำกับดูแลเพื่อประชาชน
Call Center 1200 (InSW5)

Information for station service

Fuel	Capacity	45 litres
	Recommended fuel	Unleaded petrol octane number 90 RON or higher Refer to the “General information” section for the fuel selection.
Engine oil		Refer to the “Maintenance” section for the selection of engine oil.
Tyre inflation pressure		Refer to the “Maintenance” section for the tyre inflation pressure.